

EVD evolution twin

Driver for 2 electronic expansion valves



ENG User manual

**LEGGI E CONSERVA
QUESTE ISTRUZIONI**
→ **READ AND SAVE
THESE INSTRUCTIONS** ←

  **NO POWER
& SIGNAL
CABLES
TOGETHER**
READ CAREFULLY IN THE TEXT!

Integrated Control Solutions & Energy Savings

WARNINGS



CAREL INDUSTRIES bases the development of its products on decades of experience in HVAC, on the continuous investments in technological innovations to products, procedures and strict quality processes with in-circuit and functional testing on 100% of its products, and on the most innovative production technology available on the market. CAREL INDUSTRIES and its subsidiaries/affiliates nonetheless cannot guarantee that all the aspects of the product and the software included with the product respond to the requirements of the final application, despite the product being developed according to start-of-the-art techniques. The customer (manufacturer, developer or installer of the final equipment) accepts all liability and risk relating to the configuration of the product in order to reach the expected results in relation to the specific final installation and/or equipment.

CAREL INDUSTRIES may, based on specific agreements, acts as a consultant for the successful commissioning of the final unit/application, however in no case does it accept liability for the correct operation of the final equipment/system.

The CAREL INDUSTRIES product is a state-of-the-art product, whose operation is specified in the technical documentation supplied with the product or can be downloaded, even prior to purchase, from the website www.carel.com.

Each CAREL INDUSTRIES product, in relation to its advanced level of technology, requires setup/configuration/programming/commissioning to be able to operate in the best possible way for the specific application. The failure to complete such operations, which are required/indicated in the user manual, may cause the final product to malfunction; CAREL INDUSTRIES accepts no liability in such cases. Only qualified personnel may install or carry out technical service on the product. The customer must only use the product in the manner described in the documentation relating to the product.

In addition to observing any further warnings described in this manual, the following warnings must be heeded for all CAREL INDUSTRIES products:

- prevent the electronic circuits from getting wet. Rain, humidity and all types of liquids or condensate contain corrosive minerals that may damage the electronic circuits. In any case, the product should be used or stored in environments that comply with the temperature and humidity limits specified in the manual;
- do not install the device in particularly hot environments. Too high temperatures may reduce the life of electronic devices, damage them and deform or melt the plastic parts. In any case, the product should be used or stored in environments that comply with the temperature and humidity limits specified in the manual;
- do not attempt to open the device in any way other than described in the manual;
- do not drop, hit or shake the device, as the internal circuits and mechanisms may be irreparably damaged;
- do not use corrosive chemicals, solvents or aggressive detergents to clean the device;
- do not use the product for applications other than those specified in the technical manual.

All of the above suggestions likewise apply to the controllers, serial boards, programming keys or any other accessory in the CAREL INDUSTRIES product portfolio.

CAREL INDUSTRIES adopts a policy of continual development. Consequently, CAREL INDUSTRIES reserves the right to make changes and improvements to any product described in this document without prior warning.

The technical specifications shown in the manual may be changed without prior warning.

The liability of CAREL INDUSTRIES in relation to its products is specified in the CAREL INDUSTRIES general contract conditions, available on the website www.carel.com and/or by specific agreements with customers; specifically, to the extent where allowed by applicable legislation, in no case will CAREL INDUSTRIES, its employees or subsidiaries/affiliates be liable for any lost earnings or sales, losses of data and information, costs of replacement goods or services, damage to things or people, downtime or any direct, indirect, incidental, actual, punitive, exemplary, special or consequential damage of any kind whatsoever, whether contractual, extra-contractual or due to negligence, or any other liabilities deriving from the installation, use or impossibility to use the product, even if CAREL INDUSTRIES or its subsidiaries are warned of the possibility of such damage.

DISPOSAL



INFORMATION FOR USERS ON THE CORRECT HANDLING OF WASTE ELECTRICAL AND ELECTRONIC EQUIPMENT (WEEE)

In reference to European Union directive 2002/96/EC issued on 27 January 2003 and the related national legislation, please note that:

1. WEEE cannot be disposed of as municipal waste and such waste must be collected and disposed of separately;
2. the public or private waste collection systems defined by local legislation must be used. In addition, the equipment can be returned to the distributor at the end of its working life when buying new equipment;
3. the equipment may contain hazardous substances: the improper use or incorrect disposal of such may have negative effects on human health and on the environment;
4. the symbol (crossed-out wheeled bin) shown on the product or on the packaging and on the instruction sheet indicates that the equipment has been introduced onto the market after 13 August 2005 and that it must be disposed of separately;
5. in the event of illegal disposal of electrical and electronic waste, the penalties are specified by local waste disposal legislation.

Warranty on the materials: 2 years (from the date of production, excluding consumables).

Approval: the quality and safety of CAREL INDUSTRIES products are guaranteed by the ISO 9001 certified design and production system.

IMPORTANT: Separate as much as possible the probe and digital input cables from the cables to inductive loads and power cables to avoid possible electromagnetic disturbance.

Never run power cables (including the electrical panel cables) and signal cables in the same conduits

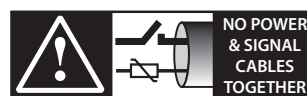

READ CAREFULLY IN THE TEXT!

Contents

| | | | |
|--|-----------|--|-----------|
| 1. INTRODUCTION | 7 | 8. TABLE OF PARAMETERS | 36 |
| 1.1 Models | 7 | 8.1 Table of parameters, driver A..... | 36 |
| 1.2 Main functions and features..... | 7 | 8.2 Table of parameters, driver B..... | 42 |
| 2. INSTALLATION | 9 | 8.3 Unit of measure..... | 47 |
| 2.1 DIN rail assembly and dimensions..... | 9 | 8.4 Variables accessible via serial connection – driver A..... | 48 |
| 2.2 Description of the terminals..... | 9 | 8.5 Variables accessible via serial connection – driver B..... | 49 |
| 2.3 Connection diagram - superheat control | 9 | 8.6 Variables used based on the type of control..... | 50 |
| 2.4 Installation..... | 10 | 9. ALARMS | 51 |
| 2.5 Valve operation in parallel and complementary mode..... | 10 | 9.1 Alarms..... | 51 |
| 2.6 Shared pressure probe..... | 11 | 9.2 Alarm relay configuration..... | 52 |
| 2.7 Connecting the USB-tLAN converter..... | 11 | 9.3 Probe alarms..... | 53 |
| 2.8 Connecting the module EVBAT00400..... | 12 | 9.4 Control alarms | 53 |
| 2.9 Connecting the USB/RS485 converter..... | 12 | 9.5 EEV motor alarm..... | 54 |
| 2.10 Upload, Download and Reset parameters (display) | 12 | 9.6 LAN error alarm..... | 54 |
| 2.11 Display electrical connections (display) | 12 | 10. TROUBLESHOOTING | 55 |
| 2.12 General connection diagram..... | 13 | 11. TECHNICAL SPECIFICATIONS | 57 |
| 3. USER INTERFACE | 14 | 12. APPENDIX 1: VPM (VISUAL PARAMETER MANAGER) | 58 |
| 3.1 Assembling the display board (accessory)..... | 14 | 12.1 Installation | 58 |
| 3.2 Display and keypad..... | 14 | 12.2 Programming (VPM)..... | 58 |
| 3.3 Switching between drivers (display) | 15 | 12.3 Copying the setup | 59 |
| 3.4 Display mode (display)..... | 15 | 12.4 Setting the default parameters..... | 59 |
| 3.5 Programming mode (display)..... | 15 | 12.5 Updating the controller and display firmware..... | 59 |
| 4. COMMISSIONING | 16 | 13. APPENDIX 2: EVD EVOLUTION SINGLE | 60 |
| 4.1 Commissioning..... | 16 | 13.1 Enable single mode on twin | 60 |
| 4.2 Setting the pLAN network address..... | 16 | 13.2 User interface – LED card | 60 |
| 4.3 Guided commissioning procedure (display)..... | 17 | 13.3 Connection diagram - superheat control | 60 |
| 4.4 Checks after commissioning | 19 | 13.4 Parameters enabled/disabled for control..... | 60 |
| 4.5 Other functions..... | 19 | 13.5 Programming with the display | 61 |
| 5. CONTROL | 20 | 13.6 Auxiliary refrigerant..... | 61 |
| 5.1 Main control..... | 20 | 13.7 S3 e S4 inputs..... | 61 |
| 5.2 Superheat control | 20 | 13.8 Main control – additional functions | 61 |
| 5.3 Adaptive control and autotuning | 22 | 13.9 Auxiliary control | 62 |
| 5.4 Control with Emerson Climate Digital Scroll™ compressor. | 23 | 13.10 Variables used based on the type of control | 65 |
| 5.5 Special control..... | 23 | | |
| 5.6 Programmable control..... | 26 | | |
| 5.7 Control with refrigerant level sensor..... | 28 | | |
| 6. FUNCTIONS | 29 | | |
| 6.1 Power supply mode..... | 29 | | |
| 6.2 Battery charge delay..... | 29 | | |
| 6.3 Network connection | 29 | | |
| 6.4 Inputs and outputs..... | 29 | | |
| 6.5 Control status | 31 | | |
| 6.6 Special control status..... | 32 | | |
| 7. PROTECTORS | 34 | | |
| 7.1 Protectors | 34 | | |

1. INTRODUCTION

EVD evolution twin is a controller featuring two drivers for double pole stepper motors that independently manages two electronic expansion valves. It is designed for DIN rail assembly and is fitted with plug-in screw terminals. Each driver controls refrigerant superheat and optimises the efficiency of the refrigerant circuit, guaranteeing maximum flexibility, being compatible with various types of refrigerants and valves, in applications with chillers, air-conditioners and refrigerators, the latter including subcritical and transcritical CO₂ systems. It features low superheat (LowSH), high evaporation pressure (MOP), and low evaporation pressure (LOP) protection, and can manage, as an alternative to superheat control, special functions such as the hot gas bypass, evaporator pressure regulation (EPR) and control of the valve downstream of the gas cooler in transcritical CO₂ circuits. The controller can drive an electronic expansion valve in a refrigerant circuit with Digital Scroll compressor, if integrated with a specific CAREL controller via LAN. In addition, it features adaptive control that can evaluate the effectiveness of superheat control and if necessary activate one or more tuning procedures. As regards network connectivity, the controller can be connected to either of the following:

- a pCO programmable controller to manage the controller via pLAN, tLAN and RS485/Modbus*;
- a PlantVisorPRO supervisor via RS485/Modbus*. In this case, On/Off control is performed via digital input 1 for driver A and via digital input 2 for driver B, if suitably configured. As well as regulation start/stop, digital inputs 1 and 2 can be configured for the following:
 - valve regulation optimization after defrost;
 - valve forced open (at 100%);
 - regulation backup;
 - regulation security.

The last two possibilities refer to the behaviour of the driver when there is no communication over the pLAN or tLAN, RS485/Modbus* network (see chap. 6).

Another possibility involves operation as a simple positioner with 4 to 20 mA or 0 to 10 Vdc analogue input signal for driver A (inputs S1 and S2 respectively) and with 4 to 20 mA signal for driver B (input S3). EVD evolution twin comes with a LED board to indicate the operating status, or a graphic display (accessory) that can be used to perform installation, following a guided commissioning procedure involving setting just 4 parameters for each driver: refrigerant, valve, pressure sensor, type of main control (chiller, showcase, etc.). The procedure can also be used to check that the sensor and valve motor wiring is correct. Once installation is complete, the display can be removed, as it is not necessary for the operation of the controller, or alternatively kept in place to display the significant system variables, any alarms and when necessary set the control parameters. The controller can also be setup using a computer via the service serial port. In this case, the VPM program (Visual Parameter Manager) needs to be installed, downloadable from <http://ksa.carel.com>, and the USB-tLAN converter EVDENV00E0 connected. Only on RS485/Modbus* models can installation be managed as described above by computer, using the serial port (see paragraph 2.9) in place of the service serial port. The "universal" models can drive all types of valves, while the "CAREL" models only drive CAREL valves.

1.1 Models

| Code | Description |
|------------|---|
| EVD0000T00 | EVD evolution twin universal (tLAN) |
| EVD0000T01 | EVD evolution twin universal (tLAN) pack of 10 pcs. (*) |
| EVD0000T10 | EVD evolution twin universal (pLAN) |
| EVD0000T11 | EVD evolution twin universal (pLAN) pack of 10 pcs. (*) |
| EVD0000T20 | EVD evolution twin universal (RS485/Modbus*) |
| EVD0000T21 | EVD evolution twin universal (RS485/Modbus*) pack of 10 pcs. (*) |
| EVD0000T30 | EVD evolution twin for Carel valves (tLAN) |
| EVD0000T31 | EVD evolution twin for Carel valves (tLAN) pack of 10 pcs. (*) |
| EVD0000T40 | EVD evolution twin for Carel valves (pLAN) |
| EVD0000T41 | EVD evolution twin for Carel valves (pLAN) pack of 10 pcs. (*) |
| EVD0000T50 | EVD evolution twin for Carel valves (RS485/Modbus*) |
| EVD0000T51 | EVD evolution twin for Carel valves (RS485/Modbus*) pack of 10 pcs. (*) |
| EVDCON0021 | EVD Evolution, connector kit (10pcs) for multi-pack(*) |

Tab. 1.a

(*) The codes with multiple packages are sold without connectors, available separately in code EVDCON0021.

1.2 Main functions and features

In summary:

- electrical connections by plug-in screw terminals;
- serial card incorporated in the controller, based on the model (tLAN, pLAN, RS485/Modbus*);
- compatibility with various types of valves ("universal" models only) and refrigerants;
- activation/deactivation of control via digital input 1 for driver A and digital input 2 for driver B, if suitably configured, or remote control via LAN, from pCO programmable controller;
- superheat control with protection functions for low superheat LowSH, MOP, LOP;
- adaptive superheat control;
- function to optimise superheat control for air-conditioning units fitted with Emerson Climate Technologies Digital Scroll compressor. In this case, EVD Evolution twin must be connected to a CAREL pCO series controllers running an application program that can manage units with Digital Scroll compressors. This function is only available on the controllers for CAREL valves;
- configuration and programming by display (accessory), by computer using the VPM program or by PlantVisor/PlantVisorPro supervisor and pCO programmable controller;
- commissioning simplified by display with guided procedure for setting the parameters and checking the electrical connections;
- multi-language graphic display, with "help" function on various parameters;
- management of different units of measure (metric/imperial);
- parameters protected by password, accessible at a service (installer) and manufacturer level;
- copy the configuration parameters from one EVD evolution twin controller to another using the removable display;
- ratiometric or electronic 4 to 20 mA pressure transducer, the latter can be shared between up to 5 drivers (maximum 2 EVD evolution twins + 1 EVD Evolution), useful for multiplexed applications;
- 4 to 20 mA or 0 to 10 Vdc input to use the controller as a positioner controlled by an external signal;
- management of power failures with valve closing (only for controllers with 24 Vac power supply connected to EVD0000UC0 accessory);
- advanced alarm management.

For software versions higher than 4.0, the following new functions have been introduced:

- 24 Vac or 24 Vdc power supply, in the latter case without valve closing in the event of power failures;
- pre-position time settable by parameter;
- use of digital to start/stop control when there is no communication with the pCO programmable controller.

Starting from software revision 5.0 and higher, new functions have been introduced:

- management of new refrigerants;
- valve position in standby settable by parameter;
- operation as EVD Evolution with single driver: the driver controls one expansion valve only (valve A), however it acquires new functions available using probes S3 and S4:
 1. electronic valve control in a refrigerant circuit with BLDC compressor, controlled by CAREL Power+ speed driver (with inverter);
 2. superheat control with two temperature probes;
 3. auxiliary control functions:
 - backup probes S3 and S4;
 - subcooling measurement;
 - high condensing temperature protection (HiTcond);
 - modulating thermostat;
 - subcooling measurement;
 - reverse high condensing temperature protection;
 - possibility to manage CO₂ (R744) cascade systems, setting the refrigerant for the primary and secondary circuit.

New functions have been introduced with software revision 5.4 and higher:

- programmable control, both superheat and special, and programmable positioner: these functions exploit CAREL's technology and know-how in terms of control logic;
- custom refrigerant selection;
- control with level sensor for flooded evaporator;
- control with level sensor for flooded condenser.

From the software revision following the 7.2-7.3 new features have been introduced, including:

- battery charge delay;
- external signal 0 ... 5 V (for programmable positioner).

Series of accessories for EVD evolution twin

Display (code EVDIS00**0)

Easily applicable and removable at any time from the front panel of the controller, during normal operation displays all the significant variables for system A and B, the status of the relay outputs and recognises the activation of the protection functions and alarms. During commissioning, it guides the installer in setting the parameters required to start the installations and, once completed, can copy the parameters to other EVD evolution twin controllers. The models differ in the first settable language, the second language for all models is English. EVDIS00**0 can be used to configure and monitor all the control parameters for both drivers, accessible via password at a service (installer) and manufacturer level.



Fig. 1.a

USB/tLAN converter (code EVDCNV00E0)

The USB-tLAN converter is connected, once the LED board cover has been removed, to the service serial port underneath. Fitted with cables and connectors, it can connect EVD evolution twin directly to a computer, which, using the VPM program, can configure and program the controller. VPM can also be used to update the controller and display firmware. See the appendix.



Fig. 1.b

USB/RS485 converter (code CVSTDUMORO)

The converter is used to connect the configuration computer and the EVD evolution twin controllers, for RS485/Modbus® models only.



Fig. 1.c

Ultracap module (P/N EVD0000UC0)

The module, mounted on DIN rail, guarantees temporary power to the driver in the event of power failures, for enough time to immediately close the connected electronic valves (one or two). It avoids the need to install a solenoid valve. The module is made using Ultracap storage capacitors, which ensure reliability in terms of much longer component life than a module made with lead batteries. In just 4 minutes the module is ready to power two Carel valves again (or 5 minutes for pairs or other brand valves).



Fig. 1.d

Valve cable E2VCABS*00 (IP67)

Shielded cable with built-in connector for connection to the valve motor. The connector code E2VCON0000 (IP65) can also be purchased on its own, to be wired.



Fig. 1.e

Float level sensor (P/N LSR0013000)

The level sensor measures the quantity of refrigerant in the heat exchanger. This is used when controlling the valve based on the liquid level in the flooded evaporator or condenser. Available with threaded or flanged connector.



Fig. 1.f

2. INSTALLATION

2.1 DIN rail assembly and dimensions

EVD evolution twin is supplied with screen-printed connectors to simplify wiring.

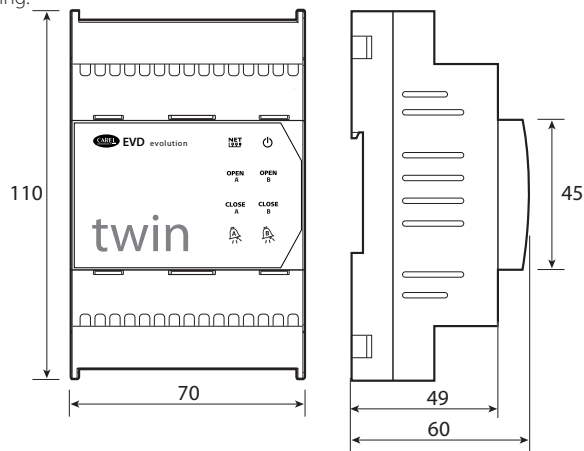

Fig. 2.a

2.2 Description of the terminals

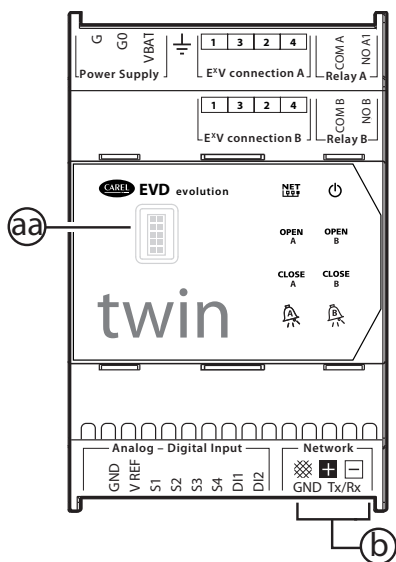

Fig. 2.b

| Terminal | Description |
|---------------------------|---|
| G, G0 | Power supply |
| VBAT | Emergency power supply |
| | Functional earth |
| 1,3,2,4: ExV connection A | Stepper motor power supply driver A |
| COM A, NO A | Alarm relay driver A |
| 1,3,2,4: ExV connection B | Stepper motor power supply driver B |
| COM B, NO B | Alarm relay driver B |
| GND | Signal ground |
| VREF | Power supply to active probes |
| S1 | Probe 1 (pressure) or 4 to 20mA external signal |
| S2 | Probe 2 (temperature) or 0 to 10V external signal |
| S3 | Probe 3 (pressure) or 4 to 20mA external signal |
| S4 | Probe 4 (temperature) |
| DI1 | Digital input 1 |
| DI2 | Digital input 2 |
| | Terminal for tLAN, pLAN, RS485/ModBus® connection |
| | Terminal for tLAN, pLAN, RS485/ModBus® connection |
| | Terminal for pLAN, RS485/ModBus® connection |
| aa | service serial port (remove the cover for access) |
| b | serial port |

Tab. 2.a

2.3 Connection diagram - superheat control

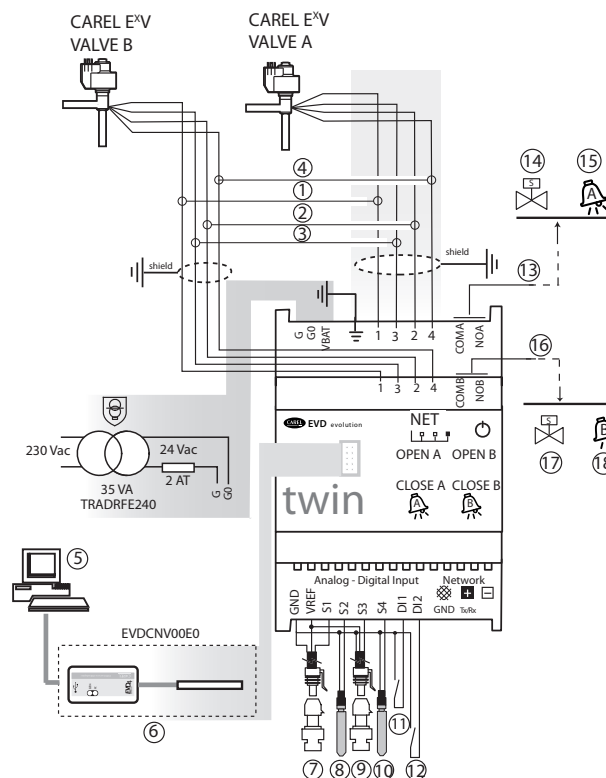

Fig. 2.c

Key:

| | |
|----|---|
| 1 | green |
| 2 | yellow |
| 3 | brown |
| 4 | white |
| 5 | personal computer for configuration |
| 6 | USB/tLAN converter |
| 7 | ratiometric pressure transducer–evaporation pressure driver A |
| 8 | NTC – suction temperature driver A |
| 9 | ratiometric pressure transducer–evaporation pressure driver B |
| 10 | NTC – suction temperature driver B |
| 11 | digital input 1 configured to enable control driver A |
| 12 | digital input 2 configured to enable control driver B |
| 13 | voltage-free contact driver A (up to 230 V) |
| 14 | solenoid valve A |
| 15 | alarm signal A |
| 16 | voltage-free contact driver B (up to 230 V) |
| 17 | solenoid valve B |
| 18 | alarm signal B |

Note:

- connect the valve cable shield to the electrical panel earth;
- the use of driver A for superheat control requires the use of the evaporation pressure probe S1 and the suction temperature probe S2, which will be fitted after the evaporator, and digital input 1 to enable control. As an alternative to digital input 1, control can be enabled via remote signal (tLAN, pLAN, RS485/ModBus®). For the positioning of the probes relating to other applications, see the chapter on “Control”;
- the use of driver B for superheat control requires the use of the evaporation pressure probe S3 and the suction temperature probe S4, which will be fitted after the evaporator, and digital input 2 to enable control. As an alternative to digital input 2, control can be enabled via remote signal (tLAN, pLAN, RS485/ModBus®). For the positioning of the probes relating to other applications, see the chapter on “Control”;
- inputs S1, S2, S3 & S4 are programmable and the connection to the terminals depends on the setting of the parameters. See the chapters on “Commissioning” and “Functions”;

- pressure probes S1 & S2 in the diagram are ratiometric. See the general connection diagram for the other electronic probes, 4 to 20 mA or combined;
- the pressure probes S1 and S3 must be of the same type.

2.4 Installation

For installation proceed as follows, with reference to the wiring diagrams:

1. connect the probes: the probes can be installed a maximum distance of 10 metres away from the driver, or a maximum of 30 metres as long as shielded cables with a minimum cross-section of 1 mm² are used;
2. connect any digital inputs, maximum length 30 m;
3. connect the power cable to the valve motors: use 4-wire shielded cable AWG 22 Lmax=10 m or AWG 14 Lmax=50m; failure to connect the valve motors after connecting the controller will generate the "EEV motor error" alarm: see paragraph 9.5;
4. carefully evaluate the maximum capacity of the relay outputs specified in the chapter "Technical specifications";
5. if necessary, use a class 2 safety transformer with suitable short-circuit and overload protection. For the power ratings of the transformer see the general connection diagram and the technical specifications;
6. the connection cables must have a minimum cross-section of 0.5 mm²;
7. power up the controller: for 24 Vdc power supply the controller will close the valves;

Important: for 24 Vdc power supply, set "Power supply mode" parameter=1 to start control. See par. 6.1

Drivers in a serial network

Case 1: multiple controllers connected in a network powered by the same transformer. Typical application for a series of controllers inside the same electrical panel

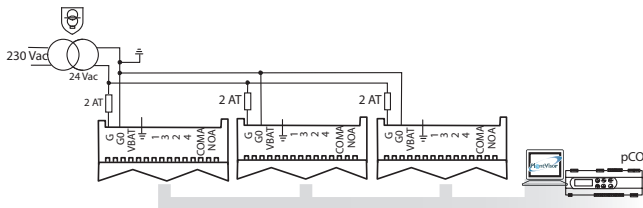

Fig. 2.d

Case 2: multiple controllers connected in a network powered by different transformers (G0 not connected to earth). Typical application for a series of controllers in different electrical panels.

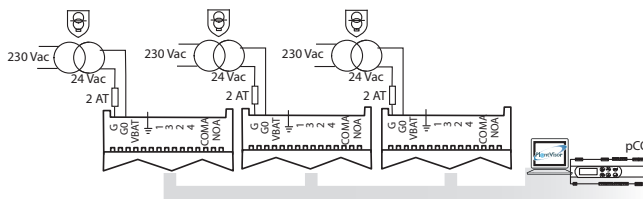

Fig. 2.e

Case 3: multiple controllers connected in a network powered by different transformers with just one earth point. Typical application for a series of controllers in different electrical panels.

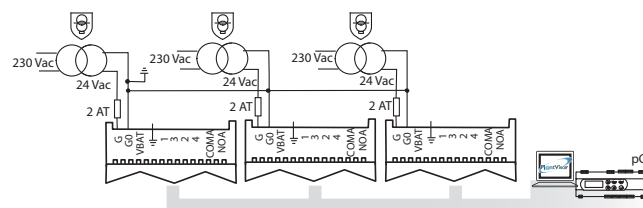

Fig. 2.f

Important: earthing G0 and G on a driver connected to a serial network will cause permanent damage to the driver.

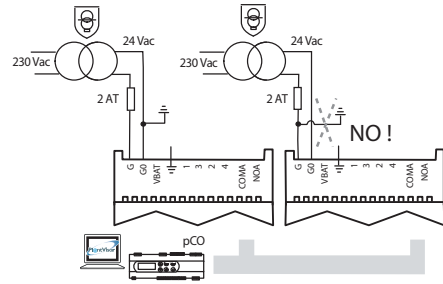

Fig. 2.g

Installation environment

Important: avoid installing the controller in environments with the following characteristics:

- relative humidity greater than the 90% or condensing;
- strong vibrations or knocks;
- exposure to continuous water sprays;
- exposure to aggressive and polluting atmospheres (e.g.: sulphur and ammonia fumes, saline mist, smoke) to avoid corrosion and/or oxidation;
- strong magnetic and/or radio frequency interference (avoid installing the appliances near transmitting antennae);
- exposure of the controller to direct sunlight and to the elements in general.

Important: When connecting the controller, the following warnings must be observed:

- if the controller is not used as specified in this user manual, the protection indicated is not guaranteed;
- incorrect connection to the power supply may seriously damage the controller;
- use cable ends suitable for the corresponding terminals. Loosen each screw and insert the cable ends, then tighten the screws and lightly tug the cables to check correct tightness;
- separate as much as possible (at least 3 cm) the probe and digital input cables from the power cables to the loads so as to avoid possible electromagnetic disturbance. Never lay power cables and probe cables in the same conduits (including those in the electrical panels);
- install the shielded valve motor cables in the probe conduits: use shielded valve motor cables to avoid electromagnetic disturbance to the probe cables;
- avoid installing the probe cables in the immediate vicinity of power devices (contactors, circuit breakers, etc.). Reduce the path of the probe cables as much as possible and avoid enclosing power devices;
- avoid powering the controller directly from the main power supply in the panel if this supplies different devices, such as contactors, solenoid valves, etc., which will require a separate transformer.
- * EVD EVO is a control to be incorporated in the end equipment, do not use for flush mount
- * DIN VDE 0100: Protective separation between SELV circuit and other circuits must be guaranteed. The requirements according to DIN VDE 0100 must be fulfilled. To prevent infringement of the protective separation (between SELV circuit to other circuits) an additional fixing has to be provided near to the terminals. This additional fixing shall clamp the insulation and not the conductor".

2.5 Valve operation in parallel and complementary mode

EVD evolution twin can control two CAREL valves connected together (see paragraph 4.2), in parallel mode, with identical behaviour, or in complementary mode, whereby if one valve opens, the other closes by the same percentage. To achieve such behaviour, simply set the "valve" parameter ("Two EXV connected together") and connect the valve motor power supply wires to the same connector. In the example shown below, for operation of valve B_1 in complementary mode simply swap the connection of wires 1 and 3.

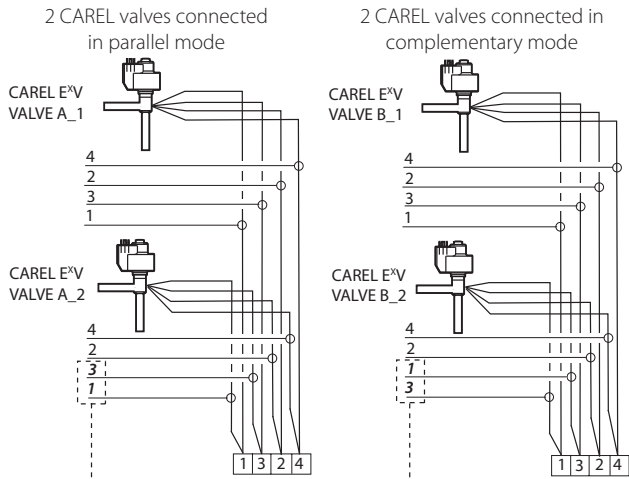

Fig. 2.h

Important: in the case of installations with four valves, the EVD0000UC0 module cannot guarantee all four will close in the event of power failures.

Note: operation in parallel and complementary mode can only be used for CAREL valves, within the limits shown in the table below, where OK means that the valve can be used with all refrigerants at the rated operating pressure.

| | Model of CAREL valve | | | | | |
|----------------------------|----------------------|---|--|-----|-----|-----|
| | E2V | E3V | E4V | E5V | E6V | E7V |
| Two EXV connected together | OK | E3V45, MOPD=35bar E3V55, MOPD=26bar E3V65, MOPD=20bar | E4V85, MOPD=22bar E4V95, MOPD=15bar | NO | NO | NO |

Tab. 2.b

Nota: MOPD = Maximum Operating-Pressure Differential

2.6 Shared pressure probe

Only 4 to 20 mA pressure probes (not ratiometric) can be shared. The probe can be shared by a maximum of 5 drivers. For multiplexed systems where twin1, twin2 and twin3 controllers share the same pressure probe, choose the normal option for driver A on the twin 1 controller and the "remote" option for the other drivers. Driver B on the twin3 controller must use another pressure probe, P2.

Example

| | twin1 | twin2 | twin3 |
|---------------------|------------------------|------------------------|------------------------|
| Probe S1 (driver A) | -0.5 to 7 barg (P1) | remote, -0.5 to 7 barg | remote, -0.5 to 7 barg |
| Probe S3 (driver B) | remote, -0.5 to 7 barg | remote, -0.5 to 7 barg | -0.5 to 7 barg (P2) |

Tab. 2.c

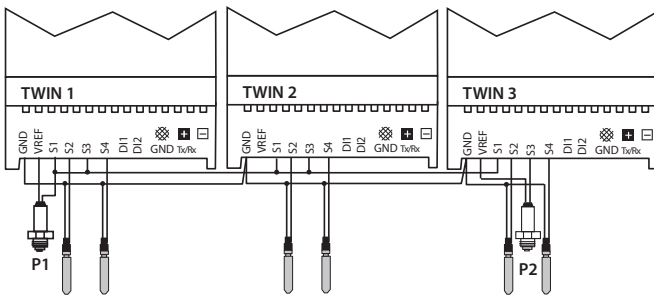

Fig. 2.i

Key:

| | |
|----|-----------------------|
| P1 | shared pressure probe |
| P2 | pressure probe |

2.7 Connecting the USB-tLAN converter

Procedure:

- remove the LED board cover by pressing on the fastening points;
- plug the adapter into the service serial port;
- connect the adapter to the converter and then this in turn to the computer
- power up the controller

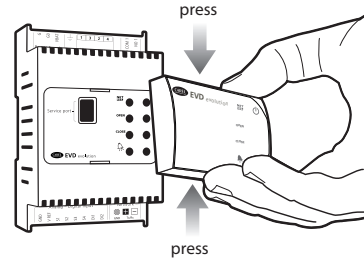

Fig. 2.j

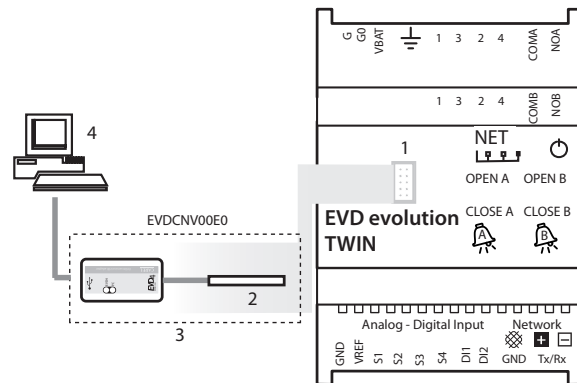

Fig. 2.k

Key:

| | |
|---|---------------------|
| 1 | service serial port |
| 2 | adapter |
| 3 | USB/tLAN converter |
| 4 | personal computer |

Note: when using the service serial port connection, the VPM program can be used to configure the controller and update the controller and display firmware, downloadable from <http://ksa.carel.com>. See the appendix.

2.8 Connecting the module EVBAT00400

The EVBAT00400 module can close the valve in the event of power failures. Digital input 1/2 can be configured to detect the "Discharged battery" alarm.

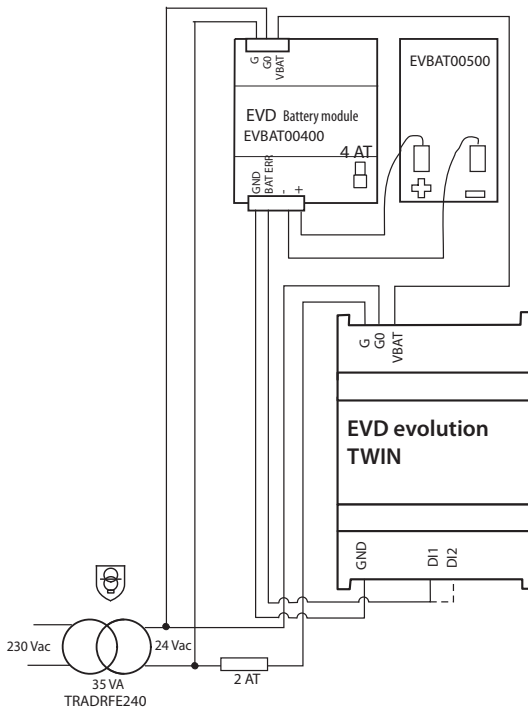

Fig. 2.l

Note: set the "Battery charge delay" parameter, depending on the application. See the chapter "Functions".

2.9 Connecting the USB/RS485 converter

Only on EVD evolution twin RS485/Modbus® models can the configuration computer be connected using the USB/RS485 converter and the serial port, according to the following diagram:

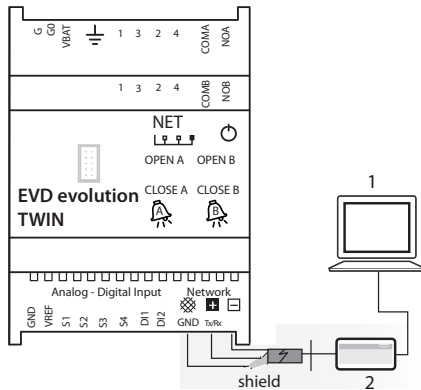

Fig. 2.m

Key:

| | |
|---|-------------------------------------|
| 1 | personal computer for configuration |
| 2 | USB/RS485 converter |

Note:

- the serial port can be used for configuration with the VPM program and for updating the controller firmware, downloadable from <http://ksa.carel.com>;
- to save time, up to 8 controllers EVD evolution twin can be connected to the computer, updating the firmware at the same time (each controller must have a different network address).

2.10 Upload, Download and Reset parameters (display)

Procedure:

- press the Help and ENTER buttons together for 5 seconds;
 - a multiple choice menu will be displayed, use UP/DOWN to select the required procedure;
 - confirm by pressing ENTER;
 - the display will prompt for confirmation, press ENTER;
 - at the end a message will be shown to notify the operation if the operation was successful.
- UPLOAD: the display saves all the values of the parameters on the source controller;
 - DOWNLOAD: the display copies all the values of the parameters to the target controller;
 - RESET: all the parameters on the controller are restored to the default values.
 - See the table of parameters in chapter 8.



Fig. 2.n

Important:

- the procedure must be carried out with controller/controllers powered;
- DO NOT remove the display from the controller during the UPLOAD, DOWNLOAD, RESET procedure;
- the parameters cannot be downloaded if the source controller and the target controller have incompatible firmware;
- the parameters cannot be copied from driver A to driver B.

2.11 Display electrical connections (display)

To display the probe and valve electrical connections for drivers A and B, enter display mode. See paragraph 3.4

2.12 General connection diagram

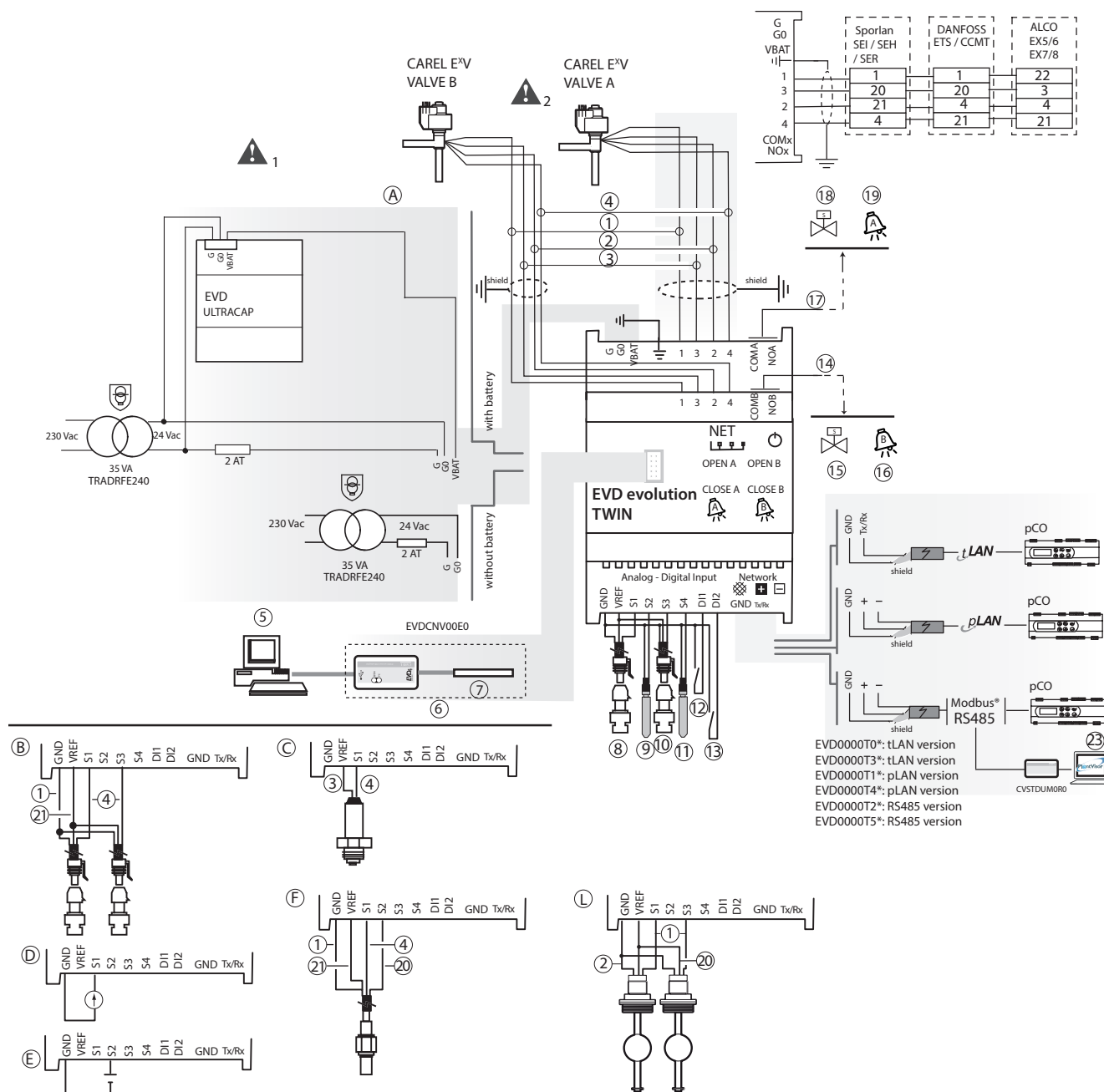

3. USER INTERFACE

The user interface consists of 8 LEDs that display the operating status, as shown in the table:

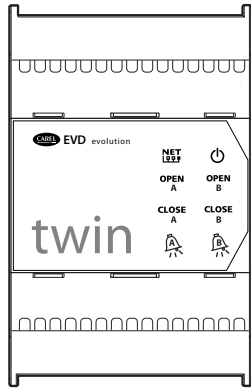

Fig. 3.a

Key:

| LED | On | Off | Flashing |
|--------------------|-------------------------|----------------|---|
| NET | Connection active | No connection | Communication error |
| OPEN A/B | Opening valve A/B | - | Driver A/B disabled (*) |
| CLOSE A/B | Closing valve A/B | - | Driver A/B disabled (*) |
| OPEN B/ CLOSE B | - | - | EVD Evolution TWIN operating as single driver |
| | Active alarm driver A/B | - | - |
| | Controller powered | Controller off | Wrong power supply (see chap. on Alarms) |

Tab. 3.a

(*) Awaiting completion of the initial configuration

3.1 Assembling the display board (accessory)

The display board, once installed, is used to perform all the configuration and programming operations on the two drivers. It displays the operating status, the significant values for the type of control that the drivers are performing (e.g. superheat control), the alarms, the status of the digital inputs and the relay outputs. Finally, it can save the configuration parameters for one controller and transfer them to a second controller (see the procedure for uploading and downloading the parameters).

For installation:

- remove the cover, pressing on the fastening points;
- fit the display board, as shown;
- the display will come on, and if the controller is being commissioned, the guided configuration procedure will start.

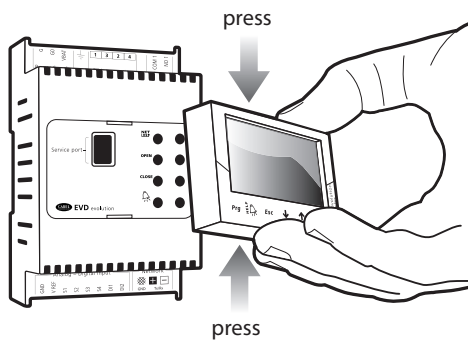

Fig. 3.b

Important: the controller is not activated if the configuration procedure has not been completed. The front panel now holds the display and the keypad, made up of 6 buttons, that, pressed alone or in combination, are used to perform all the configuration and programming operations on the controller.

3.2 Display and keypad

The graphic display shows two variables for each driver (A, B), the control status of the driver, activation of the protectors, any alarms and the status of the relay output.

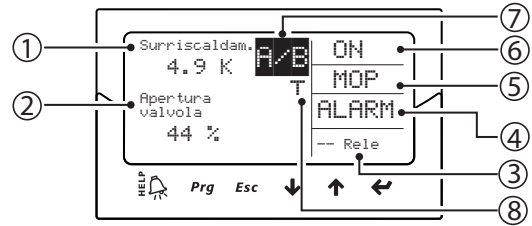

Fig. 3.c

Key:

| | |
|---|--|
| 1 | variable 1 on the display (driver A/B) |
| 2 | variable 2 on the display (driver A/B) |
| 3 | relay status (driver A/B) |
| 4 | alarm (press "HELP") |
| 5 | protector activated |
| 6 | control status |
| 7 | current display: driver A/driver B |
| 8 | adaptive control in progress |

Messages on the display

| | Control status | | Active protection |
|-------|---|---------|------------------------------|
| ON | Operation | LowSH | Low superheat |
| OFF | Standby | LOP | Low evaporation temperature |
| POS | Positioning | MOP | High evaporation temperature |
| WAIT | Wait | HiTcond | High condensing temperature |
| CLOSE | Closing | | |
| INIT | Valve motor error recognition procedure (*) | | |
| TUN | Tuning in progress | | |

Tab. 3.b

(*) The valve motor error recognition procedure can be disabled. See paragraph 9.5.

(**) Only if EVD Evolution TWIN is operating as a single driver or programmable superheat control is enabled.

Keypad

| Button | Function |
|--------|--|
| Prg | • opens the screen for entering the password to access programming mode. |
| | • if in alarm status, displays the alarm queue; • in the "Manufacturer" level, when scrolling the parameters, shows the explanation screens (Help); • pressed together with ENTER, switches the display from one driver to the other |
| Esc | • exits the Programming (Service/Manufacturer) and Display modes; • after setting a parameter, exits without saving the changes. |
| | • navigates the screens on the display; • increases/decreases the value. |
| ENTER | • switches from display to parameter programming mode; • confirms the value and returns to the list of parameters; • pressed together with HELP, switches the display from one driver to the other. |

Tab. 3.c

Note: the variables displayed as standard can be selected by configuring the parameters "Variable 1 on display" and "Variable 2 on display" for each driver. See the list of parameters.

3.3 Switching between drivers (display)

Procedure:

press the Help and Enter buttons together. Switching when programming the parameters displays the parameters for driver A and driver B on the same screen.

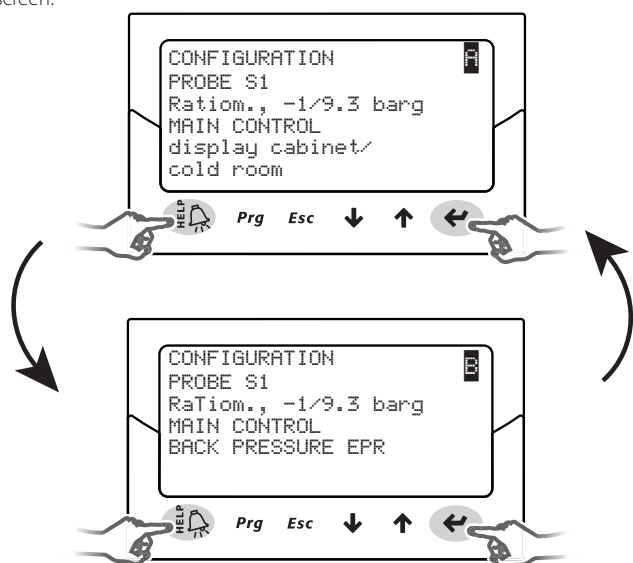

Fig. 3.d

Important: the probe S1 parameter is common to both drivers, while the main control parameter must be set for each driver. See the table of parameters.

3.4 Display mode (display)

Display mode is used to display the useful variables showing the operation of the system.

The variables displayed depend on the type of control selected.

1. Press Esc one or more times to switch to the standard display;
2. Select driver A or B to display the corresponding variables (see paragraph 3.3);
3. press UP/DOWN: the display shows a graph of the superheat, the percentage of valve opening, the evaporation pressure and temperature and the suction temperature variables;
4. press UP/DOWN: the variables are shown on the display followed by the screens with the probe and valve motor electrical connections;
5. press Esc to exit display mode.

For the complete list of variables used according to the type of control see paragraph "Variables used based on the type of control".

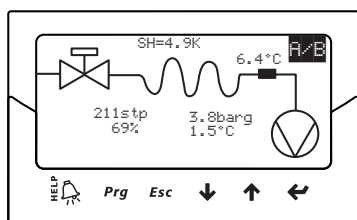

Fig. 3.e

3.5 Programming mode (display)

The parameters can be modified using the front keypad. Access differs according to the user level: Service (Installer) and Manufacturer parameters.

Modifying the Service parameters

The Service parameters, as well as the parameters for commissioning the controller, also include those for the configuration of the inputs, the relay output, the superheat set point or the type of control in general, and the protection thresholds. See the table of parameters.

Procedure:

1. press Esc one or more times to switch to the standard display and select driver A or B to set the corresponding parameters (see paragraph 3.3);
2. press Prg: the display shows a screen with the PASSWORD request;

3. press ENTER and enter the **password for the Service level: 22**, starting from the right-most figure and confirming each figure with ENTER;
4. if the value entered is correct, the first modifiable parameter is displayed, network address;
5. press UP/DOWN to select the parameter to be set;
6. press ENTER to move to the value of the parameter;
7. press UP/DOWN to modify the value;
8. press ENTER to save the new value of the parameter;
9. repeat steps 5, 6, 7, 8 to modify the other parameters;
10. press Esc to exit the procedure for modifying the Service parameters.

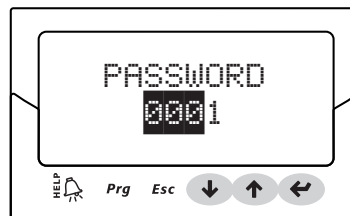

Fig. 3.f

Note:

- if when setting a parameter the value entered is out-of-range, this is not accepted and the parameter soon after returns to the previous value;
- if no button is pressed, after 5 min the display automatically returns to the standard mode.
- to set a negative value use ENTER to move to the left-most digit and press UP/DOWN.

Modifying the Manufacturer parameters

The Manufacturer level is used to configure all the controller parameters, and consequently, in addition to the Service parameters, the parameters relating to alarm management, the probes and the configuration of the valve. See the table of parameters.

Procedure:

1. press Esc one or more times to switch to the standard display;
2. Select driver A or B to set the corresponding parameters (see paragraph 3.3);
3. press Prg: the display shows a screen with the PASSWORD request;
4. press ENTER and enter the **password for the Manufacturer level: 66**, starting from the right-most figure and confirming each figure with ENTER;
5. if the value entered is correct, the list of parameter categories is shown:
 - Configuration
 - Probes
 - Control
 - Special
 - Alarm configuration
 - Valve
6. press the UP/DOWN buttons to select the category and ENTER to access the first parameter in the category;
7. press UP/DOWN to select the parameter to be set and ENTER to move to the value of the parameter;
8. press UP/DOWN to modify the value;
9. press ENTER to save the new value of the parameter;
10. repeat steps 7, 8, 9 to modify the other parameters;
11. press Esc to exit the procedure for modifying the Manufacturer parameters



Fig. 3.g

Note:

- all the controller parameters can be modified by entering the Manufacturer level;
- if when setting a parameter the value entered is out-of-range, this is not accepted and the parameter soon after returns to the previous value;
- if no button is pressed, after 5 min the display automatically returns to the standard mode.

4. COMMISSIONING

! Important: if the refrigerant is not available among the refrigerant parameter options, contact CAREL service to:

- confirm that the system: pCO controller + CAREL electronic expansion valve is compatible with the desired refrigerant (custom);
- identify the values that define the custom refrigerant: "Dew a...f high/low" and "Bubble a...f high/low". See the parameter table.

4.1 Commissioning

Once the electrical connections have been completed (see the chapter on installation) and the power supply has been connected, the operations required for commissioning the controller depend on the type of interface used, however essentially involve setting just 4 parameters: refrigerant, valve, type of pressure probe (S1 for driver A and S3 for driver B) and type of main control. The network address for EVD evolution twin is single.

Types of interfaces:

- DISPLAY:** after having correctly configured the setup parameters, confirmation will be requested. Only after confirmation will the controller be enabled for operation, the main screen will be shown on the display and control will be able to commence when requested by the pCO controller via LAN or when digital input DI1 closes for driver A and DI2 for driver B. See paragraph 4.2;
- VPM:** to enable control of the drivers via VPM, set "Enable EVD control" to 1; this is included in the safety parameters, in the special parameters menu, under the corresponding access level. However, the setup parameters should first be set in the related menu. The drivers will then be enabled for operation and control will be able to commence when requested by the pCO controller via LAN or when digital input DI1/DI2 closes. If due to error or for any other reason "Enable EVD control" should be set to 0 (zero), the controller will immediately stop control and will remain in standby until re-enabled, with the valve stopped in the last position;
- SUPERVISOR:** to simplify the commissioning of a considerable number of controllers using the supervisor, the setup operation on the display can be limited to simply setting the network address. The display will then be able to be removed and the configuration procedure postponed to a later stage using the supervisor or, if necessary, reconnecting the display. To enable control of the controller via supervisor, set "Enable EVD control"; this is included in the safety parameters, in the special parameters menu, under the corresponding access level. However, the setup parameters should first be set in the related menu. The controller will then be enabled for operation and control will be able to commence when requested by the pCO controller via pLAN or when digital input DI1 closes for driver A and DI2 for driver B. As highlighted on the supervisor, inside of the yellow information field relating to the "Enable EVD control" parameter, if due to error or for any other reason "Enable EVD control" should be set to 0 (zero), the controller will immediately stop control and will remain in standby until re-enabled, with the valve stopped in the last position;
- pCO PROGRAMMABLE CONTROLLER:** the first operation to be performed, if necessary, is to set the network address using the display.

! Important: for the driver with pLAN serial port, see the guidelines described in the following paragraph for setting the address.

If a pLAN, tLAN or RS485/Modbus® controller is used, connected to a pCO family controller, the setup parameters will not need to be set and confirmed. In fact, the application running on the pCO will manage the correct values based on the unit controlled. Consequently, simply set the pLAN, tLAN or RS485/Modbus® address for the controller as required by the application on the pCO, and after a few seconds communication will commence between the two instruments and the controller automatically will be enabled for control. The main screen will shown on the display, which can then be removed, and control will be commence when requested by the pCO controller or digital input DI1 for driver A and DI2 for driver B. (see paragraph 6.3). If there is no communication between the pCO and the controller (see the paragraph "LAN error alarm"), this will be able to continue control based on the status of the digital inputs.

4.2 Setting the pLAN network address

The pLAN addresses of the devices in the network must be assigned according to the following rule:

- the EVD Evolution driver addresses must be assigned in increasing order from left to right, starting with the controllers (A),
- then the drivers (B) and finally
- the terminals (C).

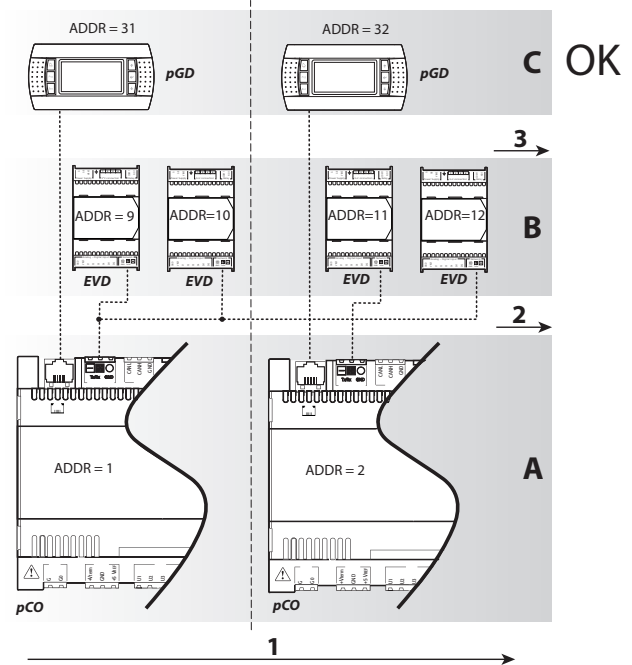

Fig. 4.a

! Important: if the addresses are not assigned in this way, as for example shown in the following figure, malfunctions will occur if one of the pCO controllers is offline.

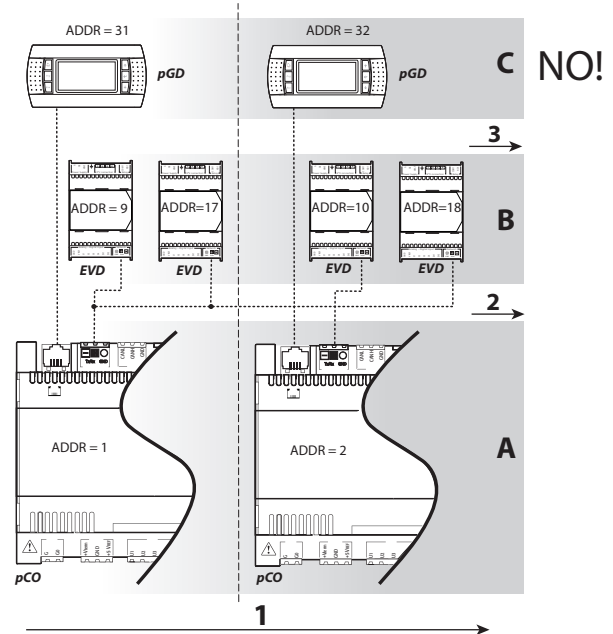
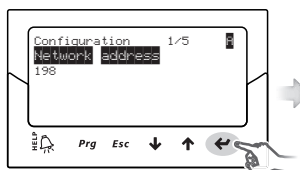

Fig. 4.b

4.3 Guided commissioning procedure (display)

After having fitted the display:



1. the first parameter is displayed: network address;
2. press Enter to move to the value of the parameter

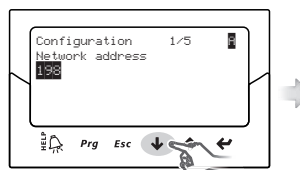

3. press UP/DOWN to modify the value



4. press Enter to confirm the value

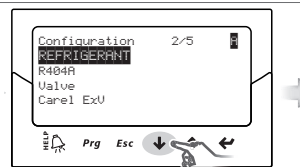

5. press UP/DOWN to move to the next parameter, refrigerant for driver A, indicated by the letter at the top right;

6. repeat steps 2, 3, 4, 5 to modify the values of the parameters for driver A: refrigerant, valve, pressure probe S1, main control;

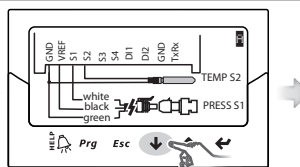

7. check that the probe electrical connections are correct for driver A;

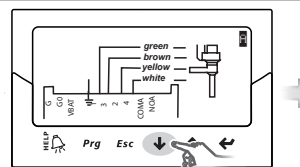

8. check that the electrical connections are correct for valve A; then set the same parameters for driver B (see step 6);

9. set the values of the parameters for driver B: refrigerant, valve B, pressure probe S3, main control;

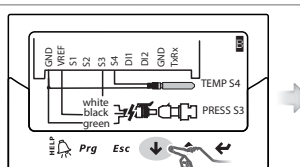

10. check that the probe electrical connections are correct for driver B;

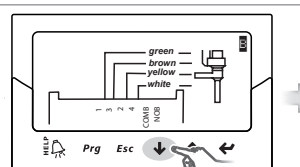

11. check that the electrical connections are correct for valve B;

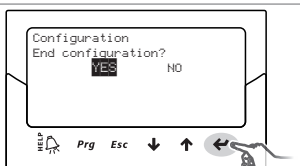

12. if the configuration is correct exit the procedure, otherwise choose NO and return to step 2.

At the end of the configuration procedure the controller activates the valve motor error recognition procedure, displaying "INIT" on the display. See paragraph 9.5. To simplify commissioning and avoid possible malfunctions, the controller will not start until the following have been configured for each driver:

4. network address (common parameter);
5. refrigerant;
6. valve;
7. pressure probe;
8. type of main control, that is, the type of unit the superheat control is applied to.

Note:

- to exit the guided commissioning procedure press the DOWN button repeatedly and finally confirm that configuration has been completed. The guided procedure CANNOT be ended by pressing Esc;
- if the configuration procedure ends with a configuration error, access Service parameter programming mode and modify the value of the parameter in question;
- if the valve and/or the pressure probe used are not available in the list, select any model and end the procedure. Then the controller will be enabled for control, and it will be possible to enter Manufacturer programming mode and set the corresponding parameters manually. Below are the parameters for driver A and driver B to be set during the commissioning procedure. **These parameters have the same description for both driver A and driver B, the user can recognise which parameter is being set by the letter A/B shown at the top right of the display.**

Important: for 24 Vdc power supply, at the end of the guided commissioning procedure, to start control set "Power supply mode" parameter=1, otherwise the valves remain in the closed position. See paragraph 6.1.

Network address

The network address assigns to the controller an address for the serial connection to a supervisory system via RS485, and to a pCO controller via pLAN, tLAN, RS485/Modbus®. This parameter is common to both drivers A and B.

| Parameter/description | Def. | Min. | Max. | UOM |
|-----------------------|------|------|------|-----|
| CONFIGURATION | | | | |
| Network address | 198 | 1 | 207 | - |

Tab. 4.a

For network connection of the RS485/Modbus® models the communication speed also needs to be set, in bits per second, using the parameter "Network settings". See paragraph 6.2.

Refrigerant

The type of refrigerant is essential for calculating the superheat. In addition, it is used to calculate the evaporation and condensing temperature based on the reading of the pressure probe.

| Parameter/description | Def. |
|-----------------------|-------------|
| CONFIGURATION | |
| Refrigerant | R404A |
| 0 = user definer | |
| 1= R22 | 2= R134a |
| 3= R404A | 4= R407C |
| 5= R410A | |
| 6= R507A | 7= R290 |
| 8= R600 | 9= R600a |
| 10= R717 | |
| 11= R744 | 12= R728 |
| 13= R1270 | 14= R417A |
| 15= R422D | |
| 16= R413A | 17= R422A |
| 18= R423A | 19= R407A |
| 20= R427A | |
| 21= R245FA | 22= R407F |
| 23=R32 | 24=HTR01 |
| 25= HTR02 | |
| 26=R23 | 27= R1234yf |
| 28= R1234ze | 29= R455A |
| 30= R170 | |
| 31= R442A | 32= R447A |
| 33= R448A | 34= R449A |
| 35= R450A | |
| 36= R452A | 37= R508B |
| 38= R452B | 39= R513A |
| 40= R454B | |
| 41= R458A | |

Tab. 4.b

Note:

- for CO₂ cascade systems, at the end of the commissioning procedure also set the auxiliary refrigerant. See the following paragraph Appendix 2;
- if the refrigerant is not among those available for the "Refrigerant" parameter:
 1. set any refrigerant (e.g. leave the default, R404A);
 2. select the model of valve, the pressure probe S1, the type of main control and end the commissioning procedure;
 3. enter programming mode and set the type of refrigerant: custom, and the parameters "Dew a...f high" and "Bubble a...f low" that define the refrigerant;
 4. start control, for example by closing the digital input contact to enable operation.

Valve

Setting the type of valve automatically defines all the control parameters based on the manufacturer's data for each model. In Manufacturer programming mode, the control parameters can then be fully customised if the valve used is not in the standard list. In this case, the controller will detect the modification and indicate the type of valve as "Customised".

| Parameter/description | Def. |
|---|-----------|
| CONFIGURATION | |
| Valve: | CAREL EXV |
| 0= user defined; 1= CAREL EXV; 2= Alco EX4; 3=Alco EX5; 4=Alco EX6; 5=Alco EX7; 6=Alco EX8 330 Hz recommended CAREL; 7=Alco EX8 500 Hz specific Alco; 8=Sporlan SEI 0.5-11; 9=Sporlan SER 1.5-20; 10=Sporlan SEI 30; 11=Sporlan SEI 50; 12=Sporlan SEH 100; 13=Sporlan SEH 175; 14=Danfoss ETS 12.5-25B; 15=Danfoss ETS 50B; 16=Danfoss ETS 100B; 17=Danfoss ETS 250; 18=Danfoss ETS 400; 19=Two EXV CAREL connected together; 20=Sporlan SER(I)G,J,K; 21= Danfoss CCM 10-20-30; 22= Danfoss CCM 40; 23=Danfoss CCMT 2-4-8; 24 = Disabled | |

Tab. 4.c

Note: select Valve = disabled if Main control = I/O expansion for pCO to prevent the EEV motor error from being displayed. I/O expansion for pCO control can be selected at the end of the commissioning procedure, by entering programming mode.

Important:

- two CAREL EXV valves connected together must be selected if two CAREL EXV valves are connected to the same terminal, to have parallel or complementary operation;
- as described, control is only possible with CAREL EXV valves;
- NOT all CAREL valves can be connected: see paragraph 2.5.

Pressure/refrigerant level probe S1 & S3

Setting the type of pressure probe S1 for driver A and S3 for driver B defines the range of measurement and the alarm limits based on the manufacturer's data for each model, usually indicated on the rating plate on the probe.

Select "CAREL liquid level" and connect the CAREL float level sensor to manage the following functions:

- evaporator liquid level control with CAREL sensor;
- condenser liquid level control with CAREL sensor.

For example, connecting two CAREL liquid level probes, one to S1 and one to S3, allows independent control of two refrigerant liquid levels.

See the chapter on "Control".

| Parameter/description | Def. |
|------------------------------------|----------------------------------|
| CONFIGURATION | |
| Probe S1, S3 | Ratiom.: -1 to 9.3 barg |
| 1= -1 to 4.2 barg | 8= -0.5 to 7 barg |
| 2= -0.4...9.3 barg | 9= 0 to 10 barg |
| 3= -1 to 9.3 barg | 10= 0 to 18.2 barg |
| 4= 0 to 17.3 barg | 11= 0 to 25 barg |
| 5= 0.85 to 34.2 barg | 12= 0 to 30 barg |
| 6= 0 to 34.5 barg | 13= 0 to 44.8 barg |
| 7= 0 to 45 barg | 14= remote, -0.5 to 7 barg |
| | 15= remote, 0 to 10 barg |
| | 16= remote, 0 to 18.2 barg |
| | 17= remote, 0 to 25 barg |
| | 18= remote, 0 to 30 barg |
| | 19= remote, 0 to 44.8 barg |
| | 20= External signal (4 to 20 mA) |
| 21= -1 to 12.8 barg | |
| 22= 0 to 20.7 barg | |
| 23= 1.86 to 43.0 barg | |
| 24 = CAREL liquid level | |
| 25 = 0..60,0 barg | |
| 26 = 0..90,0 barg | |
| 27 = external signal (0 to 5 V)(*) | |

Tab. 4.d

(*) for programmable positioner. See chapter "Control".

Important: if two pressure probes S1 and S3 are installed, these must be the same type. A ratiometric probe and an electronic probe cannot be used together.

Note: in the case of multiplexed systems where the same pressure probe is shared between the twin1 and twin2 controllers, choose the normal option for driver A and the "remote" option for the remaining drivers.

Example: to use the same pressure probe P1 for driver A and B: 4 to 20 mA, -0.5 to 7 barg

For driver A on the twin 1 controller select: 4 to 20 mA, -0.5 to 7 barg.

For driver B on the twin 1 controller and for driver A and B on the twin 2 controller select: remote 4 to 20 mA, -0.5 to 7 barg.

The connection diagram is shown in paragraph 2.6

Note:

- the range of measurement by default is always in bar gauge (barg). In the manufacturer menu, the parameters corresponding to the range of measurement and the alarms can be customised if the probe used is not in the standard list. If modifying the range of measurement, the controller will detect the modification and indicate the type of probe S1 or S3 as "Customised";
- the software on the controller takes into consideration the unit of measure. If a range of measurement is selected and then the unit of measure is changed (from bars to psi), the controller automatically updates the limits of the range of measurement and the alarm limits. By default, the main control probes S2 and S4 are set as "CAREL NTC". Other types of probes can be selected in the service menu;
- unlike the pressure probes, the temperature probes do not have any modifiable parameters relating to the range of measurement, and consequently only the models indicated in the list can be used (see the chapter on "Functions" and the list of parameters). In any case, in manufacturer programming mode, the limits for the probe alarm signal can be customised.

Main control

Setting the main control defines the operating mode for each driver.

| Parameter/description | Def. |
|---|-------------|
| CONFIGURATION | |
| Main control | |
| Superheat control | |
| 1= multiplexed showcase/cold room | multiplexed |
| 2= showcase/cold room with compressor on board | showcase/ |
| 3= "perturbed" showcase/cold room | cold room |
| 4= showcase/cold room with sub-critical CO ₂ | |
| 5= R404A condenser for sub-critical CO ₂ | |
| 6= air-conditioner/chiller with plate heat exchanger | |
| 7= air-conditioner/chiller with tube bundle heat exchanger | |
| 8= air-conditioner/chiller with finned coil heat exchanger | |
| 9= air-conditioner/chiller with variable cooling capacity | |
| 10= "perturbed" air-conditioner/chiller | |
| Special control | |
| 11= EPR back pressure | |
| 12= hot gas bypass by pressure | |
| 13= hot gas bypass by temperature | |
| 14= transcritical CO ₂ gas cooler | |
| 15= analogue positioner (4 to 20 mA) | |
| 16= analogue positioner (0 to 10 V) | |
| 17= air-conditioner/chiller or showcase/cold room with adaptive control | |
| 18= air-conditioner/chiller with Digital Scroll compressor (*) | |
| 19=AC/chiller with BLDC scroll compressor (CANNOT BE SELECTED) | |
| 20=superheat regulation with 2 temperature probes (CANNOT BE SELECTED) | |
| 21=I/O expander for pCO | |
| 22= Programmable SH regulation | |
| 23= Programmable special regulation | |
| 24= Programmable positioner | |
| 25= Evaporator liquid level regulation with CAREL sensor | |
| 26= Condenser liquid level regulation with CAREL sensor | |
| (*) only for CAREL valves controls | |

Tab. 4.e

The superheat set point and all the parameters corresponding to PID control, the operation of the protectors and the meaning and use of probes S1/S3 and/or S2/S4 will be automatically set to the values recommended by CAREL based on the selected application.

During this initial configuration phase, only superheat control mode from 1 to 10 can be set, which differ based on the application (chiller, refrigerated cabinet, etc.).

In the event of errors in the initial configuration, these parameters can later be accessed and modified inside the service or manufacturer menu.

If the controller default parameters are restored (RESET procedure, see the chapter on Installation), when next started the display will again show the guided commissioning procedure.

4.4 Checks after commissioning

After commissioning:

- check that the valves complete a full closing cycle to perform alignment;
- set, if necessary, in Service or Manufacturer programming mode, the superheat set point (otherwise keep the value recommended by CAREL based on the application) and the protection thresholds (LOP, MOP, etc.). See the chapter on Protectors.

4.5 Other functions

By entering Service programming mode, other types of main control can be selected (transcritical CO₂, hot gas bypass, etc.), as well as so-called special control functions, and suitable values set for the control set point and the LowSH, LOP and MOP protection thresholds (see the chapter on "Protectors"), which depend on the specific characteristics of the unit controlled.

By entering Manufacturer programming mode, finally, the operation of the controller can be completely customised, setting the function of each parameter. If the parameters corresponding to PID control are modified, the controller will detect the modification and indicate the main control as "Customised".

5. CONTROL

5.1 Main control

EVD evolution twin features two types of control, which can be set independently for driver A and B. Main control defines the operating mode of the driver. The first 10 settings refer to superheat control, the others are so-called "special" settings and are pressure or temperature settings or depend on a control signal from an external controller. The last special functions (18, 19, 20) also relate to superheat control, but they can be selectable if EVD Evolution TWIN is working as single driver (see Appendix 2). Programmable control exploits CAREL's technology and know-how in terms of control logic. Finally, it is possible to control liquid level in applications with flooded evaporator/condenser.

| Parameter/Description | Def. |
|---|------------------------|
| CONFIGURATION | |
| Main control | multiplexed |
| Superheat control | |
| 1= multiplexed showcase/cold room | showcase/ cold room |
| 2= showcase/cold room with compressor on board | |
| 3= "perturbed" showcase/cold room | |
| 4= showcase/cold room with sub-critical CO ₂ | |
| 5= R404A condenser for sub-critical CO ₂ | |
| 6= air-conditioner/chiller with plate heat exchanger | |
| 7= air-conditioner/chiller with tube bundle heat exchanger | |
| 8= air-conditioner/chiller with finned coil heat exchanger | |
| 9= air-conditioner/chiller with variable cooling capacity | |
| 10= "perturbed" air-conditioner/chiller | |
| Special control | |
| 11= EPR back pressure | |
| 12= hot gas bypass by pressure | |
| 13= hot gas bypass by temperature | |
| 14= transcritical CO ₂ gas cooler | |
| 15= analogue positioner (4 to 20 mA) | |
| 16= analogue positioner (0 to 10 V) | |
| 17= air-conditioner/chiller or showcase/cold room with adaptive control | |
| 18= air-conditioner/chiller with Digital Scroll compressor (*) | |
| 19=AC/chiller with BLDC scroll compressor (CANNOT BE SELECTED) | |
| 20=superheat regulation with 2 temperature probes (CANNOT BE SELECTED) | |
| 21=I/O expander for pCO (**) | |
| 22= Programmable SH regulation | |
| 23= Programmable special regulation | |
| 24= Programmable positioner | |
| 25= Evaporator liquid level regulation with CAREL sensor | |
| 26= Condenser liquid level regulation with CAREL sensor | |

(*) only for CAREL valve drivers; (**) control only settable on driver A, however corresponds to the entire controller.

Tab. 5.a

Note:

- R404A condensers with subcritical CO₂ refer to superheat control for valves installed in cascading systems where the flow of R404A (or other refrigerant) in an exchanger acting as the CO₂ condenser needs to be controlled;
- "perturbed" cabinet/cold room or air-conditioner/chiller refer to units that momentarily or permanently operate with swinging condensing or evaporation pressure;
- for the Auxiliary control setting see Appendix 2

The following paragraphs explain all the types of control that can be set on EVD evolution twin.

5.2 Superheat control

The primary purpose of the electronic valve is ensure that the flow-rate of refrigerant that flows through the nozzle corresponds to the flow-rate required by the compressor. In this way, the evaporation process will take place along the entire length of the evaporator and there will be no liquid at the outlet and consequently in the branch that runs to the compressor.

As liquid is not compressible, it may cause damage to the compressor and even breakage if the quantity is considerable and the situation lasts some time.

Superheat control

The parameter that the control of the electronic valve is based on is the superheat temperature, which effectively tells whether or not there is liquid at the end of the evaporator. EVD Evolution twin can independently manage superheat control on two refrigerant circuits. The superheat temperature is calculated as the difference between: superheated gas temperature (measured by a temperature probe located at the end of the evaporator) and the saturated evaporation temperature (calculated based on the reading of a pressure transducer located at the end of the evaporator and using the Tsat(P) conversion curve for each refrigerant).

$$\text{Superheat} = \text{Superheated gas temperature}^{\ast} - \text{Satur. evaporation temperature}^{\ast\ast} \text{ suction}$$

If the superheat temperature is high it means that the evaporation process is completed well before the end of the evaporator, and therefore flow-rate of refrigerant through the valve is insufficient. This causes a reduction in cooling efficiency due to the failure to exploit part of the evaporator. The valve must therefore be opened further. Vice-versa, if the superheat temperature is low it means that the evaporation process has not concluded at the end of the evaporator and a certain quantity of liquid will still be present at the inlet to the compressor. The valve must therefore be closed further. The operating range of the superheat temperature is limited at the lower end: if the flow-rate through the valve is excessive the superheat measured will be near 0 K. This indicates the presence of liquid, even if the percentage of this relative to the gas cannot be quantified. There is therefore an undetermined risk to the compressor that must be avoided. Moreover, a high superheat temperature as mentioned corresponds to an insufficient flow-rate of refrigerant. The superheat temperature must therefore always be greater than 0 K and have a minimum stable value allowed by the valve-unit system. A low superheat temperature in fact corresponds to a situation of probable instability due to the turbulent evaporation process approaching the measurement point of the probes. The expansion valve must therefore be controlled with extreme precision and a reaction capacity around the superheat set point, which will almost always vary from 3 to 14 K. Set point values outside of this range are quite infrequent and relate to special applications.

Example of superheat control on two independent circuits A and B.

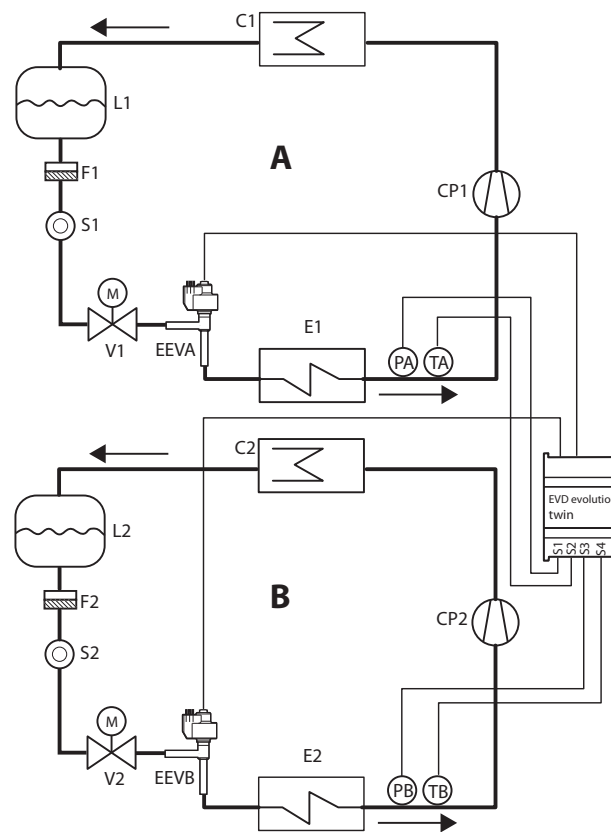

Fig. 5.a

Key:

| | |
|------------|--------------------------------|
| CP1, CP2 | compressor 1,2 |
| C1, C2 | condenser 1, 2 |
| L1, L2 | liquid receiver 1, 2 |
| F1, F2 | dewatering filter 1, 2 |
| S1, S2 | liquid indicator 1, 2 |
| EEVA, EEVB | electronic expansion valve A,B |
| V1, V2 | solenoid valve 1, 2 |
| E1, E2 | evaporator 1, 2 |
| PA, PB | pressure probe |
| TA, TB | temperature probe |

For the wiring, see paragraph "General connection diagram".

Another application involves superheat control of two evaporators in the same circuit.

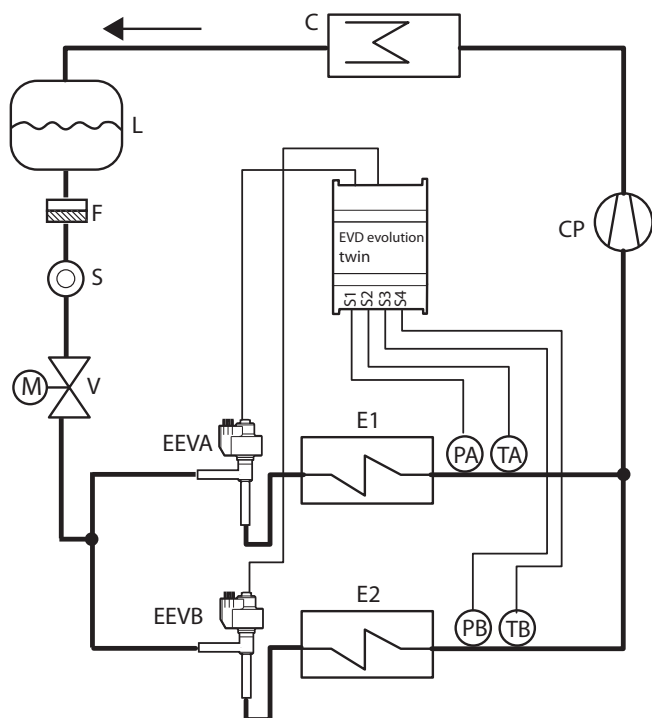

Fig. 5.b

Key:

| | |
|--------|-------------------------------|
| CP | compressor |
| C | condenser |
| L | liquid receiver |
| F | dewatering filter |
| S | liquid indicator |
| EEVA, | electronic expansion valve A |
| EEVB | electronic expansion valve B |
| E1, E2 | evaporator 1, 2 |
| PA, PB | pressure probe driver A, B |
| TA, TB | temperature probe driver A, B |
| V | solenoid valve |

For the wiring, see paragraph "General connection diagram".

Nota: in this example only one electronic pressure transducer with 4 to 20 mA output (SPK**0000) can be used, shared between driver A and B. Ratiometric transducers cannot be shared.

Another possibility involves connecting two equal valves (operation in parallel mode, see paragraph 2.5) to the same evaporator. This is useful in reverse-cycle chiller/heat pump applications, to improve distribution of the refrigerant in the outdoor coil.

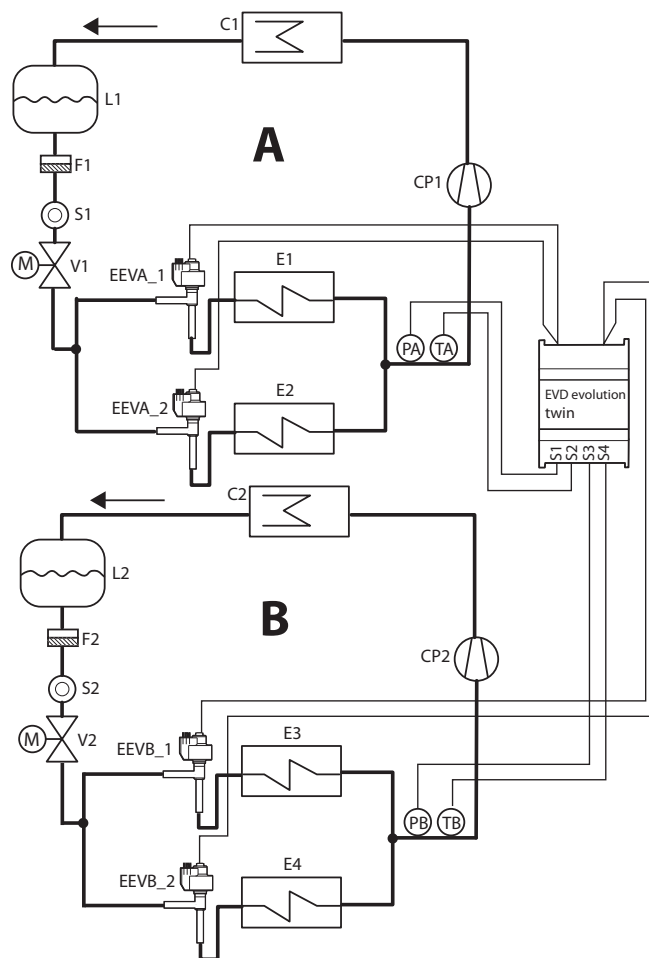

Fig. 5.c

Key:

| | |
|----------------|--------------------------------------|
| CP1,2 | compressor 1, 2 |
| C1,C2 | condenser 1, 2 |
| E1, E2, E3, E4 | evaporator 1, 2, 3, 4 |
| F1, F2 | dewatering filter 1, 2 |
| S1, S2 | liquid indicator 1, 2 |
| EEVA_1, | electronic expansion valves driver A |
| EEVA_2 | |
| EEVB_1, | electronic expansion valves driver B |
| EEVB_2 | |
| TA, TB | temperature probe |
| L1, L2 | liquid receiver 1, 2 |
| V1, V2 | solenoid valve 1, 2 |

For the wiring, see paragraph "General connection diagram".

PID parameters

Superheat control, as for any other mode that can be selected with the "main control" parameter, is performed using PID control, which in its simplest form is defined by the law:

$$u(t) = K \left(e(t) + \frac{1}{T_i} \int e(t) dt + T_d \frac{de(t)}{dt} \right)$$

Key:

| | | | |
|------|-------------------|----|-----------------|
| u(t) | Valve position | Ti | Integral time |
| e(t) | Error | Td | Derivative time |
| K | Proportional gain | | |

Note that control is calculated as the sum of three separate contributions: proportional, integral and derivative.

- the proportional action opens or closes the valve proportionally to the variation in the superheat temperature. Thus the greater the K (proportional gain) the higher the response speed of the valve. The proportional action does not consider the superheat set point, but rather only reacts to variations. Therefore if the superheat value does not vary significantly, the valve will essentially remain stationary and the set point cannot be reached;
- the integral action is linked to time and moves the valve in proportion to the deviation of the superheat value from the set point. The greater the deviations, the more intense the integral action; in addition, the lower the value of T (integral time), the more intense the action will be. The integration time, in summary, represents the intensity of the reaction of the valve, especially when the superheat value is not near the set point;
- the derivative action is linked to the speed of variation of the superheat value, that is, the gradient at which the superheat changes from instant to instant. It tends to react to any sudden variations, bringing forward the corrective action, and its intensity depends on the value of the time T (derivative time).

| Parameter/Description | Def. | Min. | Max. | UOM |
|------------------------|------|------------------|-----------|-------|
| CONTROL | | | | |
| Superheat set point | 11 | LowSH: threshold | 180 (324) | K(°F) |
| PID: proportional gain | 15 | 0 | 800 | - |
| PID: integral time | 150 | 0 | 1000 | s |
| PID: derivative time | 5 | 0 | 800 | s |

Tab. 5.b

See the "EEV system guide" +030220810 for further information on calibrating PID control.

Note: when selecting the type of main control (both superheat control and special modes), the PID control values suggested by CAREL will be automatically set for each application.

Protection function control parameters

See the chapter on "Protectors". Note that the protection thresholds are set by the installer/manufacturer, while the times are automatically set based on the PID control values suggested by CAREL for each application.

| Parameter/Description | Def. | Min. | Max. | UOM |
|---------------------------------|------|----------------|----------------|---------|
| CONTROL | | | | |
| LowSH protection: threshold | 5 | -40 (-72) | SH set point | K (°F) |
| LowSH protection: integral time | 15 | 0 | 800 | s |
| LOP protection: threshold | -50 | -60 (-76) | MOP: threshold | °C (°F) |
| LOP protection: integral time | 0 | 0 | 800 | s |
| MOP protection: threshold | 50 | LOP: threshold | 200 (392) | °C (°F) |
| MOP protection: integral time | 20 | 0 | 800 | s |

Tab. 5.c

5.3 Adaptive control and autotuning

Note: from the software revision following the 6.6-6.7, functions "Adaptive control" and "Autotuning" are no longer present. Then the setting:
Main control= air-conditioner/chiller or cabinet/ cold room with adaptive control, is equivalent to:
Main control = multiplexed cabinet/cold room.

EVD evolution TWIN features two functions used to automatically optimise the PID parameters for superheat control, useful in applications where there are frequent variations in thermal load:

1. automatic adaptive control: the function continuously evaluates the effectiveness of superheat control and activates one or more optimisation procedures accordingly;
2. manual autotuning: this is activated by the user and involves just one optimisation procedure.

Both procedures give new values to the PID superheat control and protection function parameters:

- PID: proportional gain;
- PID: integral time;
- PID: derivative time;
- LowSH: low superheat integral time;
- LOP: low evaporation temperature integral time;
- MOP: high evaporation temperature integral time.

Given the highly variable dynamics of superheat control on different units, applications and valves, the theories on stability that adaptive control and autotuning are based on are not always definitive. As a consequence, the following procedure is suggested, in which each successive step is performed if the previous has not given a positive outcome:

1. use the parameters recommended by CAREL to control the different units based on the values available for the "Main control" parameter;
2. use any parameters tested and calibrated manually based on laboratory or field experiences with the unit in question;
3. enable automatic adaptive control;
4. activate one or more manual autotuning procedures with the unit in stable operating conditions if adaptive control generates the "Adaptive control ineffective" alarm.

Adaptive control

After having completed the commissioning procedure, to activate adaptive control, set the parameter:

"Main control"= air-conditioner/chiller or showcase/cold room with adaptive control

| Parameter/Description | Def. |
|---|--------------------------------|
| CONFIGURATION | |
| Main control | multiplexed showcase/cold room |
| ... | |
| air-conditioner/chiller or showcase/cold room with adaptive control | |

Tab. 5.d

The activation status of the tuning procedure will be shown on the standard display by the letter "T".

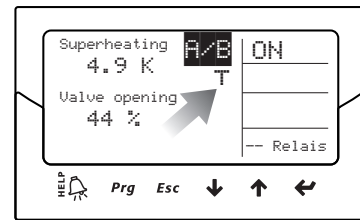

Fig. 5.d

With adaptive control enabled, the controller constantly evaluates whether control is sufficiently stable and reactive; otherwise the procedure for optimising the PID parameters is activated. The activation status of the optimisation function is indicated on the standard display by the message "TUN" at the top right.

The PID parameter optimisation phase involves several operations on the valve and readings of the control variables so as to calculate and validate the PID parameters. These procedures are repeated to fine-tune superheat control as much as possible, over a maximum of 12 hours.

- Note:
- during the optimisation phase maintenance of the superheat set point is not guaranteed, however the safety of the unit is ensured through activation of the protectors. If these are activated, the procedure is interrupted;
 - if all the attempts performed over 12 hours are unsuccessful, the "adaptive control ineffective" alarm will be signalled and adaptive control will be disabled, resetting the default values of the PID and protection function parameters;
 - to deactivate the "adaptive control ineffective" alarm set the value of the "main control" parameter to one of the first 10 options. If required, adaptive control can be immediately re-enabled using the same parameter. If the procedure ends successfully, the resulting control parameters will be automatically saved.

Autotuning

EVD evolution TWIN also features an automatic tuning function (Autotuning) for the superheat and protector control parameters, which can be started by setting the parameter "Force manual tuning" = 1.

| Parameter/Description | Def. | Min. | Max. | UOM |
|-----------------------|------|------|------|-----|
| SPECIAL | | | | |
| Force manual tuning | 0 | 0 | 1 | - |
| 0 = no; 1 = yes | | | | |

Tab. 5.e

The activation status of the procedure is indicated on the standard display by the message "TUN" at the top right.

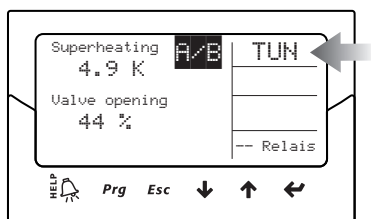

Fig. 5.e

The optimisation procedure can only be performed if the driver is in control status, and lasts from 10 to 40 minutes, performing specific movements of the valve and measurements of the control variables.

Note:

- during the function maintenance of the superheat set point is not guaranteed, however the safety of the unit is ensured through activation of the protectors. If these are activated, the procedure is interrupted;
- if, due to external disturbance or in the case of particularly unstable systems, the procedure cannot suitably optimise the parameters, the controller will continue using the parameters saved in the memory before the procedure was started. If the procedure ends successfully, the resulting control parameters will be automatically saved.
- both the tuning procedure and adaptive control can only be enabled for superheat control, they cannot be used for the special control functions

For CAREL internal use only, some tuning procedure control parameters can be shown on the display, supervisor, pCO and VPM; these must not be modified by non-expert users.

These are:

- Tuning method
- Adaptive control status
- Last tuning result

| Parameter/Description | Def. | Min. | Max. | UOM |
|-----------------------|------|------|------|-----|
| SPECIAL | | | | |
| Tuning method | 0 | 0 | 255 | - |

Tab. 5.f

Tuning method is visible as a parameter in the Special category, the two other parameters are visible in display mode. See paragraph 3.4.

Note: the "Tuning method" parameter is for use by qualified CAREL technical personnel only and must not be modified.

5.4 Control with Emerson Climate Digital Scroll™ compressor

Important: this type of control is incompatible with adaptive control and autotuning.

Digital Scroll compressors allow wide modulation of cooling capacity by using a solenoid valve to active a patented refrigerant bypass mechanism. This operation nonetheless causes swings in the pressure of the unit, which may be amplified by normal control of the expansion valve, leading to malfunctions. Dedicated control ensures greater stability and efficiency of the entire unit by controlling the valve and limiting swings based on the instant compressor modulation status. To be able to use this mode, the LAN version driver must be connected to a Carel pCO series controller running a special application to manage units with Digital scroll compressors.

| Parameter/Description | Def. |
|--|--------------------------------|
| CONFIGURATION | |
| Main control | multiplexed showcase/cold room |
| ... | |
| air-conditioner/chiller with Digital Scroll compressor | |

Tab. 5.g

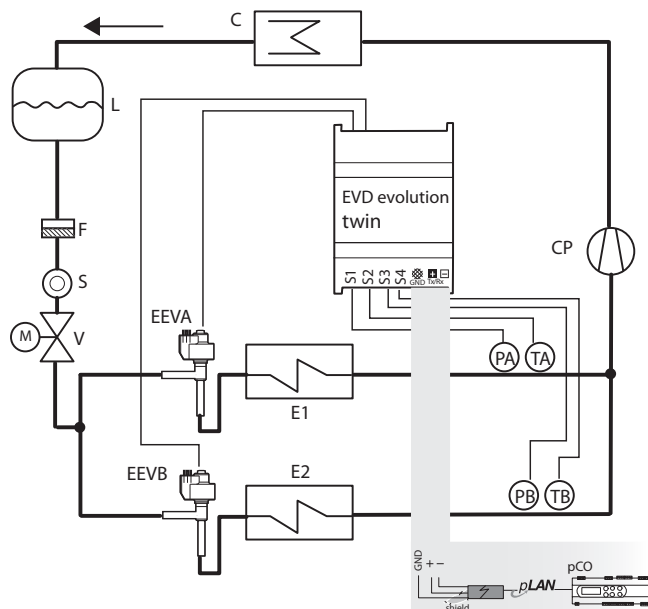

Fig. 5.f

Key:

| | | | |
|--------|--------------------|--------|----------------------------|
| CP | Compressor | V | Solenoid valve |
| C | Condenser | S | Liquid gauge |
| L | Liquid receiver | EEV | Electronic expansion valve |
| F | Dewatering filter | E1, E2 | Evaporator |
| TA, TB | Temperature probes | PA, PB | Pressure probes |

For information on the wiring see paragraph "General connection diagram".

5.5 Special control

EPR back pressure

This type of control can be used in applications in which a constant pressure is required in the refrigerant circuit. For example, a refrigeration system may include different showcases that operate at different temperatures (showcases for frozen foods, meat or dairy). The different temperatures of the circuits are achieved using pressure regulators installed in series with each circuit. The special EPR function (Evaporator Pressure Regulator) is used to set a pressure set point and the PID control parameters required to achieve this.

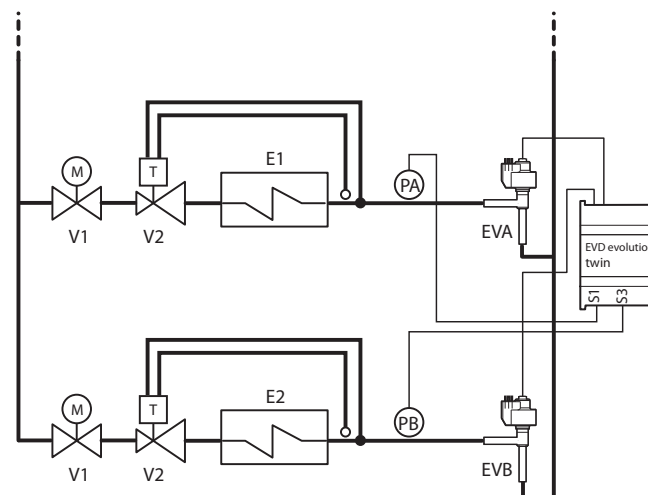

Fig. 5.g

Key:

| | | | |
|--------|------------------------------|----------|-----------------------|
| V1 | Solenoid valve | E1, E2 | Evaporator 1, 2 |
| V2 | Thermostatic expansion valve | EVA, EVB | Electronic valve A, B |
| PA, PB | Pressure probe driver A, B | | |

For the wiring, see paragraph "General connection diagram".

This involves PID control without any protectors (LowSH, LOP, MOP, see the chapter on Protectors), without any valve unblock procedure. Control is performed on the pressure probe value read by input S1 for driver A and S3 for driver B, compared to the set point: "EPR pressure set point". Control is direct, as the pressure increases, the valve opens and vice-versa.

| Parameter/Description | Def. | Min. | Max. | UOM |
|------------------------|------|------------|------------|-------------|
| CONTROL | | | | |
| EPR pressure set point | 3.5 | -20 (-290) | 200 (2900) | barg (psig) |
| PID: proportional gain | 15 | 0 | 800 | - |
| PID: integral time | 150 | 0 | 1000 | s |
| PID: derivative time | 5 | 0 | 800 | s |

Tab. 5.h

Hot gas bypass by pressure

This control function can be used to control cooling capacity, which in the following example is performed by driver B. If there is no request from circuit Y, the compressor suction pressure decreases and the bypass valve opens to let a greater quantity of hot gas flow and decrease the capacity of circuit X. Driver A is used for superheat control on circuit Y.

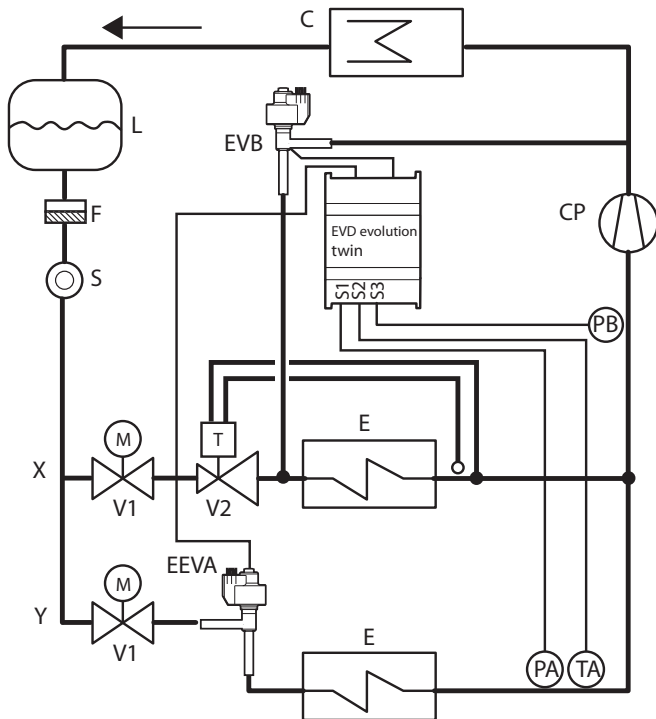

Fig. 5.h

Key:

| | | | |
|----|-------------------|------|------------------------------|
| CP | Compressor | V1 | Solenoid valve |
| C | Condenser | V2 | Thermostatic expansion valve |
| L | Liquid receiver | EEVA | Electronic expansion valve A |
| F | Dewatering filter | EVB | Electronic valve B |
| S | Liquid indicator | E | Evaporator |

For the wiring, see paragraph "General connection diagram".

This involves PID control without any protectors (LowSH, LOP, MOP, see the chapter on Protectors), without any valve unblock procedure. Control is performed on the hot gas bypass pressure probe value read by input S3, compared to the set point: "Hot gas bypass pressure set point". Control is reverse, as the pressure increases, the valve closes and vice-versa.

| Parameter/Description | Def. | Min. | Max. | UOM |
|-----------------------------------|------|-----------|------------|-------------|
| CONTROL | | | | |
| Hot gas bypass pressure set point | 3 | -20 (290) | 200 (2900) | barg (psig) |
| PID: proportional gain | 15 | 0 | 800 | - |
| PID: integral time | 150 | 0 | 1000 | s |
| PID: derivative time | 5 | 0 | 800 | s |

Tab. 5.i

Hot gas bypass by temperature

This control function can be used to control cooling capacity, which in the following example is performed by driver B. On a refrigerated cabinet, if the ambient temperature probe S4 measures an increase in the temperature, the cooling capacity must also increase, and so the EVB valve must close. In the example driver A is used for superheat control.

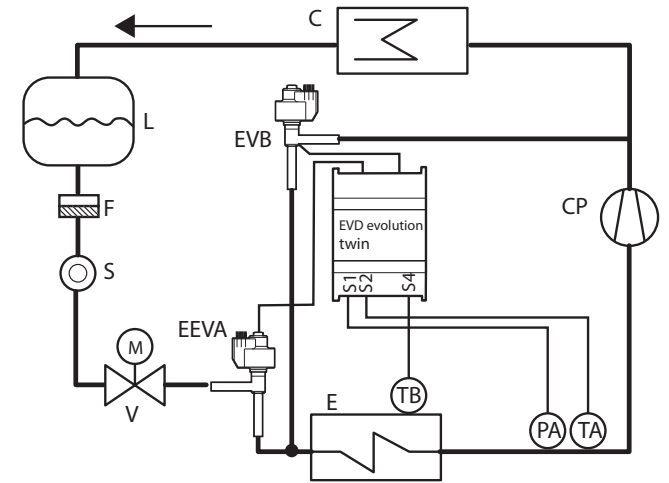

Fig. 5.i

Key:

| | | | |
|--------|-------------------|------|------------------------------|
| CP | Compressor | V | Solenoid valve |
| C | Condenser | EEVA | Electronic expansion valve A |
| L | Liquid receiver | EVB | Electronic valve B |
| F | Dewatering filter | E | Evaporator |
| S | Liquid indicator | PA | Pressure probe driver A |
| TA, TB | Temperature probe | | |

For the wiring, see paragraph "General connection diagram".

This involves PID control without any protectors (LowSH, LOP, MOP, see the chapter on Protectors), without any valve unblock procedure. Control is performed on the hot gas bypass temperature probe value read by input S4, compared to the set point: "Hot gas bypass temperature set point". Control is reverse, as the temperature increases, the valve closes.

| Parameter/Description | Def. | Min. | Max. | UOM |
|--------------------------------------|------|-----------|-----------|---------|
| CONTROL | | | | |
| Hot gas bypass temperature set point | 10 | -60 (-76) | 200 (392) | °C (°F) |
| PID: proportional gain | 15 | 0 | 800 | - |
| PID: integral time | 150 | 0 | 1000 | s |
| PID: derivative time | 5 | 0 | 800 | s |

Tab. 5.j

Another application that exploits this control function uses the connection of two EXV valves together to simulate the effect of a three-way valve, called "reheating". To control humidity, valve EVB_2 is opened to let the refrigerant flow into exchanger S. At the same time, the air that flows through evaporator E is cooled and the excess humidity removed, yet the temperature is below the set room temperature. It then flows through exchanger S, which heats it back to the set point (reheating). In addition, if dehumidification needs to be increased, with less cooling, valve EVA_2 must open to bypass at least some of the refrigerant to condenser C. The refrigerant that reaches the evaporator thus has less cooling capacity. Valves EVA_1 and EVA_2 are also connected together in complementary mode, controlled by the 4 to 20 mA signal on input S1, from an external regulator.

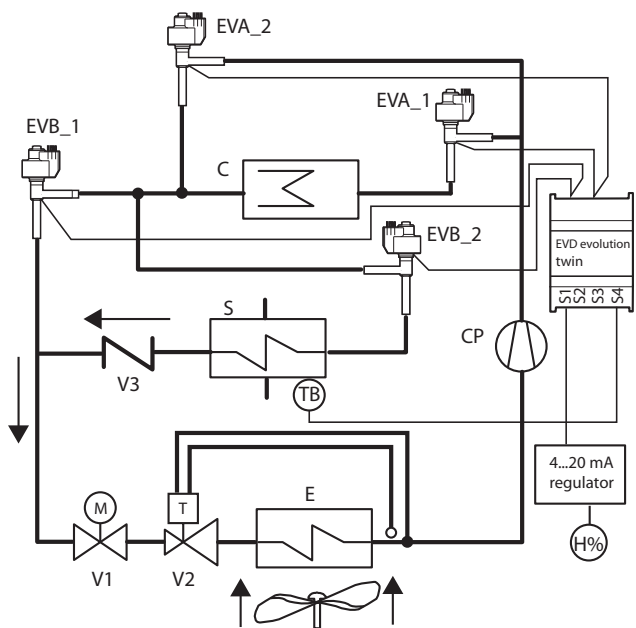

Fig. 5.j

Key:

| | | | |
|----|----------------------------|----------|---|
| CP | Compressor | EVA_1, 2 | Electronic valves connected in complementary mode |
| C | Condenser | H% | Relative humidity probe |
| V1 | Solenoid valve | TB | Temperature probe |
| V3 | Non-return valve | E | Evaporator |
| S | Heat exchanger (reheating) | V2 | Thermostatic expansion valve |

For the wiring, see paragraph "General connection diagram".

Transcritical CO₂ gas cooler

This solution for the use of CO₂ in refrigerating systems with a transcritical cycle involves using a gas cooler, that is a refrigerant/air heat exchanger resistant to high pressures, in place of the condenser.

In transcritical operating conditions, for a certain gas cooler outlet temperature, there is pressure that optimises the efficiency of the system:

$$Set = A \cdot T + B$$

Set = pressure set point in a gas cooler with transcritical CO₂

T = gas cooler outlet temperature

Default value: A=3.3, B=-22.7.

In the simplified diagram shown below control is performed by driver A and the simplest solution in conceptual terms is shown. The complications in the systems arise due to the high pressure and the need to optimise efficiency. Driver B is used for superheat control.

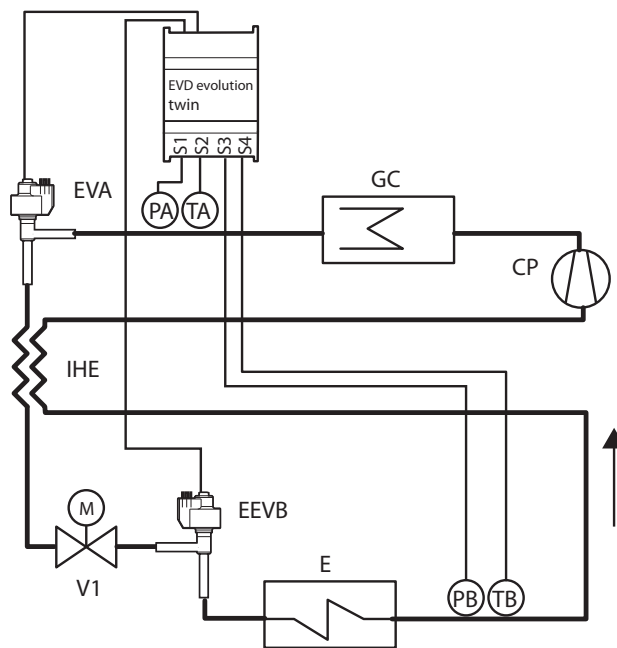

Fig. 5.k

Key:

| | | | |
|----|----------------|------|------------------------------|
| CP | Compressor | EVA | Electronic valve A |
| GC | Gas cooler | EEVB | Electronic expansion valve B |
| E | Evaporator | IHE | Inside heat exchanger |
| V1 | Solenoid valve | | |

For the wiring, see paragraph "General connection diagram".

This involves PID control without any protectors (LowSH, LOP, MOP, see the chapter on Protectors), without any valve unblock procedure. Control is performed on the gas cooler pressure probe value read by input S1, with a set point depending on the gas cooler temperature read by input S2; consequently there is not a set point parameter, but rather a formula: "CO₂ gas cooler pressure set point" = Coefficient A * Tgas cooler (S2) + Coefficient B. The set point calculated will be a variable that is visible in display mode. Control is direct, as the pressure increases, the valve opens.

| Parameter/Description | Def. | Min. | Max. | UOM |
|---|-------|------|------|-----|
| SPECIAL | | | | |
| Transcritical CO ₂ : coefficient A | 3.3 | -100 | 800 | - |
| Transcritical CO ₂ : coefficient B | -22.7 | -100 | 800 | - |
| CONTROL | | | | |
| PID: proportional gain | 15 | 0 | 800 | |
| PID: integral time | 150 | 0 | 1000 | s |
| PID: derivative time | 5 | 0 | 800 | s |

Tab. 5.k

Analogue positioner (4 to 20 mA)

This control function is available for driver A and driver B. Valve A will be positioned linearly depending on the value of the "4 to 20 mA input for analogue valve positioning" read by input S1.

Valve B will be positioned linearly depending on the value of the "4 to 20 mA input for analogue valve positioning" read by input S3.

There is no PID control nor any protection (LowSH, LOP, MOP, see the chapter on Protectors), and no valve unblock procedure.

Forced closing will only occur when digital input DI1 opens for driver A or DI2 for driver B, thus switching between control status and standby. The pre-positioning and repositioning procedures are not performed. Manual positioning can be enabled when control is active or in standby.

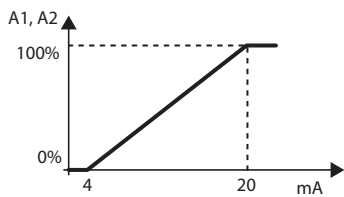
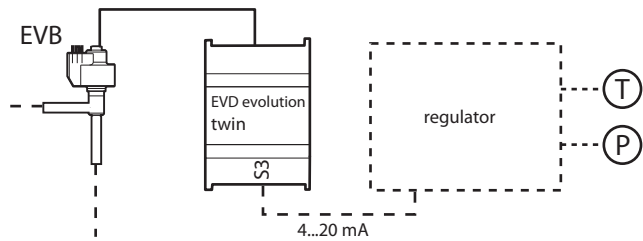
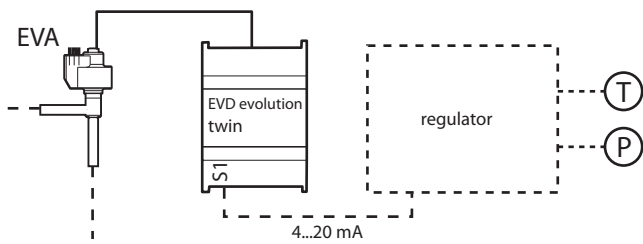

Fig. 5.l

Key:

| | | | |
|-----|--------------------|----|-----------------|
| EVA | Electronic valve A | A1 | Valve opening A |
| EVB | Electronic valve B | A2 | Valve opening B |

For the wiring, see paragraph "General connection diagram".

Analogue positioner (0 to 10 Vdc)

This control function is only available for driver A. The valve will be positioned linearly depending on the value of the "0 to 10 V input for analogue valve positioning" read by input S2.

There is no PID control nor any protection (LowSH, LOP, MOP), and no valve unblock procedure. The opening of digital input DI1 stops control on driver A, with corresponding forced closing of the valve and changeover to standby status.

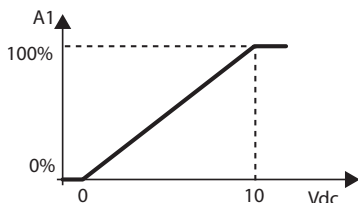
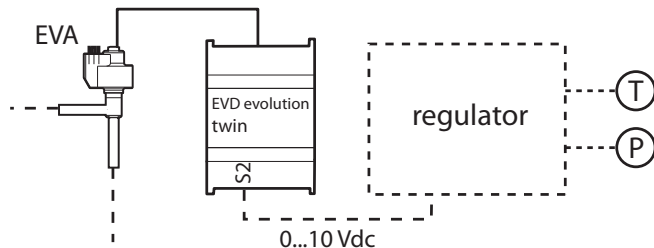

Fig. 5.m

Key:

| | | | |
|-----|--------------------|----|-----------------|
| EVA | Electronic valve A | A1 | Valve opening A |
|-----|--------------------|----|-----------------|

For the wiring, see paragraph "General connection diagram".

! Important: the pre-positioning and repositioning procedures are not performed. Manual positioning can be enabled when control is active or in standby.

I/O expander for pCO

The EVD Evolution driver is connected to the pCO programmable controller via LAN, transferring the probe readings quickly and without filtering. The driver operates as a simple actuator, and receives the information needed to manage the valves from the pCO.

| Parameter/Description | Def. |
|-----------------------|--------------------------------|
| CONFIGURATION | |
| Main control | multiplexed showcase/cold room |
| ... | |
| I/O expander for pCO | |

Tab. 5.l

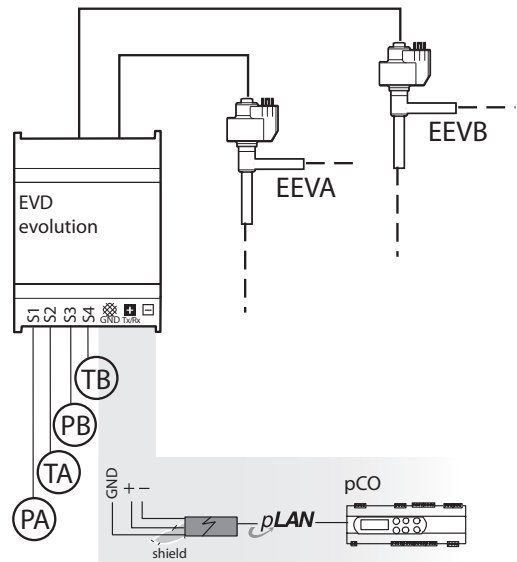

Fig. 5.n

Key:

| | | | |
|----|-------------------|---|----------------|
| T | Temperature probe | P | Pressure probe |
| EV | Electronic valve | | |

5.6 Programmable control

With programmable control, the unused probe can be exploited to activate an auxiliary control function and maximise the controller's potential. The following types of programmable control are available:

- Programmable superheat control (SH);
- Programmable special control;
- Programmable positioner.

| Parameter/description | Def | Min | Max | U.M. |
|-------------------------------------|---------------------------------|------------------|----------------|------|
| CONFIGURATION | | | | |
| Main control | Multiplexed cabinet / cold room | - | - | - |
| ... | | | | |
| 22= Programmable SH control ; | | | | |
| 23 = Programmable special control ; | | | | |
| 24 = Programmable positioner | | | | |
| ... | | | | |
| SPECIAL | | | | |
| Programmable control configuration | 0 | 0 | 32767 | - |
| Programmable control input | 0 | 0 | 32767 | - |
| Programmable SH control options | 0 | 0 | 32767 | - |
| Programmable control set point | 0 | -800 (-11603) | 800 (11603) | |

Tab. 5.m

The table shows the programmable control functions and the related parameter settings.

| Function | Parameter to be set |
|--|------------------------------|
| Direct/reverse setting | Programmable control config. |
| Type of physical value controlled | Programmable control config. |
| Input processing to determine measur. | Programmable control config. |
| Correction to each individual input for integration in measurement calculation | Programmable control input |
| Association between physical inputs and logical outputs | Programmable control input |

 Note: the control error is the result of the difference between the set point and the measurement:

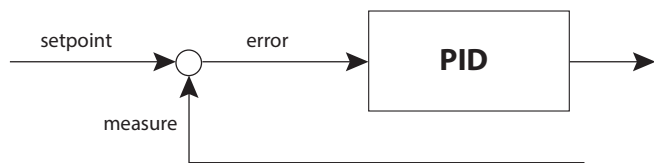

Direct operation: error = measurement - set point
Reverse operation: error = set point - measurement

Programmable control configuration

 Important: for the explanation of the HiTcond (high condensing temperature), reverse HiTcond protectors and the “Modulating thermostat” auxiliary control function, see Appendix 2.

Each digit in the “Programmable control configuration” parameter has a special meaning, depending on its position:

| POSITION | DESCRIPTION | NOTE |
|------------------------|-------------------------|---|
| Tens of thousands (DM) | Control: direct/reverse | Select type of control action: direct/reverse |
| Thousands (M) | Auxiliary control | Selection any auxiliary control or protector used for superheat control |
| Hundreds | Do not select | - |
| Tens | Controlled value | Select the type of controlled physical value (temperature, pressure...) |
| Units | Measurement function | Select the function for calculating the value controlled by the PID (measurement) |

Tab. 5.a

Direct/reverse control – Tens of thousands

| Value | Description |
|--------|------------------------|
| 0 | PID in direct control |
| 1 | PID in reverse control |
| 2,...9 | - |

AUX control - Thousands

| Value | Description |
|--------|-------------------------------|
| 0 | None |
| 1 | HITCond protection |
| 2 | Modulating thermostat |
| 3 | HITCond protection in reverse |
| 4,...9 | - |

Hundreds – DO NOT SELECT

Controlled value - Tens

| Value | Description |
|-------|--------------------------------|
| 0 | Temperature (°C/°F), absolute |
| 1 | Temperature (K/°F), relative |
| 2 | Pressure (bar/psi), absolute |
| 3 | Pressure (barg/psig), relative |
| 4 | Current (mA) for control |
| 5 | Voltage (V) for control |
| 6 | Voltage (V) for positioner |
| 7 | Current (mA) for positioner |
| 8,9 | - |

Measurement function - Units

| Value | Description |
|--------|--------------------------------|
| 0 | f1(S1)+ f2(S2)+ f3(S3)+ f4(S4) |
| 1,...9 | - |

Programmable control input

The function assigned to each input is defined by parameter - “Programmable control input”. The parameter has 16 bits and is divided into 4 digits, as described in “Programmable control configuration”, corresponding to the 4 probes, S1, S2, S3, S4.

| POSITION | DESCRIPTION |
|-----------|----------------------|
| Thousands | Function of probe S1 |
| Hundreds | Function of probe S2 |
| Tens | Function of probe S3 |
| Units | Function of probe S4 |

| Value | Input function |
|-------|-----------------|
| 0 | 0 |
| 1 | + Sn |
| 2 | - Sn |
| 3 | + Tdew (Sn)(*) |
| 4 | - Tdew (Sn) |
| 5 | + Ttub (Sn)(**) |
| 6 | - Ttub (Sn) |
| 7,8,9 | - |

(*): Tdew() = function for calculating the saturated evaporation temperature according to the type of gas.

(**): Tbubble = function for calculating the condensing temperature.

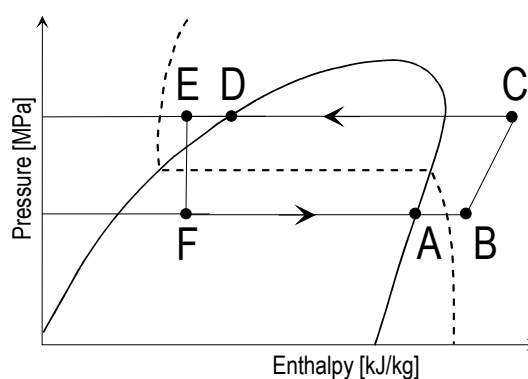

Fig. 5.o

Key:

| | |
|---------|---|
| TA | Saturated evaporation temperature = Tdew |
| TB | Superheated gas temperature = suction temperature |
| TB – TA | Superheat |
| TD | Condensing temperature (Tbubble) |
| TE | Subcooled gas temperature |
| TD – TE | Subcooling |

Options/ programmable control set point

 Note:

- if Control = Programmable special control, the setting of the “Programmable control options” parameter has no affect;
- if Control = “Programmable positioner”, the settings of the “Programmable control options” and “Programmable control set point” parameters have no affect.

The physical value measured is assigned to the individual probes S1 to S4 by the “Programmable control options” parameter. The parameter has 16 bits and is divided into 4 digits, as described in “Programmable control configuration”, corresponding to the 4 probes, S1, S2, S3, S4. The control set point si sets to the “Programmable control set point” parameter.

| POSITION | DESCRIPTION |
|-----------|----------------------|
| Thousands | Function of probe S1 |
| Hundreds | Function of probe S2 |
| Tens | Function of probe S3 |
| Units | Function of probe S4 |

| Value | Input function |
|-------|-------------------------------------|
| 0 | None |
| 1 | Suction temperature |
| 2 | Evaporation pressure |
| 3 | Evaporation temperature |
| 4 | Condensing pressure |
| 5 | Condensing temperature |
| 6 | Temperature (modulating thermostat) |
| 7,8,9 | - |

Note: if several inputs are associated with the same logical meaning, EVD Evolution considers the one associated with the input that has the highest index.

Examples

EXAMPLE 1

Sharing of the 0 to 10 V input to control two valves in parallel with the same input.

- Main control_1 = 0 to 10 V programmable positioner;
Main control_2 = 0 to 10 V programmable positioner.
- Programmable control configuration_1 = 00060; PID control function = $f(S1)+f(S2)+f(S3)+f(S4)$. The other settings not affect.
Programmable control configuration_2 = 00060; PID control function = $f(S1)+f(S2)+f(S3)+f(S4)$;
- Programmable control input_1 = 0100 ->Measurement =S2
Programmable control input_2 = 0100 ->Measurement =S2
- Programmable control options_1 = XXXX, no affect
Programmable control options_2 = XXXX, no affect
- Programmable control set point_1 = XX, no affect
Programmable control set point_2 = XX, no affect

EVD Evolution twin shares the input associated with probe 2 and moves the two valves in parallel.

EXAMPLE 2

Superheat control with hot gas bypass by temperature. Programmable control is used to add the high condensing temperature protection (HiTCond).

- Main control_1 = 22 -> Programmable SH control;
- Main control_2 = 13 -> Hot gas bypass by temperature.
- Programmable control configuration_1=01010,
1) Direct PID temperature control;
2) HiTcond control enabled;
3) Temperature (°F/psig), absolute;
4) Measurement function: $f1(S1)+f2(S2)+f3(S3)+f4(S4)$;
- Programmable control input_1 = 4100-> Measurement =-Tdew(S1)+S2
- Programmable control options_1 = 2140
1) S1 = Evaporation pressure
2) S2 = Suction temperature
3) S3 = Condensing pressure
4) S4 = Not used
- Programmable control set point_1 = 10 K

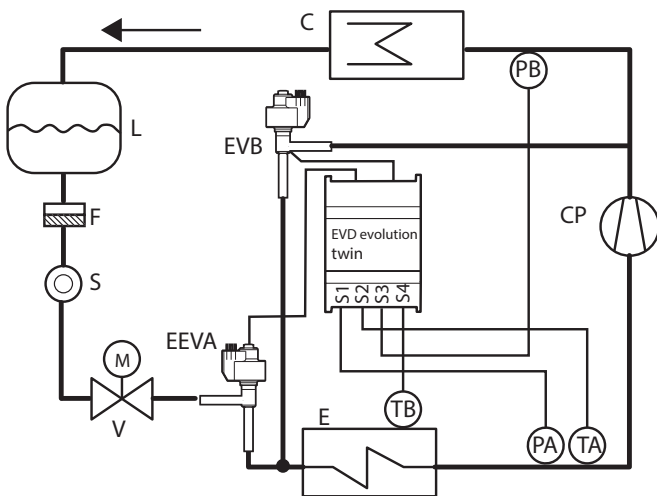

Fig. 5.p

5.7 Control with refrigerant level sensor

In the flooded shell and tube evaporator and in the flooded condenser, the refrigerant vaporises outside of the tubes, which are immersed in the liquid refrigerant. The hot fluid flowing through the tubes is cooled, transferring heat to the refrigerant surrounding the tubes, so that this boils, with gas exiting from the top, which is taken in by the compressor.

| Parameter/description | Def | Min | Max | UOM |
|--|-------------------------------|-----|-----|-----|
| CONFIGURATION | | | | |
| Probe S1 | Ratiometric:-1...9.3 barg | - | - | - |
| ... | | | | |
| 24 = CAREL liquid level | | | | |
| ... | | | | |
| Main control | Multiplexed cabinet/cold room | - | - | - |
| ... | | | | |
| 26 = Evaporator liquid level control with CAREL sensor | | | | |
| 27 = Condenser liquid level control with CAREL sensor | | | | |
| CONTROL | | | | |
| Liquid level set point | 50 | 0 | 100 | % |

The action is reverse: if the liquid level measured by the float level sensor is higher (lower) than the set point, the EEV valve closes (opens).

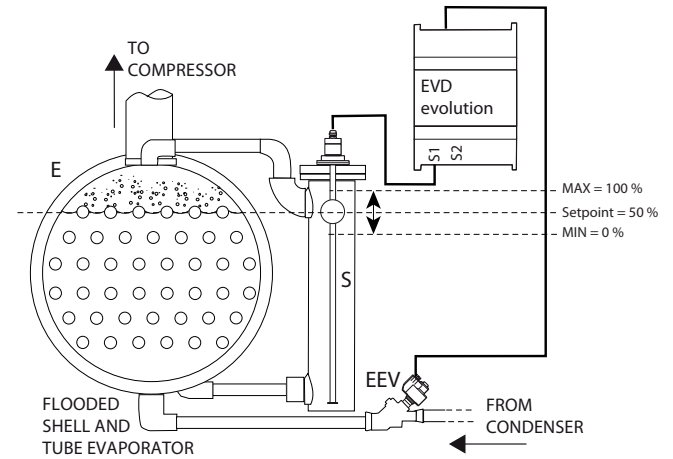

Fig. 5.q

Key:

| | |
|-----|--------------------|
| S | Float level sensor |
| EEV | Electronic valve |
| E | Flooded evaporator |

For the wiring, see paragraph "General connection diagram".

With the condenser, the action is direct: if the liquid level measured by the float level sensor is lower (higher) than the set point, the EEV valve closes (opens).

6. FUNCTIONS

6.1 Power supply mode

EVD evolution twin can be powered at 24 Vac or 24 Vdc. In the event of direct current power supply, after completing the commissioning procedure, to start control set "Power supply mode" parameter=1.

| Parameter/Description | Def. | Min. | Max. | UOM |
|-----------------------|------|------|------|-----|
| SPECIAL | | | | |
| Power supply mode | 0 | 0 | 1 | - |
| 0=24 Vac | | | | |
| 1= 24 Vdc | | | | |

Tab. 6.a

Important: with direct current power supply, in the event of power failures emergency closing of the valve is not performed, even if the EVD0000UC0 module is connected.

6.2 Battery charge delay

Battery charge delay to allow battery charging. In the presence of a battery to close the valve, to avoid missing emergency closing in case of repeated and close blackouts, a regulation start delay has been introduced, configurable by the user depending on the backup system used (ultracap or lead battery). This delay, if set to a value > 0, occurs every time the driver is turned on to allow the battery to recharge.

| Parameter/description | Def. |
|-----------------------|-------|
| ADVANCED | |
| Battery charge delay | 0 min |

6.3 Network connection

Important: to set the pLAN address, follow the guidelines in chap.4.

To connect an RS485/Modbus® controller to the network, as well as the network address parameter (see paragraph 4.2), using the "Network settings" parameter.

| Parameter | Description | Def. |
|-------------------|-------------|------------|
| SPECIAL | | |
| Set configuration | parity | Bit stop |
| 0 | none parity | 2 bit stop |
| 1 | none parity | 2 bit stop |
| 2 | none parity | 2 bit stop |
| 4 | none parity | 1 bit stop |
| 5 | none parity | 1 bit stop |
| 6 | none parity | 1 bit stop |
| 16 | even parity | 2 bit stop |
| 17 | even parity | 2 bit stop |
| 18 | even parity | 2 bit stop |
| 20 | even parity | 1 bit stop |
| 21 | even parity | 1 bit stop |
| 22 | even parity | 1 bit stop |
| 24 | odd parity | 2 bit stop |
| 25 | odd parity | 2 bit stop |
| 26 | odd parity | 2 bit stop |
| 28 | odd parity | 1 bit stop |
| 29 | odd parity | 1 bit stop |
| 30 | odd parity | 1 bit stop |

Tab. 6.b

Note: To use the Carel protocol you must use the default settings:

- byte size: 8 bits;
- stop bits: 2;
- parity: none.

6.4 Inputs and outputs

Analogue inputs

The parameters in question concern the choice of the type of pressure/liquid probe S1 and S3 and the choice of the temperature probe S2 and S4, as well as the possibility to calibrate the pressure and temperature signals. As regards the choice of pressure/liquid probe S1 and S3, see the chapter on "Commissioning".

Inputs S2, S4

The options are standard NTC probes, high temperature NTC, combined temperature and pressure probes and 0 to 10 Vdc input. For S4 the 0 to 10 Vdc input is not available. When choosing the type of probe, the minimum and maximum alarm values are automatically set. See the chapter on "Alarms".

| Type | CAREL code | Range |
|--------------------------------|------------|--------------------------------|
| CAREL NTC (10KΩ at 25°C) | NTCO**HP00 | -50T105°C |
| | NTCO**WF00 | |
| | NTCO**HF00 | |
| CAREL NTC-HT HT (50KΩ at 25°C) | NTCO**HT00 | 0T120°C (150 °C for 3000 h) |
| Combined NTC | SPKP**T0 | -40T120°C |
| NTC low temperature | NTC*LT* | -80T60°C |

Important: for combined NTC probes, also select the parameter relating to the corresponding ratiometric pressure probe.

| Parameter/description | Def. |
|--|-----------|
| CONFIGURATION | |
| Probe S2: | CAREL NTC |
| 1= CAREL NTC; 2= CAREL NTC-HT high T; 3= Combined NTC SPKP**T0; 4= 0 to 10 V external signal; 5=NTC – LT CAREL low temperature | |
| Probe S4: | CAREL NTC |
| 1= CAREL NTC; 2= CAREL NTC-HT high T; 3= Combined NTC SPKP**T0; 4 = ---; 5=NTC – LT CAREL low temperature | |

Tab. 6.c

Calibrating pressure probes S1, S3 and temperature probes S2 and S4 (offset and gain parameters)

If needing to be calibrate:

- the pressure probe, S1 and/or S3, the offset parameter can be used, which represents a constant that is added to the signal across the entire range of measurement, and can be expressed in barg/psig. If the 4 to 20 mA signal coming from an external controller on input S1 and/or S3 needs to be calibrated, both the offset and the gain parameters can be used, the latter which modifies the gradient of the line in the field from 4 to 20 mA.
- the temperature probe, S2 and/or S4, the offset parameter can be used, which represents a constant that is added to the signal across the entire range of measurement, and can be expressed in °C/°F. If the 0 to 10 Vdc signal coming from an external controller on input S2 needs to be calibrated, both the offset and the gain parameters can be used, the latter which modifies the gradient of the line in the field from 0 to 10 Vdc.

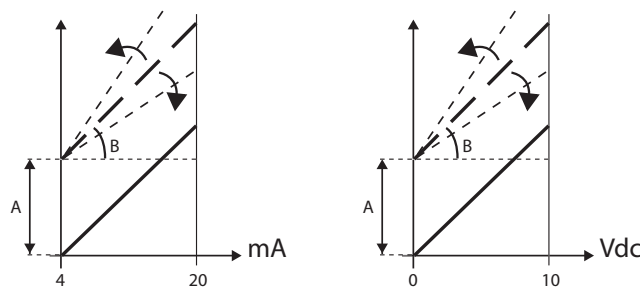

Fig. 6.a

Key:
A= offset, B= gain

| Parameter/description | Def. | Min. | Max. | UOM |
|----------------------------------|------|--------------------|-----------------|--------------------|
| Probes | | | | |
| S1: calibration offset | 0 | -60 (-870), -60 | 60 (870), 60 | barg (psig), mA |
| S1: calibration gain, 4 to 20 mA | 1 | -20 | 20 | - |
| S2: calibration offset | 0 | -20 (-36) | 20 (36) | °C (°F), volt |
| S2: calibration gain, 0 to 10 V | 1 | -20 | 20 | - |
| S3: calibration offset | 0 | -60 (-870) | 60 (870) | barg (psig) |
| S3: calibration gain, 4 to 20 mA | 1 | -20 | 20 | - |
| S4: calibration offset | 0 | -20 (-36) | 20 (36) | °C (°F) |

Tab. 6.d

Digital inputs

The functions of digital inputs 1 and 2 can be set by parameter, as shown in the table below:

| Parameter/description | Def. | Min. | Max. | UOM |
|--|------|------|------|-----|
| CONFIGURATION | | | | |
| DI1 configuration | 5/6 | 1 | 7 | - |
| 1= Disabled | | | | |
| 2= Valve regulation optimization after defrost | | | | |
| 3= Discharged battery alarm management | | | | |
| 4= Valve forced open (at 100%) | | | | |
| 5= Regulation start/stop | | | | |
| 6= Regulation backup | | | | |
| 7= Regulation security | | | | |
| CONTROL | | | | |
| Start delay after defrost | 10 | 0 | 60 | min |

Tab. 6.e

Valve regulation optimization after defrost: the selected digital input tells the driver the current defrost status.
 Defrost active = contact closed.
 Access Manufacturer programming mode to set the start delay after defrost; this parameter is common to both drivers.

Discharged battery alarm management: this setting can only be selected if the controller power supply is 24 Vac. If the selected digital input is connected to the battery charge module for EVD evolution, EVBAT00400, the controller signals discharged or faulty batteries, so as to generate an alarm message and warn the service technicians that maintenance is required.

Valve forced open: when the digital input closes, the valve opens completely (100%), unconditionally. When the contact opens again the valve closes and moves to the position defined by the parameter "valve opening at start-up" for the pre-position time. Control can then start.

Regulation start/stop:
 digital input closed: control active;
 digital input open: driver in standby (see the paragraph "Control status");

 **Important:** this setting excludes activation/deactivation of control via the network. See the following functions.

Regulation backup: if there is a network connection and communication fails, the driver checks the status of the digital input to determine whether control is active or in standby;

Regulation security: if there is a network connection, before control is activated the driver must receive the control activation signal and the selected digital input must be closed. If the digital input is open, the driver always remains in standby.

Priority of digital inputs

In certain cases the setting of digital inputs 1 and 2 may be incompatible (e.g. no regulation start/stop). The problem thus arises to determine which function each driver needs to perform.

Consequently, each type of function is assigned a priority, primary (PRIM) or secondary (SEC), as shown in the table:

| DI1/DI2 configuration | Type of function |
|---|------------------|
| 1=Disabled | SEC |
| 2=Valve regulation optimization after defrost | SEC |
| 3=Discharged battery alarm management | SEC |
| 4=Valve forced open (at 100%) | SEC |
| 5=Regulation start/stop | PRIM |
| 6=Regulation backup | PRIM |
| 7=Regulation security | PRIM |

There are four possible cases of digital input configurations with primary or secondary functions.

| Case | Function set | | Driver A | | Driver B | |
|------|--------------|------|--|-----|--|-----|
| | DI1 | DI2 | Function performed by digital input | | Function performed by digital input | |
| | | | PRIM | SEC | PRIM | SEC |
| 1 | PRIM | PRIM | DI1 | - | DI2 | - |
| 2 | PRIM | SEC | DI1 | DI2 | DI1 | - |
| 3 | SEC | PRIM | DI2 | - | DI2 | DI1 |
| 4 | SEC | SEC | Regulation backup driver A (supervisor variable) | DI1 | Regulation backup driver B (supervisor variable) | DI2 |

Note that:

- if digital inputs 1 and 2 are set to perform a PRIM function, driver A performs the function set by digital input 1 and driver B the function set by digital input 2;
- if digital inputs 1 and 2 are set to perform a PRIM and SEC function respectively, driver A and driver B perform the PRIM function set on digital input DI1. Driver A will also perform the SEC function set on digital input DI2;
- if digital inputs 1 and 2 are set to perform a SEC and PRIM function respectively, driver A and driver B perform the PRIM function set on digital input DI2. Driver B will also perform the SEC function set on digital input DI1;
- if digital inputs 1 and 2 are set to perform a SEC function, driver A will perform the SEC function set on input DI1 and driver B will perform the SEC function set on input DI2. Each driver will be set to "Regulation backup", with the value of the digital input determined respectively by the supervisor variables:
 - Regulation backup from supervisor (driver A);
 - Regulation backup from supervisor (driver B).

Examples

Example 1: assuming an EVD Evolution twin controller connected to the LAN. In this case, the start/stop control will come from the network.

The two digital inputs can be configured for:

1. valve regulation optimization after defrost (SEC function);
2. regulation backup (PRIM function).

With reference to the previous table:

- in case 2, when there is no communication both driver A and driver B will be enabled for control by digital input 1, and digital input 2 will determine when control stops to run the defrost for driver A only;
- in case 3 when there is no communication digital input 2 will activate control for both driver A and driver B. Digital input 1 will determine when control stops to run the defrost for driver B only.

Example 2: assuming an EVD Evolution twin controller in stand-alone operation. In this case, the start/stop control will come from the digital input. The following cases are possible:

1. start / stop driver A/B from inputs DI1/DI2 (case 1);
2. simultaneous start / stop of both drivers A/B from input DI1 (case 2); input DI2 can be used for discharged battery alarm management.

Relay outputs

The relay outputs can be configured as:

- alarm relay output. See the chapter on Alarms;
- solenoid valve control;
- electronic expansion valve status signal relay. The relay contact is only open if the valve is closed (opening=0%). As soon as control starts (opening >0%, with hysteresis), the relay contact is closed

| Parameter/description | Def. |
|--|-------------|
| CONFIGURATION | |
| Relay configuration: | |
| 1= Disabled; 2= Alarm relay (open when alarm active); | Alarm relay |
| 3= Solenoid valve relay (open in standby); 4= Valve + alarm relay (open in standby and control alarms) | |
| 5= Reversed alarm relay (closed in case of alarm); 6= Valve status relay (open if valve is closed); 7 = Direct control; 8=Failed closing alarm relay (opened with alarm); 9=Reverse failed closing alarm relay (closed with alarm) | |

Tab. 6.f

6.5 Control status

The electronic valve controller has 8 different types of control status, each of which may correspond to a specific phase in the operation of the refrigeration unit and a certain status of the controller-valve system.

The status may be as follows:

- **forced closing:** initialisation of the valve position when switching the instrument on;
- **standby:** no temperature control, unit OFF;
- **wait:** opening of the valve before starting control, also called pre-positioning, when powering the unit and in the delay after defrosting;
- **control:** effective control of the electronic valve, unit ON;
- **positioning:** step-change in the valve position, corresponding to the start of control when the cooling capacity of the controlled unit varies (only for LAN EVD connected to a pCO);
- **stop:** end of control with the closing of the valve, corresponds to the end of temperature control of the refrigeration unit, unit OFF;
- **valve motor error recognition:** see paragraph 9.5;
- **tuning in progress:** see paragraph 5.3

Forced closing

Forced closing is performed after the controller is powered-up and corresponds to a number of closing steps equal to the parameter "Closing steps", based on the type valve selected. This is used to realign the valve to the physical position corresponding to completely closed. The driver and the valve are then ready for control and both aligned at 0 (zero). On power-up, first a forced closing is performed, and then the standby phase starts.

| Parameter/description | Def. | Min. | Max. | UOM |
|-----------------------|------|------|------|------|
| VALVE | | | | |
| EEV closing steps | 500 | 0 | 9999 | step |

Tab. 6.g

The valve is closed in the event of power failures with 24 Vac power supply when the EVD0000UC0 module is connected. In this case, the parameter "Forced valve closing not completed", visible only on the supervisor, is forced to 1. If when restarting forced closing of the valve was not successful:

1. the Master programmable controller checks the value of the parameter and if this is equal to 1, decides the best strategy to implement based on the application;
2. EVD Evolution twin does not make any decision and positions the valve as explained in the paragraph "Pre-positioning/start control". The parameter is reset to 0 (zero) by the Master controller (e.g. pCO). EVD Evolution twin resets the parameter to 0 (zero) only if forced emergency closing is completed successfully

Standby

Standby corresponds to a situation of rest in which no signals are received to control the electronic valve. This normally occurs when:

- the refrigeration unit stops operating, either when switched off manually (e.g. from the button, supervisor) or when reaching the control set point;
- during defrosts, except for those performed by reversing of the cycle (or hot gas bypass).

In general, it can be said that electronic valve control is in standby when the compressor stops or the control solenoid valve closes. The valve is closed or open according to the setting of "Valve open in standby". The percentage of opening is set using "Valve position in standby".

In this phase, manual positioning can be activated.

| Parameter/description | Def. | Min. | Max. | UOM |
|---|------|------|------|-----|
| CONTROL | | | | |
| Valve open in standby 0=disabled=valve closed; 1=enabled = valve open 25% | 0 | 0 | 1 | - |
| Valve position in standby 0 = 25 % (*) 1...100% = % opening (**) | 0 | 0 | 100 | % |

Tab. 6.h

These two parameters determine the position of the valve in standby based on the minimum and maximum number of valve steps.

| Parameter/description | Def. | Min. | Max. | UOM |
|-----------------------|------|------|------|------|
| VALVE | | | | |
| Minimum EEV steps | 50 | 0 | 9999 | step |
| Maximum EEV steps | 480 | 0 | 9999 | step |

Tab. 6.i

(*) The formula used is:

$$\text{Apertura / Opening} = \frac{\text{Min_step_EEV} + (\text{Max_step_EEV} - \text{Min_step_EEV}) / 100 * 25}{\text{steps}}$$

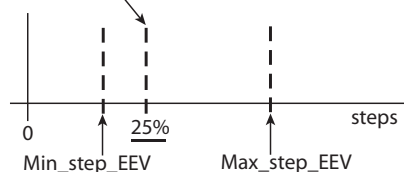

Fig. 6.b

(**) In this case, the formula used is:

$$\text{Apertura / Opening} = P * (\text{Max_step_EEV} / 100)$$

P = Posizione valvola in stand-by / Position valve in stand-by

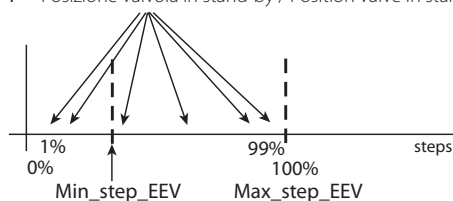

Fig. 6.c



Note: if "Valve open in standby=1", the positions of the valve when setting "Valve position in standby"=0 and 25 do not coincide. Refer to the above formulae.

Prepositioning/start control

If during standby a control request is received, before starting control the valve is moved to a precise initial position.

The pre-position time is the time the valve is held in a steady position based on the parameter "Valve opening at start-up".

| Parameter/description | Def. | Min. | Max. | UOM |
|---|------|------|-------|-----|
| CONTROL | | | | |
| Pre-position time | 6 | 0 | 18000 | s |
| Valve opening at start-up (evaporator/valve capacity ratio) | 50 | 0 | 100 | % |

Tab. 6.j

The valve opening parameter should be set based on the ratio between the rated cooling capacity of the evaporator and the valve (e.g. rated evaporator cooling capacity: 3kW, rated valve cooling capacity: 10kW, valve opening = 3/10 = 33%).

If the capacity request is 100%:

Opening (%)= (Valve opening at start-up);

If the capacity request is less than 100% (capacity control):

Opening (%)= (Valve opening at start-up) x (Current unit cooling capacity), where the current unit cooling capacity is sent to the driver via pLAN by the pCO controller. If the driver is stand-alone, this is always equal to 100%.



Note:

- this procedure is used to anticipate the movement and bring the valve significantly closer to the operating position in the phases immediately after the unit starts;
- if there are problems with liquid return after the refrigeration unit starts or in units that frequently switch on-off, the valve opening at start-up must be decreased. If there are problems with low pressure after the refrigeration unit starts, the valve opening must be increased.

Wait

When the calculated position has been reached, regardless of the time taken (this varies according to the type of valve and the objective position), there is a constant 5 second delay before the actual control phase starts. This is to create a reasonable interval between standby, in which the variables have no meaning, as there is no flow of refrigerant, and the effective control phase.

Control

The control request for each driver can be received, respectively, by the closing of digital input 1 or 2, via the network (LAN). The solenoid or the compressor are activated when the valve, following the pre-positioning procedure, has reached the calculated position. The following figure represents the sequence of events for starting control of the refrigeration unit.

Control delay after defrost

Some types of refrigerating cabinets have problems controlling the electronic valve in the operating phase after a defrost. In this period (10 to 20 min after defrosting), the superheat measurement may be altered by the high temperature of the copper pipes and the air, causing excessive opening of the electronic valve for extended periods, in which there is return of liquid to the compressors that is not detected by the probes connected to the driver. In addition, the accumulation of refrigerant in the evaporator in this phase is difficult to dissipate in a short time, even after the probes have started to correctly measure the presence of liquid (superheat value low or null).

The driver can receive information on the defrost phase in progress, via the digital input. The "Start delay after defrost" parameter is used to set a delay when control resumes so as to overcome this problem. During this delay, the valve will remain in the pre-positioning point, while all the normal probe alarm procedures, etc. are managed.

| Parameter/description | Def. | Min. | Max. | UOM |
|---------------------------|------|------|------|-----|
| CONTROL | | | | |
| Start delay after defrost | 10 | 0 | 60 | min |

Tab. 6.k

Important: if the superheat temperature should fall below the set point, control resumes even if the delay has not yet elapsed.

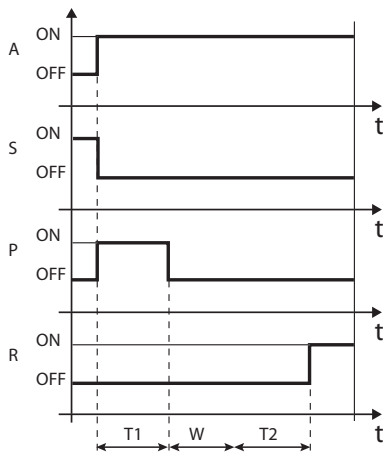

Fig. 6.d

Key:

| | | | |
|---|-----------------|----|---------------------------|
| A | Control request | W | Wait |
| S | Standby | T1 | Pre-position time |
| P | Pre-positioning | T2 | Start delay after defrost |
| R | Control | t | Time |

Positioning (change cooling capacity)

This control status is only valid for the pLAN controller. If there is a change in unit cooling capacity of at least 10%, sent from the pCO via the pLAN, the valve is positioned proportionally. In practice, this involves repositioning starting from the current position in proportion to how much the cooling capacity of the unit has increased or decreased in percentage terms. When the calculated position has been reached, regardless of the time taken (this varies according to the type of valve and the position), there is a constant 5 second delay before the actual control phase starts.

Note: if information is not available on the variation in unit cooling capacity, this will always be considered as operating at 100% and therefore the procedure will never be used. In this case, the PID control must be more reactive (see the chapter on Control) so as to react promptly to variations in load that are not communicated to the driver.

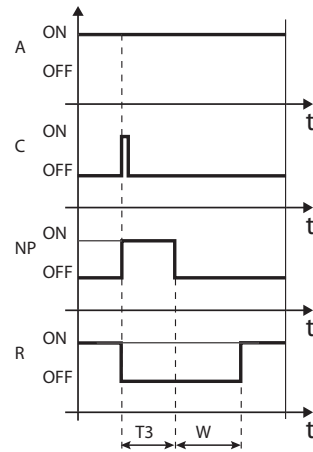

Fig. 6.e

Key:

| | | | |
|----|-----------------|----|--------------------|
| A | Control request | T3 | Repositioning time |
| C | Change capacity | W | Wait |
| NP | Repositioning | t | Time |
| R | Control | | |

Stop/end control

The stop procedure involves closing the valve from the current position until reaching 0 steps, plus a further number of steps so as to guarantee complete closing. Following the stop phase, the valve returns to standby.

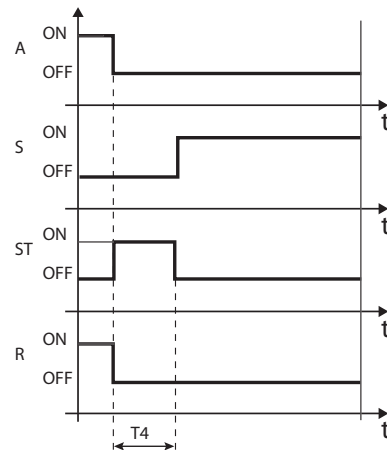

Fig. 6.f

Key:

| | | | |
|----|-----------------|----|--------------------|
| A | Control request | R | Control |
| S | Standby | T4 | Stop position time |
| ST | Stop | t | Time |

6.6 Special control status

As well as normal control status, the driver can have 3 special types of status related to specific functions:

- **manual positioning:** this is used to interrupt control so as to move the valve, setting the desired position;
- **recover physical valve position:** recover physical valve steps when fully opened or closed;
- **unblock valve:** forced valve movement if the driver considers it to be blocked.

Manual positioning

Manual positioning can be activated at any time during the standby or control phase. Manual positioning, once enabled, is used to freely set the position of the valve using the corresponding parameter.

| Parameter/Description | Def. | Min. | Max. | UOM |
|--|------|------|------|------|
| CONTROL | | | | |
| Enable manual valve positioning | 0 | 0 | 1 | - |
| Manual valve position | 0 | 0 | 9999 | step |
| Stop manual positioning on network error | 0 | 0 | 1 | - |

0 = Normal operation; 1 = Stop

Tab. 6.l

Control is placed on hold, all the system and control alarms are enabled, however neither control nor the protectors can be activated. Manual positioning thus has priority over any status/protection of the driver.

When the driver is connected to the network (for example to a pCO controller), in presence of an communication-error (LAN error), manual positioning can be inhibited temporarily by the parameter and the driver recognizes the start/stop regulation, depending on the configuration of the digital inputs.

Note:

- the manual positioning status is NOT saved when restarting after a power failure;
- in for any reason the valve needs to be kept stationary after a power failure, proceed as follows:
 - remove the valve stator;
 - in Manufacturer programming mode, under the configuration parameters, set the PID proportional gain =0. The valve will remain stopped at the initial opening position, set by corresponding parameter.

Recover physical valve position

| Parameter/Description | Def. | Min. | Max. | UOM |
|---------------------------------------|------|------|------|-----|
| VALVE | | | | |
| Synchronise valve position in opening | 1 | 0 | 1 | - |
| Synchronise valve position in closing | 1 | 0 | 1 | - |

Tab. 6.m

This procedure is necessary as the stepper motor intrinsically tends to lose steps during movement. Given that the control phase may last continuously for several hours, it is probable that from a certain time on the estimated position sent by the valve controller does not correspond exactly to the physical position of the movable element. This means that when the driver reaches the estimated fully closed or fully open position, the valve may physically not be in that position. The "Synchronisation" procedure allows the driver to perform a certain number of steps in the suitable direction to realign the valve when fully opened or closed.

Note:

- realignment is in intrinsic part of the forced closing procedure and is activated whenever the driver is stopped/started and in the standby phase;
- the possibility to enable or disable the synchronisation procedure depends on the mechanics of the valve. When the setting the "valve" parameter, the two synchronisation parameters are automatically defined. The default values should not be changed.

Unblock valve

This procedure is only valid when the driver is performing superheat control. Unblock valve is an automatic safety procedure that attempts to unblock a valve that is supposedly blocked based on the control variables (superheat, valve position). The unblock procedure may or may not succeed depending on the extent of the mechanical problem with the valve. If for 10 minutes the conditions are such as to assume the valve is blocked, the procedure is run a maximum of 5 times. The symptoms of a blocked valve do not necessarily mean a mechanical blockage. They may also represent other situations:

- mechanical blockage of the solenoid valve upstream of the electronic valve (if installed);
- electrical damage to the solenoid valve upstream of the electronic valve;
- blockage of the filter upstream of the electronic valve (if installed);
- electrical problems with the electronic valve motor;
- electrical problems in the driver-valve connection cables;
- incorrect driver-valve electrical connection;
- electronic problems with the valve control driver;
- secondary fluid evaporator fan/pump malfunction;
- insufficient refrigerant in the refrigerant circuit;
- refrigerant leaks;
- lack of subcooling in the condenser;
- electrical/mechanical problems with the compressor;
- processing residues or moisture in the refrigerant circuit.

Note:

the valve unblock procedure is nonetheless performed in each of these cases, given that it does not cause mechanical or control problems. Therefore, also check these possible causes before replacing the valve.

7. PROTECTORS

Note: the HiTcond and reverse HiTcond protectors can be activated if EVD Evolution twin works as a single driver (see Appendix 2) or if programmable control is activated (see chap. on Control).

These are additional functions that are activated in specific situations that are potentially dangerous for the unit being controlled. They feature an integral action, that is, the action increases gradually when moving away from the activation threshold. They may add to or overlap (disabling) normal PID superheat control. By separating the management of these functions from PID control, the parameters can be set separately, allowing, for example, normal control that is less reactive yet much faster in responding when exceeding the activation limits of one of the protectors.

7.1 Protectors

There are 3 protectors:

- LowSH, low superheat;
- LOP, low evaporation temperature;
- MOP, high evaporation temperature;

The protectors have the following main features:

- activation threshold: depending on the operating conditions of the controlled unit, this is set in Service programming mode;
- integral time, which determines the intensity (if set to 0, the protector is disabled): set automatically based on the type of main control;
- alarm, with activation threshold (the same as the protector) and delay (if set to 0 disables the alarm signal).

Note: the alarm signal is independent from the effectiveness of the protector, and only signals that the corresponding threshold has been exceeded. If a protector is disabled (null integration time), the relative alarm signal is also disabled.

Each protector is affected by the proportional gain parameter (K) for the PID superheat control. The higher the value of K, the more intense the reaction of the protector will be.

Characteristics of the protectors

| Protection | Reaction | Reset |
|------------|------------------|------------|
| LowSH | Intense closing | Immediate |
| LOP | Intense opening | Immediate |
| MOP | Moderate closing | Controlled |

Tab. 7.a

Reaction: summary description of the type of action in controlling the valve.
Reset: summary description of the type of reset following the activation of the protector. Reset is controlled to avoid swings around the activation threshold or immediate reactivation of the protector.

LowSH (low superheat)

The protector is activated so as to prevent the return of liquid to the compressor due to excessively low superheat values.

| Parameter/description | Def. | Min. | Max. | UOM |
|---|------|-----------|--------------|--------|
| CONTROL | | | | |
| LowSH protection: threshold | 5 | -40 (-72) | SH set point | K (°F) |
| LowSH protection: integral time | 15 | 0 | 800 | s |
| ALARM CONFIGURATION | | | | |
| Low superheat alarm delay (LowSH) (0= alarm disabled) | 300 | 0 | 18000 | s |

Tab. 7.b

When the superheat value falls below the threshold, the system enters low superheat status, and the intensity with which the valve is closed is increased: the more the superheat falls below the threshold, the more intensely the valve will close. The LowSH threshold, must be less than or equal to the superheat set point. The low superheat integration time indicates the intensity of the action: the lower the value, the more intense the action.

The integral time is set automatically based on the type of main control.

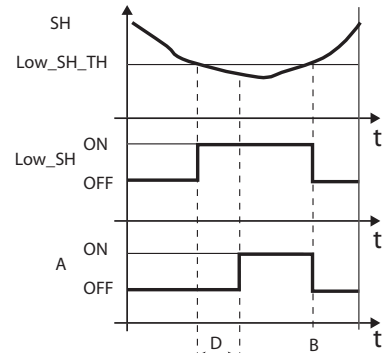

Fig. 7.a

Key:

| | | | |
|-----------|-----------------------------|---|-------------|
| SH | Superheat | A | Alarm |
| Low_SH_TH | Low_SH protection threshold | D | Alarm delay |
| Low_SH | Low_SH protection | t | Time |
| B | Automatic alarm reset | | |

LOP (low evaporation pressure)

LOP= Low Operating Pressure

The LOP protection threshold is applied as a saturated evaporation temperature value so that it can be easily compared against the technical specifications supplied by the manufacturers of the compressors. The protector is activated so as to prevent too low evaporation temperatures from stopping the compressor due to the activation of the low pressure switch. The protector is very useful in units with compressors on board (especially multi-stage), where when starting or increasing capacity the evaporation temperature tends to drop suddenly.

When the evaporation temperature falls below the low evaporation temperature threshold, the system enters LOP status and the intensity with which the valve is opened is increased. The further the temperature falls below the threshold, the more intensely the valve will open. The integral time indicates the intensity of the action: the lower the value, the more intense the action.

| Parameter/description | Def. | Min. | Max. | UOM |
|---|------|-----------|---------------------------|---------|
| CONTROL | | | | |
| LOP protection: threshold | -50 | -60 (-76) | MOP protection: threshold | °C (°F) |
| LOP protection: integral time | 0 | 0 | 800 | s |
| ALARM CONFIGURATION | | | | |
| Low evaporation temperature alarm delay (LOP) (0= alarm disabled) | 300 | 0 | 18000 | s |

Tab. 7.c

The integral time is set automatically based on the type of main control.



Note:

- the LOP threshold must be lower than the rated evaporation temperature of the unit, otherwise it would be activated unnecessarily, and greater than the calibration of the low pressure switch, otherwise it would be useless. As an initial approximation it can be set to a value exactly half-way between the two limits indicated;
- the protector has no purpose in multiplexed systems (showcases) where the evaporation is kept constant and the status of the individual electronic valve does not affect the pressure value;
- the LOP alarm can be used as an alarm to highlight refrigerant leaks by the circuit. A refrigerant leak in fact causes an abnormal lowering of the evaporation temperature that is proportional, in terms of speed and extent, to the amount of refrigerant dispersed.

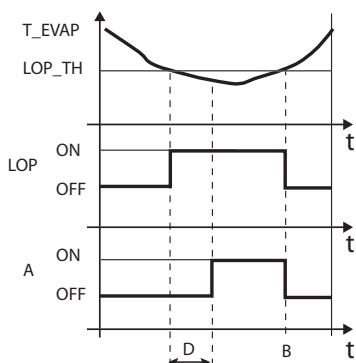

Fig. 7.b

Key:

| | | | |
|--------|--|-------|-------------|
| T_EVAP | Evaporation temperature | D | Alarm delay |
| LOP_TH | Low evaporation temperature protection threshold | ALARM | Alarm |
| LOP | LOP protection | t | Time |
| B | Automatic alarm reset | | |

MOP (high evaporation pressure)

MOP= Maximum Operating Pressure.

The MOP protection threshold is applied as a saturated evaporation temperature value so that it can be easily compared against the technical specifications supplied by the manufacturers of the compressors. The protector is activated so as to prevent too high evaporation temperatures from causing an excessive workload for the compressor, with consequent overheating of the motor and possible activation of the thermal protector. The protector is very useful in units with compressor on board if starting with a high refrigerant charge or when there are sudden variations in the load. The protector is also useful in multiplexed systems (showcases), as allows all the utilities to be enabled at the same time without causing problems of high pressure for the compressors. To reduce the evaporation temperature, the output of the refrigeration unit needs to be decreased. This can be done by controlled closing of the electronic valve, implying superheat is no longer controlled, and an increase in the superheat temperature. The protector will thus have a moderate reaction that tends to limit the increase in the evaporation temperature, keeping it below the activation threshold while trying to stop the superheat from increasing as much as possible. Normal operating conditions will not resume based on the activation of the protector, but rather on the reduction in the refrigerant charge that caused the increase in temperature. The system will therefore remain in the best operating conditions (a little below the threshold) until the load conditions change.

| Parameter/description | Def. | Min. | Max. | UOM |
|--|------|---------------------------|-----------|---------|
| CONTROL | | | | |
| MOP protection: threshold | 50 | LOP protection: threshold | 200 (392) | °C (°F) |
| MOP protection: integral time | 20 | 0 | 800 | s |
| ALARM CONFIGURATION | | | | |
| High evaporation temperature alarm delay (MOP) (0= alarm disabled) | 600 | 0 | 18000 | s |

Tab. 7.d

The integral time is set automatically based on the type of main control.

When the evaporation temperature rises above the MOP threshold, the system enters MOP status, superheat control is interrupted to allow the pressure to be controlled, and the valve closes slowly, trying to limit the evaporation temperature. As the action is integral, it depends directly on the difference between the evaporation temperature and the activation threshold. The more the evaporation temperature increases with reference to the MOP threshold, the more intensely the valve will close. The integral time indicates the intensity of the action: the lower the value, the more intense the action.

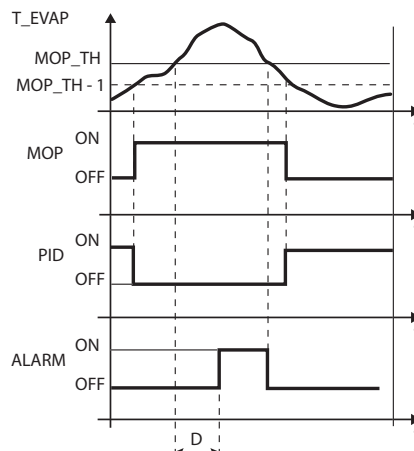

Fig. 7.c

Key:

| | | | |
|--------|-------------------------|--------|---------------|
| T_EVAP | Evaporation temperature | MOP_TH | MOP threshold |
| PID | PID superheat control | ALARM | Alarm |
| MOP | MOP protection | t | Time |
| D | Alarm delay | | |



Important: the MOP threshold must be greater than the rated evaporation temperature of the unit, otherwise it would be activated unnecessarily. The MOP threshold is often supplied by the manufacturer of the compressor. It is usually between 10°C and 15 °C.

If the closing of the valve also causes an excessive increase in the suction temperature (S2) above the set threshold – only set via supervisor (PlantVisor, pCO, VPM), not on the display - the valve will be stopped to prevent overheating the compressor windings, awaiting a reduction in the refrigerant charge. If the MOP protection function is disabled by setting the integral time to zero, the maximum suction temperature control is also deactivated.

| Parameter/description | Def. | Min. | Max. | UOM |
|---|------|-----------|-----------|--------|
| CONTROL | | | | |
| MOP protection: suction temperature threshold | 30 | -60 (-72) | 200 (392) | °C(°F) |

Tab. 7.e

At the end of the MOP protection function, superheat control restarts in a controlled manner to prevent the evaporation temperature from exceeding the threshold again..

| user * | Parameter/description | Def. | Min. | Max. | UOM | Type ** | CAREL SVP | Modbus® | Note | | | | | | | | | | | | | | | | | | | | | | | | | | | | |
|-----------------------------|---|--------------------------------|----------------------------|-----------------------|--------------------------|-----------------------------|-----------------------------------|-------------------|-------------------|-------------------|------------------|----------------------|------------------|-------------------|--------------------|-----------------|----------------------------|--|--------------------------|--|----------------------------|--|--------------------------|--|--------------------------|--|----------------------------|--|-------------------------------|-----------------------------|---|---|---|---|----|-----|----|
| A | <p>Main control:</p> <p>0= user defined; 1= Multiplexed showcase/cold room 2= Showcase/cold room with compressor on board 3= "Perturbed" showcase/cold room 4= Showcase/cold room with sub-critical CO₂ 5= R404A condenser for sub-critical CO₂ 6= Air-conditioner/chiller with plate heat exchanger 7= Air-conditioner/chiller with tube bundle heat exchanger 8= Air-conditioner/chiller with finned coil heat exchanger 9= Air-conditioner/chiller with variable cooling capacity 10= "Perturbed" air-conditioner/chiller 11= EPR back pressure 12= Hot gas bypass by pressure 13= Hot gas bypass by temperature 14= Transcritical CO₂ gas cooler 15= Analogue positioner (4 to 20 mA) 16= Analogue positioner (0 to 10 V) 17= Air-conditioner/chiller or showcase/cold room with adaptive control 18= Air-conditioner/chiller with Digital Scroll compressor (*) 19= AC or chiller with BLDC scroll compressor (CANNOT BE SELECTED) 20= superheat regulation with 2 temperature probes (CANNOT BE SELECTED) 21= I/O expander for pCO (**) 22= Programmable SH regulation 23= Programmable special regulation 24= Programmable positioner 25= Evaporator liquid level regulation with CAREL sensor 26= Condenser liquid level regulation with CAREL sensor (*) only for controls for CAREL valves (**) common parameter between driver A and driver B</p> | Multiplexed showcase/cold room | - | - | - | I | 15 | 142 | - | | | | | | | | | | | | | | | | | | | | | | | | | | | | |
| A | <p>Probe S2:</p> <table border="1"> <tr> <td>0= user defined</td> <td>1= NTC CAREL</td> </tr> <tr> <td>2= CAREL NTC- HT high</td> <td>3= combined NTC SPKP**T0</td> </tr> <tr> <td>4= 0 to 10V external signal</td> <td>5= NTC - LT CAREL low temperature</td> </tr> </table> | 0= user defined | 1= NTC CAREL | 2= CAREL NTC- HT high | 3= combined NTC SPKP**T0 | 4= 0 to 10V external signal | 5= NTC - LT CAREL low temperature | CAREL NTC | - | - | - | I | 17 | 144 | CO | | | | | | | | | | | | | | | | | | | | | | |
| 0= user defined | 1= NTC CAREL | | | | | | | | | | | | | | | | | | | | | | | | | | | | | | | | | | | | |
| 2= CAREL NTC- HT high | 3= combined NTC SPKP**T0 | | | | | | | | | | | | | | | | | | | | | | | | | | | | | | | | | | | | |
| 4= 0 to 10V external signal | 5= NTC - LT CAREL low temperature | | | | | | | | | | | | | | | | | | | | | | | | | | | | | | | | | | | | |
| A | <p>Auxiliary control:</p> <p>0= user defined 1= Disabled 2= high condensing temperature protection on S3 probe 3= modulating thermostat on S4 probe 4= backup probes on S3 and S4 5, 6, 7 = Reserved 8= Subcooling measurement 9= Inverse high condensation temperature protection on S3 probe 10= Reserved</p> | - | - | - | - | I | 18 | 145 | CO | | | | | | | | | | | | | | | | | | | | | | | | | | | | |
| A | <p>Probe S3:</p> <p>0= user defined</p> <table border="1"> <tr> <td>Ratiometric (OUT=0 to 5 V)</td> <td>Electronic (OUT=4 - 20 mA)</td> </tr> <tr> <td>1= -1 to 4.2 barg</td> <td>8= -0.5 to 7 barg</td> </tr> <tr> <td>2=-0.4...9.3 barg</td> <td>9= 0 to 10 barg</td> </tr> <tr> <td>3= -1 to 9.3 barg</td> <td>10= 0 to 18.2 bar</td> </tr> <tr> <td>4= 0 to 17.3 barg</td> <td>11= 0 to 25 barg</td> </tr> <tr> <td>5= 0.85 to 34.2 barg</td> <td>12= 0 to 30 barg</td> </tr> <tr> <td>6= 0 to 34.5 barg</td> <td>13= 0 to 44.8 barg</td> </tr> <tr> <td>7= 0 to 45 barg</td> <td>14= remote, -0.5 to 7 barg</td> </tr> <tr> <td></td> <td>15= remote, 0 to 10 barg</td> </tr> <tr> <td></td> <td>16= remote, 0 to 18.2 barg</td> </tr> <tr> <td></td> <td>17= remote, 0 to 25 barg</td> </tr> <tr> <td></td> <td>18= remote, 0 to 30 barg</td> </tr> <tr> <td></td> <td>19= remote, 0 to 44.8 barg</td> </tr> <tr> <td></td> <td>20= 4 to 20mA external signal</td> </tr> </table> <p>21= -1 to 12.8 barg 22= 0 to 20.7 barg 23= 1.86 to 43.0 barg) 24= CAREL liquid level 25 = 0...60,0 barg 26 = 0...90,0 barg 27 = external signal 0...5 V</p> | Ratiometric (OUT=0 to 5 V) | Electronic (OUT=4 - 20 mA) | 1= -1 to 4.2 barg | 8= -0.5 to 7 barg | 2=-0.4...9.3 barg | 9= 0 to 10 barg | 3= -1 to 9.3 barg | 10= 0 to 18.2 bar | 4= 0 to 17.3 barg | 11= 0 to 25 barg | 5= 0.85 to 34.2 barg | 12= 0 to 30 barg | 6= 0 to 34.5 barg | 13= 0 to 44.8 barg | 7= 0 to 45 barg | 14= remote, -0.5 to 7 barg | | 15= remote, 0 to 10 barg | | 16= remote, 0 to 18.2 barg | | 17= remote, 0 to 25 barg | | 18= remote, 0 to 30 barg | | 19= remote, 0 to 44.8 barg | | 20= 4 to 20mA external signal | Ratiometric: -1 to 9.3 barg | - | - | - | I | 19 | 146 | CO |
| Ratiometric (OUT=0 to 5 V) | Electronic (OUT=4 - 20 mA) | | | | | | | | | | | | | | | | | | | | | | | | | | | | | | | | | | | | |
| 1= -1 to 4.2 barg | 8= -0.5 to 7 barg | | | | | | | | | | | | | | | | | | | | | | | | | | | | | | | | | | | | |
| 2=-0.4...9.3 barg | 9= 0 to 10 barg | | | | | | | | | | | | | | | | | | | | | | | | | | | | | | | | | | | | |
| 3= -1 to 9.3 barg | 10= 0 to 18.2 bar | | | | | | | | | | | | | | | | | | | | | | | | | | | | | | | | | | | | |
| 4= 0 to 17.3 barg | 11= 0 to 25 barg | | | | | | | | | | | | | | | | | | | | | | | | | | | | | | | | | | | | |
| 5= 0.85 to 34.2 barg | 12= 0 to 30 barg | | | | | | | | | | | | | | | | | | | | | | | | | | | | | | | | | | | | |
| 6= 0 to 34.5 barg | 13= 0 to 44.8 barg | | | | | | | | | | | | | | | | | | | | | | | | | | | | | | | | | | | | |
| 7= 0 to 45 barg | 14= remote, -0.5 to 7 barg | | | | | | | | | | | | | | | | | | | | | | | | | | | | | | | | | | | | |
| | 15= remote, 0 to 10 barg | | | | | | | | | | | | | | | | | | | | | | | | | | | | | | | | | | | | |
| | 16= remote, 0 to 18.2 barg | | | | | | | | | | | | | | | | | | | | | | | | | | | | | | | | | | | | |
| | 17= remote, 0 to 25 barg | | | | | | | | | | | | | | | | | | | | | | | | | | | | | | | | | | | | |
| | 18= remote, 0 to 30 barg | | | | | | | | | | | | | | | | | | | | | | | | | | | | | | | | | | | | |
| | 19= remote, 0 to 44.8 barg | | | | | | | | | | | | | | | | | | | | | | | | | | | | | | | | | | | | |
| | 20= 4 to 20mA external signal | | | | | | | | | | | | | | | | | | | | | | | | | | | | | | | | | | | | |

| user* | Parameter/description | Def. | Min. | Max. | UOM | Type** | CAREL SVP | Modbus® | Note |
|-------|---|---|------|------|-----|--------|-----------|---------|------|
| A | Relay configuration: 1= Disabled 2= Alarm relay (open when alarm active) 3= Solenoid valve relay (open in standby) 4= Valve + alarm relay (open in standby and control alarms) 5= Reversed alarm relay (closed in case of alarm) 6= Valve status relay (open if valve is closed) 7= Direct command 8= Faulty closure alarm relay (opened if alarm) 9= Reverse faulty closure alarm relay (closed if alarm) | Alarm relay | - | - | - | I | 12 | 139 | - |
| A | Probe S4: 0= User defined 1= CAREL NTC 2= CAREL NTC-HT high temperature 3= Combined NTC SPKP**T0 4= --- 5= NTC-LT CAREL low temperature | CAREL NTC | - | - | - | I | 20 | 147 | - |
| A | DI2 Configuration: 1= Disabled 2= Valve regulation optimization after defrost 3= Discharged battery alarm management 4= Valve forced open (at 100%) 5= Regulation start/stop 6= Regulation backup 7= Regulation security | Regulation start/stop (tLAN-RS485) / Regulation backup (pLAN) | - | - | - | I | 10 | 137 | CO |
| C | Variable 1 on display: 1= Valve opening 2= Valve position 3= Current cooling capacity 4= Set point control 5= Superheat 6= Suction temperature 7= Evaporation temperature 8= Evaporation pressure 9= Condensing temperature 10= Condensing pressure 11= Modulating thermostat temperature(*) 12= EPR pressure 13= Hot gas bypass pressure 14= Hot gas bypass temperature 15= CO ₂ gas cooler outlet temperature 16= CO ₂ gas cooler outlet pressure 17= CO ₂ gas cooler pressure set point 18= Probe S1 reading 19= Probe S2 reading 20= Probe S3 reading 21= Probe S4 reading 22= 4 to 20 mA input 23= 0 to 10 V input (*) CANNOT BE SELECTED | Superheat | - | - | - | I | 45 | 172 | - |
| C | Variable 2 on display (see variable 1 on display) | Valve opening | - | - | - | I | 46 | 173 | - |
| C | Probe S1 alarm management: 1= No action 2= Forced valve closing 3= Valve in fixed position 4= Use backup probe S3 (*) (*) CANNOT BE SELECTED | Valve in fixed position | - | - | - | I | 24 | 151 | CO |
| C | Probe S2 alarm management: 1= No action 2= Forced valve closing 3= Valve in fixed position 4= Use backup probe S4 (*) (*) CANNOT BE SELECTED | Valve in fixed position | - | - | - | I | 25 | 152 | CO |
| C | Probe S3 alarm management: 1= No action 2= Forced valve closing 3= Valve in fixed position | No action | - | - | - | I | 26 | 153 | CO |
| C | Probe S4 alarm management: 1= No action 2= Forced valve closing 3= Valve in fixed position | No action | - | - | - | I | 27 | 154 | CO |
| C | Unit of measure: 1= °C/K/barg; 2= °F/psig | °C/K/barg | - | - | - | I | 21 | 148 | CO |

| user * | Parameter/description | Def. | Min. | Max. | UOM | Type ** | CAREL SVP | Modbus® | Note |
|----------------|---|---|-------------------------------------|-------------------------------------|-------------------|---------|-----------|---------|------|
| A | DI1 configuration 1= Disabled 2= Valve regulation optimization after defrost 3= Discharged battery alarm management 4= Valve forced open (at 100%) 5= Regulation start/stop 6= Regulation backup 7= Regulation security | Regulation start/stop (tLAN-RS485) / Regulation backup (pLAN) | - | - | - | I | 85 | 212 | CO |
| C | Language: Italiano; English | Italiano | - | - | - | | | | CO |
| C | Auxiliary refrigerant -1= user defined; 0 = same as main regulation 1= R22 2= R134a 3= R404A 4= R407C 5= R410A 6= R507A 7= R290 8= R600 9= R600a 10= R717 11= R744 12= R728 13= R1270 14= R417A 15= R422D 16= R413A 17= R422A 18= R423A 19= R407A 20= R427A 21= R245FA 22= R407F 23=R32 24=HTR01 25= HTR02 26=R23 27 = R1234yf 28 = R1234ze 29 = R455A 30 = R170 31 = R442A 32 = R447A 33 = R448A 34 = R449A 35 = R450A 36 = R452A 37 = R508B 38 = R452B 39 = R513A 40 = R454B 41 = R458A | R404A | - | - | - | I | 96 | 223 | CO |
| PROBES | | | | | | | | | |
| C | S1: calibration offset | 0 | -60(-870), -60 | 60(870), 60 | barg (psig) mA | A | 34 | 33 | CO |
| C | S1: calibration gain, 4 to 20 mA | 1 | -20 | 20 | - | A | 36 | 35 | CO |
| C | Pressure S1: MINIMUM value | -1 | -20 (-290) | Pressure S1: MAXIMUM value | barg (psig) | A | 32 | 31 | CO |
| C | Pressure S1: MAXIMUM value | 9,3 | Pressure S1: MINIMUM value | 200 (2900) | barg (psig) | A | 30 | 29 | CO |
| C | Pressure S1: MINIMUM alarm value | -1 | -20 (-290) | Pressure S1: MAXIMUM alarm value | barg (psig) | A | 39 | 38 | CO |
| C | Pressure S1: MAXIMUM alarm value | 9,3 | Pressure S1: MINIMUM alarm value | 200 (2900) | barg (psig) | A | 37 | 36 | CO |
| C | S2: calibration offset | 0 | -20 (-36), -20 | 20 (36), 20 | °C (°F), volt | A | 41 | 40 | CO |
| C | S2: calibration gain, 0 to 10 V | 1 | -20 | 20 | - | A | 43 | 42 | CO |
| C | Temperature S2: MINIMUM alarm value | -50 | -85(-121) | Temperature S2: MAXIMUM alarm value | °C (°F) | A | 46 | 45 | CO |
| C | Temperature S2: MAXIMUM alarm value | 105 | Temperature S2: MINIMUM alarm value | 200 (392) | °C (°F) | A | 44 | 43 | CO |
| C | S3: calibration offset | 0 | -60 (-870) | 60 (870) | barg (psig) | A | 35 | 34 | CO |
| C | S3: calibration gain, 4 to 20 mA | 1 | -20 | 20 | - | A | 82 | 81 | CO |
| C | Pressure S3 : MINIMUM value | -1 | -20 (-290) | Pressure S3: MAXIMUM value | barg (psig) | A | 33 | 32 | CO |
| C | Pressure S3: MAXIMUM value | 9,3 | Pressure S3: MINIMUM value | 200 (2900) | barg (psig) | A | 31 | 30 | CO |
| C | Pressure S3: MINIMUM alarm value | -1 | -20 (-290) | Pressure S3: MAXIMUM alarm value | barg (psig) | A | 40 | 39 | CO |
| C | Pressure S3: MAXIMUM alarm value | 9,3 | Pressure S3: MINIMUM alarm value | 200 (2900) | barg (psig) | A | 38 | 37 | CO |
| C | S4: calibration offset | 0 | -20 (-36) | 20 (36) | °C (°F) | A | 42 | 41 | CO |
| C | Temperature S4: MINIMUM alarm value | -50 | -85(-121) | Temperature S4: MAXIMUM alarm value | °C (°F) | A | 47 | 46 | CO |
| C | Temperature S4: MAXIMUM alarm value | 105 | Temperature S4: MINIMUM alarm value | 200 (392) | °C (°F) | A | 45 | 44 | CO |
| C | Maximum difference S1/S3 (pressure) | 0 | 0 | 200(2900) | bar(psig) | A | 114 | 113 | CO |
| C | Maximum difference S2/S4 (temperature) | 0 | 0 | 180(324) | °C (°F) | A | 115 | 114 | CO |
| C | Alarm delay S1 | 0 | 0 | 240 | s | I | 131 | 258 | CO |
| C | Alarm delay S2 | 0 | 0 | 240 | s | I | 132 | 259 | CO |
| C | Alarm delay S3 | 0 | 0 | 240 | s | I | 133 | 260 | CO |
| C | Alarm delay S4 | 0 | 0 | 240 | s | I | 134 | 261 | CO |
| C | Enable S1 | 0 | 0 | 1 | - | D | 16 | 15 | CO |
| C | Enable S2 | 0 | 0 | 1 | - | D | 17 | 16 | CO |
| C | Enable S3 | 0 | 0 | 1 | - | D | 18 | 17 | CO |
| C | Enable S4 | 0 | 0 | 1 | - | D | 19 | 18 | CO |
| CONTROL | | | | | | | | | |

| user* | Parameter/description | Def. | Min. | Max. | UOM | Type** | CAREL SVP | Modbus® | Note |
|----------------|---|-------------|---------------------------|---------------------------|-------------|--------|-----------|---------|------|
| A | Superheat set point | 11 | LowSH: threshold | 180 (324) | K (°F) | A | 50 | 49 | - |
| A | Valve opening at start-up (evaporator/valve capacity ratio) | 50 | 0 | 100 | % | I | 37 | 164 | - |
| C | Valve open in stand-by (0= disabled= valve closed; 1=enabled = valve open according to parameter "Valve position in stand-by") | 0 | 0 | 1 | - | D | 23 | 22 | - |
| C | Valve position in stand-by 0 = 25% 1...100% = % opening | 0 | 0 | 100 | % | I | 91 | 218 | - |
| C | start-up delay after defrost | 10 | 0 | 60 | min | I | 40 | 167 | - |
| A | Pre-position time | 6 | 0 | 18000 | s | I | 90 | 217 | - |
| A | Hot gas bypass temperature set point | 10 | -85(-121) | 200 (392) | °C (°F) | A | 28 | 27 | - |
| A | Hot gas bypass pressure set point | 3 | -20 (-290) | 200 (2900) | barg (psig) | A | 62 | 61 | - |
| A | EPR pressure set point | 3.5 | -20 (-290) | 200 (2900) | barg (psig) | A | 29 | 28 | - |
| C | PID: proportional gain | 15 | 0 | 800 | - | A | 48 | 47 | - |
| C | PID: integral time | 150 | 0 | 1000 | s | I | 38 | 165 | - |
| C | PID: derivative time | 5 | 0 | 800 | s | A | 49 | 48 | - |
| A | LowSH protection: threshold | 5 | -40 (-72) | SH set point | K (°F) | A | 56 | 55 | - |
| C | LowSH protection: integral time | 15 | 0 | 800 | s | A | 55 | 54 | - |
| A | LOP protection: threshold | -50 | -85(-121) | MOP protection: threshold | °C (°F) | A | 52 | 51 | - |
| C | LOP protection: integral time | 0 | 0 | 800 | s | A | 51 | 50 | - |
| A | MOP protection: threshold | 50 | LOP protection: threshold | 200 (392) | °C (°F) | A | 54 | 53 | - |
| C | MOP protection: integral time | 20 | 0 | 800 | s | A | 53 | 52 | - |
| A | Enable manual valve positioning | 0 | 0 | 1 | - | D | 24 | 23 | - |
| A | Manual valve position | 0 | 0 | 9999 | step | I | 39 | 166 | - |
| C | Discharge superheat setpoint (CANNOT BE SELECTED) | 35 | -40(-72) | 180 (324) | K (F°) | A | 100 | 99 | - |
| C | Discharge temperature setpoint (CANNOT BE SELECTED) | 105 | -85(-121) | 200 (392) | °C (°F) | A | 101 | 100 | - |
| C | Liquid level set point | 50 | 0 | 100 | % | A | 119 | 118 | - |
| SPECIAL | | | | | | | | | |
| A | HiTcond: threshold - SELECT WITH PROG. CONT. | 80 | -85(-121) | 200 (392) | °C (°F) | A | 58 | 57 | - |
| C | HiTcond: integral time - SELECT WITH PROG. CONT. | 20 | 0 | 800 | s | A | 57 | 56 | - |
| A | Modulating thermostat: set point - SELECT WITH PROG. CONT. | 0 | -85(-121) | 200 (392) | °C (°F) | A | 61 | 60 | - |
| A | Modulating thermostat: differential - SELECT WITH PROG. CONT. | 0.1 | 0.1 (0.2) | 100 (180) | °C (°F) | A | 60 | 59 | - |
| C | Mod. thermostat: SH set point offset - SELECT WITH PROG. CONT. | 0 | 0 (0) | 100 (180) | K (°F) | A | 59 | 58 | - |
| C | Coefficient 'A' for CO ₂ control | 3.3 | -100 | 800 | - | A | 63 | 62 | - |
| C | Coefficient 'B' for CO ₂ control | -22.7 | -100 | 800 | - | A | 64 | 63 | - |
| C | Force manual tuning 0=no; 1= yes | 0 | 0 | 1 | - | D | 39 | 38 | - |
| C | Tuning method 0 to 100= automatic selection 101 to 141= manual selection 142 to 254= not allowed 255= PID parameters model identified | 0 | 0 | 255 | - | I | 79 | 206 | - |
| C | Impostazioni di rete | 2 | 0 | 30 | - | I | 74 | 201 | CO |
| | Parity | Bit di stop | Baud rate | | | | | | |
| | 0 | no parity | 2 stop bits | 4800 bps | | | | | |
| | 1 | no parity | 2 stop bits | 9600 bps | | | | | |
| | 2 | no parity | 2 stop bits | 19200 bps | | | | | |
| | 4 | no parity | 1 stop bit | 4800 bps | | | | | |
| | 5 | no parity | 1 stop bit | 9600 bps | | | | | |
| | 6 | no parity | 1 stop bit | 19200 bps | | | | | |
| | 16 | even | 2 stop bits | 4800 bps | | | | | |
| | 17 | even | 2 stop bits | 9600 bps | | | | | |
| | 18 | even | 2 stop bits | 19200 bps | | | | | |
| | 20 | even | 1 stop bit | 4800 bps | | | | | |
| | 21 | even | 1 stop bit | 9600 bps | | | | | |
| | 22 | even | 1 stop bit | 19200 bps | | | | | |
| | 24 | odd | 2 stop bits | 4800 bps | | | | | |
| | 25 | odd | 2 stop bits | 9600 bps | | | | | |
| | 26 | odd | 2 stop bits | 19200 bps | | | | | |
| | 28 | odd | 1 stop bit | 4800 bps | | | | | |
| | 29 | odd | 1 stop bit | 9600 bps | | | | | |
| | 30 | odd | 1 stop bit | 19200 bps | | | | | |
| A | Power supply mode 0= 24 Vac; 1= 24 Vdc | 0 | 0 | 1 | - | D | 47 | 46 | CO |
| C | Enable mode single on twin (parameter disabled) 0= Twin; 1= Single | 0 | 0 | 1 | - | D | 58 | 57 | CO |
| C | Stop manual positioning if net error 0 = Normal operation; 1 = Stop | 0 | 0 | 1 | - | D | 59 | 58 | CO |
| C | Programmable regulation configuration | 0 | 0 | 32767 | - | I | 101 | 228 | |
| C | Programmable regulation input | 0 | 0 | 32767 | - | I | 102 | 229 | |
| C | Programmable SH regulation options | 0 | 0 | 32767 | - | I | 103 | 230 | |
| C | Programmable regulation set point | 0 | -800(-1233) | 800(1233) | - | A | 112 | 111 | |

| user* | Parameter/description | Def. | Min. | Max. | UOM | Type** | CAREL SVP | Modbus® | Note |
|----------------------------|--|--------|------------|-----------|---------|--------|-----------|---------|------|
| C | CUSTOMIZED REFRIGERANT | | | | | | | | |
| | Dew a high | -288 | -32768 | 32767 | - | I | 107 | 234 | |
| | Dew a low | -15818 | -32768 | 32767 | - | I | 108 | 235 | |
| | Dew b high | -14829 | -32768 | 32767 | - | I | 109 | 236 | |
| | Dew b low | 16804 | -32768 | 32767 | - | I | 110 | 237 | |
| | Dew c high | -11664 | -32768 | 32767 | - | I | 111 | 238 | |
| | Dew c low | 16416 | -32768 | 32767 | - | I | 112 | 239 | |
| | Dew d high | -23322 | -32768 | 32767 | - | I | 113 | 240 | |
| | Dew d low | -16959 | -32768 | 32767 | - | I | 114 | 241 | |
| | Dew e high | -16378 | -32768 | 32767 | - | I | 115 | 242 | |
| | Dew e low | 15910 | -32768 | 32767 | - | I | 116 | 243 | |
| | Dew f high | -2927 | -32768 | 32767 | - | I | 117 | 244 | |
| | Dew f low | -17239 | -32768 | 32767 | - | I | 118 | 245 | |
| | Bubble a high | -433 | -32768 | 32767 | - | I | 119 | 246 | |
| | Bubble a low | -15815 | -32768 | 32767 | - | I | 120 | 247 | |
| | Bubble b high | -15615 | -32768 | 32767 | - | I | 121 | 248 | |
| | Bubble b low | 16805 | -32768 | 32767 | - | I | 122 | 249 | |
| | Bubble c high | 30803 | -32768 | 32767 | - | I | 123 | 250 | |
| | Bubble c low | 16416 | -32768 | 32767 | - | I | 124 | 251 | |
| | Bubble d high | -21587 | -32768 | 32767 | - | I | 125 | 252 | |
| | Bubble d low | -16995 | -32768 | 32767 | - | I | 126 | 253 | |
| | Bubble e high | -24698 | -32768 | 32767 | - | I | 127 | 254 | |
| | Bubble e low | 15900 | -32768 | 32767 | - | I | 128 | 255 | |
| | Bubble f high | 10057 | -32768 | 32767 | - | I | 129 | 256 | |
| | Bubble f low | -17253 | -32768 | 32767 | - | I | 130 | 257 | |
| C | Faulty closure alarm status 0/1=no/yes | 0 | 0 | 1 | - | D | 49 | 48 | |
| C | Battery charge delay | 0 | 0 | 250 | min | I | 135 | 262 | CO |
| ALARM CONFIGURATION | | | | | | | | | |
| C | Low superheat alarm delay (LowSH) (0= alarm disabled) | 300 | 0 | 18000 | s | I | 43 | 170 | - |
| C | Low evaporation temperature alarm delay (LOP) (0= alarm disabled) | 300 | 0 | 18000 | s | I | 41 | 168 | - |
| C | High evaporation temperature alarm delay (MOP) (0= alarm disabled) | 600 | 0 | 18000 | s | I | 42 | 169 | - |
| C | High condensing temperature alarm delay (HiTcond) SELECT WITH PROG. CONT. | 600 | 0 | 18000 | s | I | 44 | 171 | CO |
| C | Low suction temperature alarm threshold | -50 | -85 (-121) | 200 (392) | °C (°F) | A | 26 | 25 | - |
| C | Low suction temperature alarm delay (0= alarm disabled) | 300 | 0 | 18000 | s | I | 9 | 136 | - |
| VALVE | | | | | | | | | |
| C | EEV minimum steps | 50 | 0 | 9999 | step | I | 30 | 157 | - |
| C | EEV maximum steps | 480 | 0 | 9999 | step | I | 31 | 158 | - |
| C | EEV closing steps | 500 | 0 | 9999 | step | I | 36 | 163 | - |
| C | EEV rated speed | 50 | 1 | 2000 | step/s | I | 32 | 159 | - |
| C | EEV rated current | 450 | 0 | 800 | mA | I | 33 | 160 | - |
| C | EEV holding current | 100 | 0 | 250 | mA | I | 35 | 162 | - |
| C | EEV duty cycle | 30 | 1 | 100 | % | I | 34 | 161 | - |
| C | Synchronise position in opening | 1 | 0 | 1 | - | D | 20 | 19 | - |
| C | Synchronise position in closing | 1 | 0 | 1 | - | D | 21 | 20 | - |

Tab. 8.a

* User level: A= Service (installer), C= manufacturer.

** Type of variable: A= Analogue; D= Digital; I= Integer

CO= parameter settable from driver A or from driver B

8.2 Table of parameters, driver B

| user * | Parameter/description | Def. | Min. | Max. | UOM | Type ** | CAREL SVP | Modbus® | Note | |
|----------------------|--|--------------------------------|------|------|-----|---------|-----------|---------|------|---|
| CONFIGURATION | | | | | | | | | | |
| A | Network address | pLAN: 30 altri: 198 | 1 | 207 | - | I | 11 | 138 | CO | |
| A | Refrigerant: 0= User defined; 1= R22 2= R134a 3= R404A 4= R407C 5= R410A 6= R507A 7= R290 8= R600 9= R600a 10= R717 11= R744 12= R728 13= R1270 14= R417A 15= R422D 16= R413A 17= R422A 18= R423A 19= R407A 20= R427A 21= R245FA 22= R407F 23=R32 24=HTR01 25= HTR02 26=R23 27 = R1234yf 28 = R1234ze 29 = R455A 30 = R170 31 = R442A 32 = R447A 33 = R448A 34 = R449A 35 = R450A 36 = R452A 37 = R508B 38 = R452B 39 = R513A 40 = R454B 41 = R458A | R404A | - | - | - | - | I | 55 | 182 | - |
| A | Valve: 0= user defined 13= Sporlan SEH 175 1= CAREL E ^V 14= Danfoss ETS 12.5-25B 2= Alco EX4 15= Danfoss ETS 50B 3= Alco EX5 16= Danfoss ETS 100B 4= Alco EX6 17= Danfoss ETS 250 5= Alco EX7 18= Danfoss ETS 400 6= Alco EX8 330Hz recommend 19= Two E ^V CAREL connected CAREL together 7= Alco EX8 500Hz specific Alco 20= Sporlan SER(I)G,J,K 8= Sporlan SEI 0.5-11 21= Danfoss CCM 10-20-30 9= Sporlan SER 1.5-20 22= Danfoss CCM 40 10= Sporlan SEI 30 23= Danfoss CCMT 2-4-8 11= Sporlan SEI 50 24= Disabled 12= Sporlan SEH 100 | CAREL E ^V | - | - | - | I | 54 | 181 | | |
| A | Probe S1: 0= User defined; Ratiometric (OUT=0 to 5 V) Electronic (OUT=4 - 20 mA) 1= -1 to 4.2 barg 8= -0.5 to 7 barg 2=-0.4...9.3 barg 9= 0 to 10 barg 3= -1 to 9.3 barg 10= 0 to 18.2 barg 4= 0 to 17.3 barg 11= 0 to 25 barg 5= 0.85 to 34.2 barg 12= 0 to 30 barg 6= 0 to 34.5 barg 13= 0 to 44.8 barg 7= 0 to 45 barg 14= remote, -0.5 to 7 barg 15= remote, 0 to 10 barg 16= remote, 0 to 18.2 barg 17= remote, 0 to 25 barg 18= remote, 0 to 30 barg 19= remote, 0 to 44.8 barg 20= 4 to 20mA external signal 21= -1 to 12.8 barg 22= 0 to 20.7 barg 23= 1.86 to 43.0 barg 24= CAREL liquid level 25= 0..60,0 barg 26= 0..90,0 barg 27 = external signal 0...5 V | Ratiometric: -1 to 9.3 barg | - | - | - | I | 16 | 143 | CO | |

| user * | Parameter/description | Def. | Min. | Max. | UOM | Type ** | CAREL SVP | Modbus® | Note | | | | | | | | | | | | | | | | | | | | | | | | | | | | | | | | | | | | | | | | | | | | | | | | | | | | | | | | | | | | | | | |
|-----------------------------|--|--------------------------------|----------------------------|----------------------------|--------------------------|-----------------------------|-----------------------------------|--------------------|-----------------|---|-------------------|-------------------|----|-------------------|------------------|--|----------------------|------------------|--|-------------------|--------------------|--|-----------------|----------------------------|--|--|--------------------------|--|--|----------------------------|--|--|--------------------------|--|--|--------------------------|--|--|----------------------------|--|--|-------------------------------|--|---------------------|--|--|--------------------|--|--|-----------------------|--|--|------------------------|--|--|------------------|--|--|------------------|--|--|-----------------------------|--|--|-----------------------------|---|---|---|---|----|-----|----|
| A | <p>Main control:</p> <p>1= Multiplexed showcase/cold room 2= Showcase/cold room with compressor on board 3= "Perturbed" showcase/cold room 4= Showcase/cold room with sub-critical CO₂ 5= R404A condenser for sub-critical CO₂ 6= Air-conditioner/chiller with plate heat exchanger 7= Air-conditioner/chiller with tube bundle heat exchanger 8= Air-conditioner/chiller with finned coil heat exchanger 9= Air-conditioner/chiller with variable cooling capacity 10= "Perturbed" air-conditioner/chiller 11= EPR back pressure 12= Hot gas bypass by pressure 13= Hot gas bypass by temperature 14= Transcritical CO₂ gas cooler 15= Analogue positioner (4 to 20 mA) 16= Analogue positioner (0 to 10 V) 17= Air-conditioner/chiller or showcase/cold room with adaptive control 18= Air-conditioner/chiller with Digital Scroll compressor (*) 19= AC or chiller with BLDC scroll compressor (CANNOT BE SELECTED) 20= superheat regulation with 2 temperature probes (CANNOT BE SELECTED) 21= I/O expander for pCO (**) 22= Programmable SH regulation 23= Programmable special regulation 24= Programmable positioner 25= Evaporator liquid level regulation with CAREL sensor 26= Condenser liquid level regulation with CAREL sensor (*)= control only settable on driver A, however corresponds to the entire controller</p> | Multiplexed showcase/cold room | - | - | - | I | 56 | 183 | - | | | | | | | | | | | | | | | | | | | | | | | | | | | | | | | | | | | | | | | | | | | | | | | | | | | | | | | | | | | | | | | |
| A | <p>Probe S2:</p> <table border="1"> <tr> <td>0= user defined</td> <td>1= CAREL NTC</td> </tr> <tr> <td>2= CAREL NTC-HT high temp.</td> <td>3= combined NTC SPKP**T0</td> </tr> <tr> <td>4= 0 to 10V external signal</td> <td>5= NTC - LT CAREL low temperature</td> </tr> </table> | 0= user defined | 1= CAREL NTC | 2= CAREL NTC-HT high temp. | 3= combined NTC SPKP**T0 | 4= 0 to 10V external signal | 5= NTC - LT CAREL low temperature | CAREL NTC | - | - | - | I | 17 | 144 | CO | | | | | | | | | | | | | | | | | | | | | | | | | | | | | | | | | | | | | | | | | | | | | | | | | | | | | | | | | |
| 0= user defined | 1= CAREL NTC | | | | | | | | | | | | | | | | | | | | | | | | | | | | | | | | | | | | | | | | | | | | | | | | | | | | | | | | | | | | | | | | | | | | | | | |
| 2= CAREL NTC-HT high temp. | 3= combined NTC SPKP**T0 | | | | | | | | | | | | | | | | | | | | | | | | | | | | | | | | | | | | | | | | | | | | | | | | | | | | | | | | | | | | | | | | | | | | | | | |
| 4= 0 to 10V external signal | 5= NTC - LT CAREL low temperature | | | | | | | | | | | | | | | | | | | | | | | | | | | | | | | | | | | | | | | | | | | | | | | | | | | | | | | | | | | | | | | | | | | | | | | |
| A | <p>Auxiliary control:</p> <p>0= user defined 1= Disabled 2= high condensing temperature protection on S3 probe 3= modulating thermostat on S4 probe 4= backup probes on S3 and S4 5, 6, 7 = Reserved 8= Subcooling measurement 9= Inverse high condensation temperature protection on S3 probe 10= Reserved</p> | - | - | - | - | I | 18 | 145 | CO | | | | | | | | | | | | | | | | | | | | | | | | | | | | | | | | | | | | | | | | | | | | | | | | | | | | | | | | | | | | | | | |
| A | <p>Probe S3:</p> <table border="1"> <tr> <td>0= User defined;</td> <td>Ratiometric (OUT=0 to 5 V)</td> <td>Electronic (OUT=4 - 20 mA)</td> </tr> <tr> <td>1= -1 to 4.2 barg</td> <td>8= -0.5 to 7 barg</td> <td></td> </tr> <tr> <td>2= 0.4 to 9.3 barg</td> <td>9= 0 to 10 barg</td> <td></td> </tr> <tr> <td>3= -1 to 9.3 barg</td> <td>10= 0 to 18.2 bar</td> <td></td> </tr> <tr> <td>4= 0 to 17.3 barg</td> <td>11= 0 to 25 barg</td> <td></td> </tr> <tr> <td>5= 0.85 to 34.2 barg</td> <td>12= 0 to 30 barg</td> <td></td> </tr> <tr> <td>6= 0 to 34.5 barg</td> <td>13= 0 to 44.8 barg</td> <td></td> </tr> <tr> <td>7= 0 to 45 barg</td> <td>14= remote, -0.5 to 7 barg</td> <td></td> </tr> <tr> <td></td> <td>15= remote, 0 to 10 barg</td> <td></td> </tr> <tr> <td></td> <td>16= remote, 0 to 18.2 barg</td> <td></td> </tr> <tr> <td></td> <td>17= remote, 0 to 25 barg</td> <td></td> </tr> <tr> <td></td> <td>18= remote, 0 to 30 barg</td> <td></td> </tr> <tr> <td></td> <td>19= remote, 0 to 44.8 barg</td> <td></td> </tr> <tr> <td></td> <td>20= 4 to 20mA external signal</td> <td></td> </tr> <tr> <td>21= -1 to 12.8 barg</td> <td></td> <td></td> </tr> <tr> <td>22= 0 to 20.7 barg</td> <td></td> <td></td> </tr> <tr> <td>23= 1.86 to 43.0 barg</td> <td></td> <td></td> </tr> <tr> <td>24= CAREL liquid level</td> <td></td> <td></td> </tr> <tr> <td>25= 0..60,0 barg</td> <td></td> <td></td> </tr> <tr> <td>26= 0..90,0 barg</td> <td></td> <td></td> </tr> <tr> <td>27= external signal 0...5 V</td> <td></td> <td></td> </tr> </table> | 0= User defined; | Ratiometric (OUT=0 to 5 V) | Electronic (OUT=4 - 20 mA) | 1= -1 to 4.2 barg | 8= -0.5 to 7 barg | | 2= 0.4 to 9.3 barg | 9= 0 to 10 barg | | 3= -1 to 9.3 barg | 10= 0 to 18.2 bar | | 4= 0 to 17.3 barg | 11= 0 to 25 barg | | 5= 0.85 to 34.2 barg | 12= 0 to 30 barg | | 6= 0 to 34.5 barg | 13= 0 to 44.8 barg | | 7= 0 to 45 barg | 14= remote, -0.5 to 7 barg | | | 15= remote, 0 to 10 barg | | | 16= remote, 0 to 18.2 barg | | | 17= remote, 0 to 25 barg | | | 18= remote, 0 to 30 barg | | | 19= remote, 0 to 44.8 barg | | | 20= 4 to 20mA external signal | | 21= -1 to 12.8 barg | | | 22= 0 to 20.7 barg | | | 23= 1.86 to 43.0 barg | | | 24= CAREL liquid level | | | 25= 0..60,0 barg | | | 26= 0..90,0 barg | | | 27= external signal 0...5 V | | | Ratiometric: -1 to 9.3 barg | - | - | - | I | 19 | 146 | CO |
| 0= User defined; | Ratiometric (OUT=0 to 5 V) | Electronic (OUT=4 - 20 mA) | | | | | | | | | | | | | | | | | | | | | | | | | | | | | | | | | | | | | | | | | | | | | | | | | | | | | | | | | | | | | | | | | | | | | | |
| 1= -1 to 4.2 barg | 8= -0.5 to 7 barg | | | | | | | | | | | | | | | | | | | | | | | | | | | | | | | | | | | | | | | | | | | | | | | | | | | | | | | | | | | | | | | | | | | | | | | |
| 2= 0.4 to 9.3 barg | 9= 0 to 10 barg | | | | | | | | | | | | | | | | | | | | | | | | | | | | | | | | | | | | | | | | | | | | | | | | | | | | | | | | | | | | | | | | | | | | | | | |
| 3= -1 to 9.3 barg | 10= 0 to 18.2 bar | | | | | | | | | | | | | | | | | | | | | | | | | | | | | | | | | | | | | | | | | | | | | | | | | | | | | | | | | | | | | | | | | | | | | | | |
| 4= 0 to 17.3 barg | 11= 0 to 25 barg | | | | | | | | | | | | | | | | | | | | | | | | | | | | | | | | | | | | | | | | | | | | | | | | | | | | | | | | | | | | | | | | | | | | | | | |
| 5= 0.85 to 34.2 barg | 12= 0 to 30 barg | | | | | | | | | | | | | | | | | | | | | | | | | | | | | | | | | | | | | | | | | | | | | | | | | | | | | | | | | | | | | | | | | | | | | | | |
| 6= 0 to 34.5 barg | 13= 0 to 44.8 barg | | | | | | | | | | | | | | | | | | | | | | | | | | | | | | | | | | | | | | | | | | | | | | | | | | | | | | | | | | | | | | | | | | | | | | | |
| 7= 0 to 45 barg | 14= remote, -0.5 to 7 barg | | | | | | | | | | | | | | | | | | | | | | | | | | | | | | | | | | | | | | | | | | | | | | | | | | | | | | | | | | | | | | | | | | | | | | | |
| | 15= remote, 0 to 10 barg | | | | | | | | | | | | | | | | | | | | | | | | | | | | | | | | | | | | | | | | | | | | | | | | | | | | | | | | | | | | | | | | | | | | | | | |
| | 16= remote, 0 to 18.2 barg | | | | | | | | | | | | | | | | | | | | | | | | | | | | | | | | | | | | | | | | | | | | | | | | | | | | | | | | | | | | | | | | | | | | | | | |
| | 17= remote, 0 to 25 barg | | | | | | | | | | | | | | | | | | | | | | | | | | | | | | | | | | | | | | | | | | | | | | | | | | | | | | | | | | | | | | | | | | | | | | | |
| | 18= remote, 0 to 30 barg | | | | | | | | | | | | | | | | | | | | | | | | | | | | | | | | | | | | | | | | | | | | | | | | | | | | | | | | | | | | | | | | | | | | | | | |
| | 19= remote, 0 to 44.8 barg | | | | | | | | | | | | | | | | | | | | | | | | | | | | | | | | | | | | | | | | | | | | | | | | | | | | | | | | | | | | | | | | | | | | | | | |
| | 20= 4 to 20mA external signal | | | | | | | | | | | | | | | | | | | | | | | | | | | | | | | | | | | | | | | | | | | | | | | | | | | | | | | | | | | | | | | | | | | | | | | |
| 21= -1 to 12.8 barg | | | | | | | | | | | | | | | | | | | | | | | | | | | | | | | | | | | | | | | | | | | | | | | | | | | | | | | | | | | | | | | | | | | | | | | | |
| 22= 0 to 20.7 barg | | | | | | | | | | | | | | | | | | | | | | | | | | | | | | | | | | | | | | | | | | | | | | | | | | | | | | | | | | | | | | | | | | | | | | | | |
| 23= 1.86 to 43.0 barg | | | | | | | | | | | | | | | | | | | | | | | | | | | | | | | | | | | | | | | | | | | | | | | | | | | | | | | | | | | | | | | | | | | | | | | | |
| 24= CAREL liquid level | | | | | | | | | | | | | | | | | | | | | | | | | | | | | | | | | | | | | | | | | | | | | | | | | | | | | | | | | | | | | | | | | | | | | | | | |
| 25= 0..60,0 barg | | | | | | | | | | | | | | | | | | | | | | | | | | | | | | | | | | | | | | | | | | | | | | | | | | | | | | | | | | | | | | | | | | | | | | | | |
| 26= 0..90,0 barg | | | | | | | | | | | | | | | | | | | | | | | | | | | | | | | | | | | | | | | | | | | | | | | | | | | | | | | | | | | | | | | | | | | | | | | | |
| 27= external signal 0...5 V | | | | | | | | | | | | | | | | | | | | | | | | | | | | | | | | | | | | | | | | | | | | | | | | | | | | | | | | | | | | | | | | | | | | | | | | |

| user * | Parameter/description | Def. | Min. | Max. | UOM | Type ** | CAREL SVP | Modbus® | Note |
|--------|---|---|------|------|-----|---------|-----------|---------|------|
| A | Relay configuration: 1= Disabled 2= Alarm relay (open when alarm active) 3= Solenoid valve relay (open in standby) 4= Valve + alarm relay (open in standby and control alarms) 5= Reversed alarm relay (closed in case of alarm) 6= Valve status relay (open if valve is closed) 7= Direct command 8= Faulty closure alarm relay (opened if alarm) 9= Reverse faulty closure alarm relay (closed if alarm) | Alarm relay | - | - | - | I | 57 | 184 | - |
| A | Probe S4: 0= User defined 1= CAREL NTC 2= CAREL NTC-HT high temperature 3= Combined NTC SPKP**T0 4= --- 5= NTC-LT CAREL low temperature | CAREL NTC | - | - | - | I | 20 | 147 | CO |
| A | DI2 Configuration: 1= Disabled 2= Valve regulation optimization after defrost 3= Discharged battery alarm management 4= Valve forced open (at 100%) 5= Regulation start/stop 6= Regulation backup 7= Regulation security | Regulation start/stop (tLAN-RS485) / Regulation backup (pLAN) | - | - | - | I | 10 | 137 | CO |
| C | Variable 1 on display: 1= Valve opening 2= Valve position 3= Current cooling capacity 4= Set point control 5= Superheat 6= Suction temperature 7= Evaporation temperature 8= Evaporation pressure 9= Condensing temperature 10= Condensing pressure 11= Modulating thermostat temperature(*) 12= EPR pressure 13= Hot gas bypass pressure 14= Hot gas bypass temperature 15= CO ₂ gas cooler outlet temperature 16= CO ₂ gas cooler outlet pressure 17= CO ₂ gas cooler pressure set point 18= Probe S1 reading 19= Probe S2 reading 20= Probe S3 reading 21= Probe S4 reading 22= 4 to 20 mA input 23= 0 to 10 V input (*) CANNOT BE SELECTED | Superheat | - | - | - | I | 58 | 185 | - |
| C | Variable 2 on display (see variable 1 on display) | Valve opening | - | - | - | I | 59 | 186 | - |
| C | Probe S1 alarm management: 1= No action 2= Forced valve closing 3= Valve in fixed position 4= Use backup probe S3 (*) (*) CANNOT BE SELECTED | Valve in fixed position | - | - | - | I | 24 | 151 | CO |
| C | Probe S2 alarm management: 1= No action 2= Forced valve closing 3= Valve in fixed position 4= Use backup probe S4 (*) (*) CANNOT BE SELECTED | Valve in fixed position | - | - | - | I | 25 | 152 | CO |
| C | Probe S3 alarm management: 1= No action 2= Forced valve closing 3= Valve in fixed position | No action | - | - | - | I | 26 | 153 | CO |
| C | Probe S4 alarm management: 1= No action 2= Forced valve closing 3= Valve in fixed position | No action | - | - | - | I | 27 | 154 | CO |
| C | Unit of measure: 1= °C/K/barg; 2= °F/psig | °C/K/barg | - | - | - | I | 21 | 148 | CO |

| user* | Parameter/description | Def. | Min. | Max. | UOM | Type** | CAREL SVP | Modbus® | Note |
|---------------|---|---|-------------------------------------|-------------------------------------|-------------------|--------|-----------|---------|------|
| A | DI1 configuration 1= Disabled 2= Valve regulation optimization after defrost 3= Discharged battery alarm management 4= Valve forced open (at 100%) 5= Regulation start/stop 6= Regulation backup 7= Regulation security | Regulation start/stop (tLAN-RS485) / Regulation backup (pLAN) | - | - | - | I | 85 | 212 | CO |
| C | Language: Italiano; English | Italiano | - | - | - | - | - | - | CO |
| C | Auxiliary refrigerant -1= User defined; 0 = same as main regulation 1= R22 2= R134a 3= R404A 4= R407C 5= R410A 6= R507A 7= R290 8= R600 9= R600a 10= R717 11= R744 12= R728 13= R1270 14= R417A 15= R422D 16= R413A 17= R422A 18= R423A 19= R407A 20= R427A 21= R245FA 22= R407F 23=R32 24=HTR01 25= HTR02 26=R23 27 = R1234yf 28 = R1234ze 29 = R455A 30 = R170 31 = R442A 32 = R447A 33 = R448A 34 = R449A 35 = R450A 36 = R452A 37 = R508B 38 = R452B 39 = R513A 40 = R454B 41 = R458A | R404A | - | - | - | I | 96 | 223 | CO |
| PROBES | | | | | | | | | |
| C | S1: calibration offset | 0 | -60(-870), -60 | 60(870), 60 | barg (psig) mA | A | 34 | 33 | CO |
| C | S1: calibration gain, 4 to 20 mA | 1 | -20 | 20 | - | A | 36 | 35 | CO |
| C | Pressure S1: MINIMUM value | -1 | -20 (-290) | Pressure S1: MAXIMUM value | barg (psig) | A | 32 | 31 | CO |
| C | Pressure S1: MAXIMUM value | 9.3 | Pressure S1: MINIMUM value | 200 (2900) | barg (psig) | A | 30 | 29 | CO |
| C | Pressure S1: MINIMUM alarm value | -1 | -20 (-290) | Pressure S1: MAXIMUM alarm value | barg (psig) | A | 39 | 38 | CO |
| C | Pressure S1: MAXIMUM alarm value | 9.3 | Pressure S1: MINIMUM alarm value | 200 (2900) | barg (psig) | A | 37 | 36 | CO |
| C | S2: calibration offset | 0 | -20 (-36), -20 | 20 (36), 20 | °C (°F), volt | A | 41 | 40 | CO |
| C | S2: calibration gain, 0 to 10 V | 1 | -20 | 20 | - | A | 43 | 42 | CO |
| C | Temperature S2: MINIMUM alarm value | -50 | -85(-121) | Temperature S2: MAXIMUM alarm value | °C (°F) | A | 46 | 45 | CO |
| C | Temperature S2: MAXIMUM alarm value | 105 | Temperature S2: MINIMUM alarm value | 200 (392) | °C (°F) | A | 44 | 43 | CO |
| C | S3: calibration offset | 0 | -60 (-870) | 60 (870) | barg (psig) | A | 35 | 34 | CO |
| C | S3: calibration gain, 4 to 20 mA | 1 | -20 | 20 | - | A | 82 | 81 | CO |
| C | Pressure S3 : MINIMUM value | -1 | -20 (-290) | Pressure S3: MAXIMUM value | barg (psig) | A | 33 | 32 | CO |
| C | Pressure S3: MAXIMUM value | 9.3 | Pressure S3: MINIMUM value | 200 (2900) | barg (psig) | A | 31 | 30 | CO |
| C | Pressure S3: MINIMUM alarm value | -1 | -20 (-290) | Pressure S3: MAXIMUM alarm value | barg (psig) | A | 40 | 39 | CO |
| C | Pressure S3: MAXIMUM alarm value | 9.3 | Pressure S3: MINIMUM alarm value | 200 (2900) | barg (psig) | A | 38 | 37 | CO |
| C | S4: calibration offset | 0 | -20 (-36) | 20 (36) | °C (°F) | A | 42 | 41 | CO |
| C | Temperature S4: MINIMUM alarm value | -50 | -85(-121) | Temperature S4: MAXIMUM alarm value | °C (°F) | A | 47 | 46 | CO |
| C | Temperature S4: MAXIMUM alarm value | 105 | Temperature S4: MINIMUM alarm value | 200 (392) | °C (°F) | A | 45 | 44 | CO |
| C | S1/S3 Maximum difference (pressure) | 0 | 0 | 200(2900) | bar(psicg) | A | 114 | 113 | CO |
| C | S2/S4 Maximum difference (temperature) | 0 | 0 | 180(324) | °C (°F) | A | 115 | 114 | CO |
| C | Alarm delay S1 | 0 | 0 | 240 | s | I | 131 | 258 | CO |
| C | Alarm delay S2 | 0 | 0 | 240 | s | I | 132 | 259 | CO |
| C | Alarm delay S3 | 0 | 0 | 240 | s | I | 133 | 260 | CO |
| C | Alarm delay S4 | 0 | 0 | 240 | s | I | 134 | 261 | CO |
| C | Enable S1 | 0 | 0 | 1 | - | D | 16 | 15 | CO |
| C | Enable S2 | 0 | 0 | 1 | - | D | 17 | 16 | CO |
| C | Enable S3 | 0 | 0 | 1 | - | D | 18 | 17 | CO |
| C | Enable S4 | 0 | 0 | 1 | - | D | 19 | 18 | CO |

| user * | Parameter/description | Def. | Min. | Max. | UOM | Type ** | CAREL SVP | Modbus® | Note |
|----------------|---|-------------|---------------------------|---------------------------|-------------|---------|-----------|---------|------|
| CONTROL | | | | | | | | | |
| A | Superheat set point | 11 | LowSH: threshold | 180 (324) | K (°F) | A | 83 | 82 | - |
| A | Valve opening at start-up (evaporator/valve capacity ratio) | 50 | 0 | 100 | % | I | 60 | 187 | - |
| C | Valve open in stand-by (0= disabled= valve closed; 1=enabled = valve open according to parameter "Valve position in stand-by") | 0 | 0 | 1 | - | D | 36 | 35 | - |
| C | Valve position in stand-by 0 = 25% 1...100% = % opening | 0 | 0 | 100 | % | I | 92 | 219 | - |
| C | start-up delay after defrost | 10 | 0 | 60 | min | I | 40 | 167 | CO |
| A | Pre-position time | 6 | 0 | 18000 | s | I | 87 | 214 | - |
| A | Hot gas bypass temperature set point | 10 | -85(-121) | 200 (392) | °C (°F) | A | 84 | 83 | - |
| A | Hot gas bypass pressure set point | 3 | -20 (-290) | 200 (2900) | barg (psig) | A | 85 | 84 | - |
| A | EPR pressure set point | 3.5 | -20 (-290) | 200 (2900) | barg (psig) | A | 86 | 85 | - |
| C | PID: proportional gain | 15 | 0 | 800 | - | A | 87 | 86 | - |
| C | PID: integral time | 150 | 0 | 1000 | s | I | 61 | 188 | - |
| C | PID: derivative time | 5 | 0 | 800 | s | A | 88 | 87 | - |
| A | LowSH protection: threshold | 5 | -40 (-72) | SH set point | K (°F) | A | 89 | 88 | - |
| C | LowSH protection: integral time | 15 | 0 | 800 | s | A | 90 | 89 | - |
| A | LOP protection: threshold | -50 | -85(-121) | MOP protection: threshold | °C (°F) | A | 91 | 90 | - |
| C | LOP protection: integral time | 0 | 0 | 800 | s | A | 92 | 91 | - |
| A | MOP protection: threshold | 50 | LOP protection: threshold | 200 (392) | °C (°F) | A | 93 | 92 | - |
| C | MOP protection: integral time | 20 | 0 | 800 | s | A | 94 | 93 | - |
| A | Enable manual valve positioning | 0 | 0 | 1 | - | D | 32 | 31 | - |
| A | Manual valve position | 0 | 0 | 9999 | step | I | 53 | 180 | - |
| C | Discharge superheat setpoint (CANNOT BE SELECTED) | 35 | -40(-72) | 180 (324) | K (°F) | A | 100 | 99 | - |
| C | Discharge temperature setpoint (CANNOT BE SELECTED) | 105 | -85(-121) | 200 (392) | °C (°F) | A | 101 | 100 | - |
| C | Liquid level perc. set point | 50 | 0 | 100 | % | A | 119 | 118 | - |
| SPECIAL | | | | | | | | | |
| A | HiTcond: threshold - SELECT WITH PROG. CONT. | 80 | -85(-121) | 200 (392) | °C (°F) | A | 58 | 57 | CO |
| C | HiTcond: integral time - SELECT WITH PROG. CONT. | 20 | 0 | 800 | s | A | 57 | 56 | CO |
| A | Modulating thermostat: set point - SELECT WITH PROG. CONT. | 0 | -85(-121) | 200 (392) | °C (°F) | A | 61 | 60 | CO |
| A | Modulating thermostat: differential - SELECT WITH PROG. CONT. | 0.1 | 0.1 (0.2) | 100 (180) | °C (°F) | A | 60 | 59 | CO |
| C | Mod. thermostat: SH set point offset - SELECT WITH PROG. CONT. | 0 | 0 (0) | 100 (180) | K (°F) | A | 59 | 58 | CO |
| C | Coefficient 'A' for CO ₂ control | 3.3 | -100 | 800 | - | A | 95 | 94 | - |
| C | Coefficient 'B' for CO ₂ control | -22.7 | -100 | 800 | - | A | 96 | 95 | - |
| C | Force manual tuning 0=no; 1= yes | 0 | 0 | 1 | - | D | 41 | 40 | - |
| C | Tuning method 0 to 100= automatic selection 101 to 141= manual selection 142 to 254= not allowed 255= PID parameters model identified | 0 | 0 | 255 | - | I | 80 | 207 | - |
| C | Impostazioni di rete | 2 | 0 | 30 | - | I | 74 | 201 | CO |
| | Parity | Bit di stop | Baud rate | | | | | | |
| | 0 | no parity | 2 stop bits | 4800 bps | | | | | |
| | 1 | no parity | 2 stop bits | 9600 bps | | | | | |
| | 2 | no parity | 2 stop bits | 19200 bps | | | | | |
| | 4 | no parity | 1 stop bit | 4800 bps | | | | | |
| | 5 | no parity | 1 stop bit | 9600 bps | | | | | |
| | 6 | no parity | 1 stop bit | 19200 bps | | | | | |
| | 16 | even | 2 stop bits | 4800 bps | | | | | |
| | 17 | even | 2 stop bits | 9600 bps | | | | | |
| | 18 | even | 2 stop bits | 19200 bps | | | | | |
| | 20 | even | 1 stop bit | 4800 bps | | | | | |
| | 21 | even | 1 stop bit | 9600 bps | | | | | |
| | 22 | even | 1 stop bit | 19200 bps | | | | | |
| | 24 | odd | 2 stop bits | 4800 bps | | | | | |
| | 25 | odd | 2 stop bits | 9600 bps | | | | | |
| | 26 | odd | 2 stop bits | 19200 bps | | | | | |
| | 28 | odd | 1 stop bit | 4800 bps | | | | | |
| | 29 | odd | 1 stop bit | 9600 bps | | | | | |
| | 30 | odd | 1 stop bit | 19200 bps | | | | | |
| A | Power supply mode 0= 24 Vac; 1= 24 Vdc | 0 | 0 | 1 | - | D | 47 | 46 | CO |
| C | Enable mode single on twin (parameter disabled) 0= Twin; 1= Single | 0 | 0 | 1 | - | D | 58 | 57 | CO |
| C | Stop manual positioning if net error 0 = Normal operation; 1 = Stop | 0 | 0 | 1 | - | D | 59 | 58 | CO |
| C | Programmable regulation configuration | 0 | 0 | 32767 | - | I | 101 | 228 | - |
| C | Programmable regulation input | 0 | 0 | 32767 | - | I | 102 | 229 | - |
| C | Programmable SH regulation options | 0 | 0 | 32767 | - | I | 103 | 230 | - |
| C | Programmable regulation set point | 0 | -800(-1233) | 800(1233) | - | A | 112 | 111 | - |
| C | CUSTOMIZED REFRIGERANT | | | | | | | | |
| | Dew a high | -288 | -32768 | 32767 | - | I | 107 | 234 | CO |

| user* | Parameter/description | Def. | Min. | Max. | UOM | Type** | CAREL SVP | Modbus® | Note |
|----------------------------|---|--------|-----------|-----------|---------|--------|-----------|---------|------|
| | Dew a low | -15818 | -32768 | 32767 | - | I | 108 | 235 | CO |
| | Dew b high | -14829 | -32768 | 32767 | - | I | 109 | 236 | CO |
| | Dew b low | 16804 | -32768 | 32767 | - | I | 110 | 237 | CO |
| | Dew c high | -11664 | -32768 | 32767 | - | I | 111 | 238 | CO |
| | Dew c low | 16416 | -32768 | 32767 | - | I | 112 | 239 | CO |
| | Dew d high | -23322 | -32768 | 32767 | - | I | 113 | 240 | CO |
| | Dew d low | -16959 | -32768 | 32767 | - | I | 114 | 241 | CO |
| | Dew e high | -16378 | -32768 | 32767 | - | I | 115 | 242 | CO |
| | Dew e low | 15910 | -32768 | 32767 | - | I | 116 | 243 | CO |
| | Dew f high | -2927 | -32768 | 32767 | - | I | 117 | 244 | CO |
| | Dew f low | -17239 | -32768 | 32767 | - | I | 118 | 245 | CO |
| | Bubble a high | -433 | -32768 | 32767 | - | I | 119 | 246 | CO |
| | Bubble a low | -15815 | -32768 | 32767 | - | I | 120 | 247 | CO |
| | Bubble b high | -15615 | -32768 | 32767 | - | I | 121 | 248 | CO |
| | Bubble b low | 16805 | -32768 | 32767 | - | I | 122 | 249 | CO |
| | Bubble c high | 30803 | -32768 | 32767 | - | I | 123 | 250 | CO |
| | Bubble c low | 16416 | -32768 | 32767 | - | I | 124 | 251 | CO |
| | Bubble d high | -21587 | -32768 | 32767 | - | I | 125 | 252 | CO |
| | Bubble d low | -16995 | -32768 | 32767 | - | I | 126 | 253 | CO |
| | Bubble e high | -24698 | -32768 | 32767 | - | I | 127 | 254 | CO |
| | Bubble e low | 15900 | -32768 | 32767 | - | I | 128 | 255 | CO |
| | Bubble f high | 10057 | -32768 | 32767 | - | I | 129 | 256 | CO |
| | Bubble f low | -17253 | -32768 | 32767 | - | I | 130 | 257 | CO |
| C | Faulty closure alarm status 0/1=no/yes | 0 | 0 | 1 | - | D | 49 | 48 | - |
| C | Battery charge delay | 0 | 0 | 250 | min | I | 135 | 262 | CO |
| ALARM CONFIGURATION | | | | | | | | | |
| C | Low superheat alarm delay (LowSH) (0= alarm disabled) | 300 | 0 | 18000 | s | I | 62 | 189 | - |
| C | Low evaporation temperature alarm delay (LOP) (0= alarm disabled) | 300 | 0 | 18000 | s | I | 63 | 190 | - |
| C | High evaporation temperature alarm delay (MOP) (0= alarm disabled) | 600 | 0 | 18000 | s | I | 64 | 191 | - |
| C | High condensing temperature alarm delay (HiTcond) CANNOT BE SELECTED | 600 | 0 | 18000 | s | I | 44 | 171 | CO |
| C | Low suction temperature alarm threshold | -50 | -85(-121) | 200 (392) | °C (°F) | A | 97 | 96 | - |
| C | Low suction temperature alarm delay (0= alarm disabled) | 300 | 0 | 18000 | s | I | 65 | 192 | - |
| VALVE | | | | | | | | | |
| C | EEV minimum steps | 50 | 0 | 9999 | step | I | 66 | 193 | - |
| C | EEV maximum steps | 480 | 0 | 9999 | step | I | 67 | 194 | - |
| C | EEV closing steps | 500 | 0 | 9999 | step | I | 68 | 195 | - |
| C | EEV rated speed | 50 | 1 | 2000 | step/s | I | 69 | 196 | - |
| C | EEV rated current | 450 | 0 | 800 | mA | I | 70 | 197 | - |
| C | EEV holding current | 100 | 0 | 250 | mA | I | 71 | 198 | - |
| C | EEV duty cycle | 30 | 1 | 100 | % | I | 72 | 199 | - |
| C | Synchronise position in opening | 1 | 0 | 1 | - | D | 37 | 36 | - |
| C | Synchronise position in closing | 1 | 0 | 1 | - | D | 38 | 37 | - |

Tab. 8.b

* User level: A= Service (installer), C= manufacturer.

** Type of variable: A= Analogue; D= Digital; I= Integer

CO= parameter settable from driver A or from driver B

8.3 Unit of measure

In the configuration parameters menu, with access by manufacturer password, the user can choose the unit of measure for the driver:

- international system (°C, K, barg);
- imperial system (°F, psig).

 **Note:** the units of measure K and R relate to degrees Kelvin or Rankine adopted for measuring the superheat and the related parameters.

When changing the unit of measure, all the values of the parameters saved on the driver and all the measurements read by the probes will be recalculated. This means that when changing the units of measure, control remains unaltered.

Example 1: The pressure read is 100 barg, this will be immediately converted to the corresponding value of 1450 psig.

Example 2: The "superheat set point" parameter set to 10 K will be immediately converted to the corresponding value of 18 °F.

Example 3: The "Temperature S4: maximum alarm value" parameter, set to 150 °C, will be immediately converted to the corresponding value of 302 °F.

 **Note:** due to limits in the internal arithmetic of the driver, pressure values above 200 barg (2900 psig) and temperature values above 200 °C (392 °F) cannot be converted

8.4 Variables accessible via serial connection – driver A

| | Description | Default | Min | Max | Type | CAREL SVP | Modbus® | R/W |
|------------------------------------|--|---------|----------------|---------------|------|-----------|---------|-----|
| | Probe S1 reading | 0 | -20 (-290) | 200 (2900) | A | 1 | 0 | R |
| | Probe S2 reading | 0 | -85(-121) | 200 (392) | A | 2 | 1 | R |
| | Probe S3 reading | 0 | -20 (-290) | 200 (2900) | A | 3 | 2 | R |
| | Probe S4 reading | 0 | -85(-121) | 200 (392) | A | 4 | 3 | R |
| | Suction temperature | 0 | -85(-121) | 200 (392) | A | 5 | 4 | R |
| | Evaporation temperature | 0 | -85(-121) | 200 (392) | A | 6 | 5 | R |
| | Evaporation pressure | 0 | -20 (-290) | 200 (2900) | A | 7 | 6 | R |
| | Hot gas bypass temperature | 0 | -85(-121) | 200 (392) | A | 8 | 7 | R |
| | EPR pressure (back pressure) | 0 | -20 (-290) | 200 (2900) | A | 9 | 8 | R |
| | Superheat | 0 | -40 (-72) | 180 (324) | A | 10 | 9 | R |
| | Condensing pressure | 0 | -20 (-290) | 200 (2900) | A | 11 | 10 | R |
| | Condensing temperature | 0 | -85(-121) | 200 (392) | A | 12 | 11 | R |
| | Modulating thermostat temperature | 0 | -85(-121) | 200 (392) | A | 13 | 12 | R |
| | Hot gas bypass pressure | 0 | -20 (-290) | 200 (2900) | A | 14 | 13 | R |
| | CO ₂ gas cooler outlet pressure | 0 | -20 (-290) | 200 (2900) | A | 15 | 14 | R |
| | CO ₂ gas cooler outlet temperature | 0 | -85(-121) | 200 (392) | A | 16 | 15 | R |
| | Valve opening | 0 | 0 | 100 | A | 17 | 16 | R |
| | CO ₂ gas cooler pressure set point | 0 | -20 (-290) | 200 (2900) | A | 18 | 17 | R |
| | 4 to 20 mA input value (S1) | 4 | 4 | 20 | A | 19 | 18 | R |
| | 0 to 10 V input value (S2) | 0 | 0 | 10 | A | 20 | 19 | R |
| | Control set point | 0 | -60 (-870) | 200 (2900) | A | 21 | 20 | R |
| | Controller firmware version | 0 | 0 | 800 | A | 25 | 24 | R |
| | MOP: suction temperature threshold (S2) | 30 | -85(-121) | 200 (392) | A | 102 | 101 | R/W |
| | Discharge superheat | 0 | -40(-72) | 180(324) | A | 104 | 103 | R |
| | Discharge temperature | 0 | -60(-76) | 200(392) | A | 105 | 104 | R |
| | Thermal time constant NTC probe S4 | 50 | 1 | 800 | A | 106 | 105 | R/W |
| | MOP: High evaporation temperature threshold | 50 | LOP: threshold | 200 (392) | A | 107 | 106 | R/W |
| | Condensation pressure for subcooling measure | 0 | -20(-290) | 200(2900) | A | 108 | 107 | R |
| | Condensation bubble point | 0 | -60(-76) | 200(392) | A | 109 | 108 | R |
| | Condensation liquid temperature | 0 | -60(-76) | 200(392) | A | 110 | 109 | R |
| | Subcooling | 0 | -40(-72) | 180(324) | A | 111 | 110 | R |
| | Liquid regulation evaporator/ condenser level percentage | 0 | 0 | 100 | A | 116 | 115 | R |
| | Valve position | 0 | 0 | 9999 | I | 4 | 131 | R |
| | Current unit cooling capacity | 0 | 0 | 100 | I | 7 | 134 | R/W |
| | Adaptive control status | - | 0 | 10 | I | 75 | 202 | R |
| | Last tuning result | 0 | 0 | 8 | I | 76 | 203 | R |
| | Extended measured probe S1 (*) | 0 | -2000 (-2901) | 20000 (29007) | I | 83 | 210 | R |
| | Extended measured probe S3 (*) | 0 | -2000 (-2901) | 20000 (29007) | I | 84 | 211 | R |
| | Emergency closing speed valve | 150 | 1 | 2000 | I | 86 | 213 | R/W |
| | Control mode (comp. BLDC) | 1 | 1 | 3 | I | 89 | 216 | R/W |
| | Type of unit for serial comm. | 0 | 0 | 32767 | I | 94 | 221 | R |
| | HW code for serial comm. | 0 | 0 | 32767 | I | 95 | 222 | R |
| | Reading of probe S1*40 | 0 | -32768 | 32767 | I | 97 | 224 | R |
| | Reading of probe S2*40 | 0 | -32768 | 32767 | I | 98 | 225 | R |
| | Reading of probe S3*40 | 0 | -32768 | 32767 | I | 99 | 226 | R |
| | Reading of probe S4*40 | 0 | -32768 | 32767 | I | 100 | 227 | R |
| ALARMS | Low suction temperature | 0 | 0 | 1 | D | 1 | 0 | R |
| | LAN error | 0 | 0 | 1 | D | 2 | 1 | R |
| | EEPROM damaged | 0 | 0 | 1 | D | 3 | 2 | R |
| | Probe S1 | 0 | 0 | 1 | D | 4 | 3 | R |
| | Probe S2 | 0 | 0 | 1 | D | 5 | 4 | R |
| | Probe S3 | 0 | 0 | 1 | D | 6 | 5 | R |
| | Probe S4 | 0 | 0 | 1 | D | 7 | 6 | R |
| | EEV motor error | 0 | 0 | 1 | D | 8 | 7 | R |
| | Status of relay | 0 | 0 | 1 | D | 9 | 8 | R |
| ALARMS | LOP (low evaporation temperature) | 0 | 0 | 1 | D | 10 | 9 | R |
| | MOP (high evaporation temperature) | 0 | 0 | 1 | D | 11 | 10 | R |
| | LowSH (low superheat) | 0 | 0 | 1 | D | 12 | 11 | R |
| | HiTcond (high condensing temperature) | 0 | 0 | 1 | D | 13 | 12 | R |
| | Status of digital input DI1 | 0 | 0 | 1 | D | 14 | 13 | R |
| | Status of digital input DI2 | 0 | 0 | 1 | D | 15 | 14 | R |
| | Guided initial procedure completed | 0 | 0 | 1 | D | 22 | 21 | R/W |
| | Adaptive control ineffective | 0 | 0 | 1 | D | 40 | 39 | R |
| | Mains power failure | 0 | 0 | 1 | D | 45 | 44 | R |
| | Regulation backup from supervisor | 0 | 0 | 1 | D | 46 | 45 | R/W |
| Forced valve closing not completed | 0 | 0 | 1 | D | 49 | 48 | R/W | |
| PROTECT. ACTIV. | LowSH (low superheat) | 0 | 0 | 1 | D | 50 | 49 | R |
| | LOP (low evaporation temperature) | 0 | 0 | 1 | D | 51 | 50 | R |
| | MOP high evaporation temperature) | 0 | 0 | 1 | D | 52 | 51 | R |
| | HiTcond (high condensing temperature) | 0 | 0 | 1 | D | 53 | 52 | R |
| | Direct relay control | 0 | 0 | 1 | D | 57 | 56 | R/W |
| | Enable LAN mode on service serial port (RESERVED) | 0 | 0 | 1 | D | 60 | 59 | R/W |

Tab. 8.c

(*) The displayed variable is to be divided by 100, and allows us to appreciate the hundredth of a bar (psig).

8.5 Variables accessible via serial connection – driver B

| | Description | Default | Min | Max | Type | CAREL SVP | Modbus® | R/W |
|--------|--|---------|---------------|---------------|------|-----------|---------|-----|
| | Valve opening | 0 | 0 | 100 | A | 66 | 65 | R |
| | Control set point | 0 | -60 (-870) | 200 (2900) | A | 67 | 66 | R |
| | Superheat | 0 | -40 (-72) | 180 (324) | A | 68 | 67 | R |
| | Suction temperature | 0 | -85 (-121) | 200 (392) | A | 69 | 68 | R |
| | Evaporation temperature | 0 | -85 (-121) | 200 (392) | A | 70 | 69 | R |
| | Evaporation pressure | 0 | -20 (-290) | 200 (2900) | A | 71 | 70 | R |
| | EPR pressure (back pressure) | 0 | -20 (-290) | 200 (2900) | A | 72 | 71 | R |
| | Hot gas bypass pressure | 0 | -20 (-290) | 200 (2900) | A | 73 | 72 | R |
| | Hot gas bypass temperature | 0 | -85 (-121) | 200 (392) | A | 74 | 73 | R |
| | CO ₂ gas cooler outlet temperature | 0 | -85 (-121) | 200 (392) | A | 75 | 74 | R |
| | CO ₂ gas cooler outlet pressure | 0 | -20 (-290) | 200 (2900) | A | 76 | 75 | R |
| | CO ₂ gas cooler pressure set point | 0 | -20 (-290) | 200 (2900) | A | 77 | 76 | R |
| | 4 to 20 mA input value (S3) | 4 | 4 | 20 | A | 78 | 77 | R |
| | MOP: suction temperature threshold (S4) | 30 | -85 (-121) | 200 (392) | A | 103 | 102 | R/W |
| | Liquid regulation evaporator/ condenser level percentage | 0 | 0 | 100 | A | 117 | 116 | R |
| | Valve position | 0 | 0 | 9999 | I | 49 | 176 | R |
| | Current unit cooling capacity | 0 | 0 | 100 | I | 50 | 177 | R/W |
| | EVD status | 0 | 0 | 20 | I | 51 | 178 | R |
| | Protector status | 0 | 0 | 5 | I | 52 | 179 | R |
| | Control mode | 1 | 1 | 26 | I | 73 | 200 | R/W |
| | Adaptive control status | 0 | 0 | 6 | I | 77 | 204 | R |
| | Last tuning result | 0 | 0 | 8 | I | 78 | 205 | R |
| | Extended measured probe S3 (*) | 0 | -2000 (-2901) | 20000 (29007) | I | 84 | 211 | R |
| | Start control delay | 6 | 0 | 18000 | I | 87 | 214 | R/W |
| | Emergency closing speed valve | 150 | 1 | 2000 | I | 86 | 215 | R/W |
| | Valve opening position % in standby | 0 | 0 | 100 | I | 92 | 219 | R/W |
| ALARMS | LowSH (low superheat) | 0 | 0 | 1 | D | 26 | 25 | R |
| | LOP (low evaporation temperature) | 0 | 0 | 1 | D | 27 | 26 | R |
| | MOP (high evaporation temperature) | 0 | 0 | 1 | D | 28 | 27 | R |
| | Low suction temperature | 0 | 0 | 1 | D | 29 | 28 | R |
| | EEV motor error | 0 | 0 | 1 | D | 30 | 29 | R |
| ALARMS | Status of relay | 0 | 0 | 1 | D | 31 | 30 | R |
| | Adaptive control ineffective | 0 | 0 | 1 | D | 42 | 41 | R |
| | Value backup digital input | 0 | 0 | 1 | D | 48 | 47 | R/W |
| | LowSH protection status | 0 | 0 | 1 | D | 54 | 53 | R |
| | LOP protection status | 0 | 0 | 1 | D | 55 | 54 | R |
| | MOP protection status | 0 | 0 | 1 | D | 56 | 55 | R |
| | Direct relay control | 0 | 0 | 1 | D | 61 | 60 | R/W |

Tab. 8.d

(*) The displayed variable is to be divided by 100, and allows us to appreciate the hundredth of a bar (psig).

Type of variable: A= analogue; D= digital; I= integer

SVP= variable address with CAREL protocol on 485 serial card.

Modbus®: variable address with Modbus® protocol on 485 serial card.

8.6 Variables used based on the type of control

The table below shows the variables used by the drivers depending on the "Main control" parameter. At the end of the variable list are the screens used to check the probe and valve electrical connections for driver A and driver B. These variables are visible on the display by accessing display mode (see paragraph 3.4) and via serial connection with VPM, PlantVisorPRO,... (see paragraphs 8.4, 8.5)

Procedure for showing the variables on the display:

- press the Help and Enter buttons together to select driver A or B;
- press the UP/DOWN button;
- press the DOWN button to move to the next variable/screen;
- press the Esc button to return to the standard display.

| Variable displayed | Main control | | | | | | I/O expander for pCO | Control with level sensor |
|--|-------------------|-------------------------------|------------------------|---------------------|-------------------|----------------------|----------------------|---------------------------|
| | Superheat control | Transcritical CO ₂ | Gas bypass temperature | Gas bypass pressure | EPR back pressure | Analogue positioning | | |
| Valve opening (%) | • | • | • | • | • | • | • | • |
| Valve position (step) | • | • | • | • | • | • | • | • |
| Current unit cooling capacity | • | • | • | • | • | • | | • |
| Set point control | • | • | | • | | | | |
| Superheat | • | | | | | | | |
| Suction temperature | • | | | | | | | |
| Evaporation temperature | • | | | | | | | |
| Evaporation pressure | • | | | | | | | |
| Condensing temperature (*) | | | | | | | | |
| Condensing pressure (*) | | | | | | | | |
| Modulating thermostat temperature(*) | | | | | | | | |
| EPR pressure (back pressure) | | | | | • | | | |
| Hot gas bypass pressure | | | | • | | | | |
| Hot gas bypass temperature | | | • | | | | | |
| CO ₂ gas cooler outlet temperature | | • | | | | | | |
| CO ₂ gas cooler outlet pressure | | • | | | | | | |
| CO ₂ gas cooler pressure set point | | • | | | | | | |
| Probe S1 reading | • | • | • | • | • | • | • | • |
| Probe S2 reading | • | • | • | • | • | • | • | • |
| Probe S3 reading | • | • | • | • | • | • | • | • |
| Probe S4 reading | • | • | • | • | • | • | • | • |
| 4 to 20 mA input value | | | | | | • | • | |
| 0 to 10V input value | | | | | | • | • | |
| Status of digital input DI1 (**) | • | • | • | • | • | • | • | • |
| Status of digital input DI2 (**) | • | • | • | • | • | • | • | • |
| EVD firmware version | • | • | • | • | • | • | • | • |
| Display firmware version | • | • | • | • | • | • | • | • |
| Adaptive control status 0= not enabled or stopper 1= monitoring superheat 2= monitoring suction temperature 3= wait superheat stabilisation 4= wait suction temperature stabilisation 5= applying step 6= positioning valve 7= sampling response to step 8= wait stabilisation in response to step 9= wait tuning improvement 10= stop, max number of attempts exceeded | • | | | | | | | |
| Last tuning result 0= no attempt performed 1= attempt interrupted 2= step application error 3= time constant/delay error 4= model error 5= tuning ended successfully on suction temperature 6= tuning ended successfully on superheat | • | | | | | | | |
| Liquid level percentage | | | | | | | | • |

Tab. 8.e

(*) The value of the variable is not displayed

(**) Status of digital input: 0= open, 1= closed.

 **Note:** the readings of probes S1, S2, S3, S4 is always displayed, regardless of whether or not the probe is connected

9. ALARMS

9.1 Alarms

There are two types of alarms for each driver:

- system: valve motor, EEPROM, probe and communication;
- control: low superheat, LOP, MOP, low suction temperature.

The activation of the alarms depends on the setting of the threshold and activation delay parameters. Setting the delay to 0 disables the alarms. The EEPROM alarm always shuts down the controller.

All the alarms are reset automatically, once the causes are no longer present. The alarm relay contact will open if the relay is configured as alarm relay using the corresponding parameter. The signalling of the alarm event on the driver depends on whether the LED board or the display board is fitted, as shown in the table below.

Note: the alarm LED only comes on for the system alarms, and not for the control alarms.

Example: display system alarm on LED board for driver A and for driver B

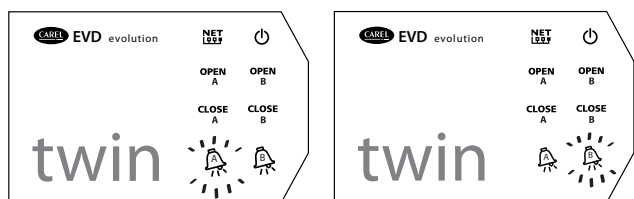

Fig. 9.a

Note: the alarm LED comes on to signal a mains power failure only if the EVBAT*** module (accessory) has been connected, guaranteeing the power required to close the valve.

The display shows both types of alarms, in two different modes:

system alarm: on the main page, the ALARM message is displayed, flashing. Pressing the Help button displays the description of the alarm and, at the top right, the total number of active alarms and the driver where the alarm occurred (A / B). The same alarm may occur on both drivers (e.g. probe alarm)

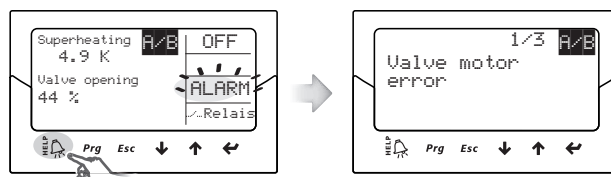

Fig. 9.b

- **control alarm:** next to the flashing ALARM message, the main page shows the type of protector activated.

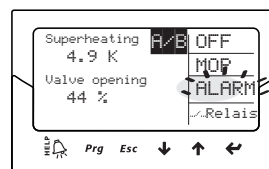

Fig. 9.c

- Note:**
- to display the alarm queue, press the Help button and scroll using the UP/DOWN buttons. If at the end of the alarms for driver A/B the following message is shown:

Alarms active on driver B/A

1. press Esc to return to the standard display;
2. press the Help and Enter buttons together to move to the corresponding driver;
3. press Help to display the required alarm queue.

- the control alarms can be disabled by setting the corresponding delay to zero.

Table of alarms

| Type of alarm | Cause of the alarm | LED | Display | Relay | Reset | Effects on control | Checks/ solutions |
|------------------------------------|---|---------------|------------------------|------------------------------------|-----------|--|--|
| Probe S1 | Probe S1 faulty or exceeded set alarm range | red alarm LED | ALARM flashing | Depends on configuration parameter | automatic | Depends on parameter "Probe S1 alarm management" | Check the probe connections. Check the "Probe S1 alarm management", & "Pressure S1: MINIMUM & MAXIMUM alarm value" parameters |
| Probe S2 | Probe S2 faulty or exceeded set alarm range | red alarm LED | ALARM flashing | Depends on configuration parameter | automatic | Depends on parameter "Probe S2 alarm management" | Check the probe connections. Check the "Probe S2 alarm management", & "Temperature S2: MINIMUM & MAXIMUM alarm value" parameters |
| Probe S3 | Probe S3 faulty or exceeded set alarm range | red alarm LED | ALARM flashing | Depends on configuration parameter | automatic | Depends on parameter "Probe S3 alarm management" | Check the probe connections. Check the "Probe S3 alarm management", & "Pressure S3: MINIMUM & MAXIMUM alarm value" parameters |
| Probe S4 | Probe S4 faulty or exceeded set alarm range | red alarm LED | ALARM flashing | Depends on configuration parameter | automatic | Depends on parameter "Probe S4 alarm management" | Check the probe connections. Check the "Probe S4 alarm management", & "Temperature S4: MINIMUM & MAXIMUM alarm value" |
| LowSH (low superheat) | LowSH protection activated | - | ALARM flashing & LowSH | Depends on configuration parameter | automatic | Protection action already active | Check the "LowSH protection: threshold & alarm delay" parameters |
| LOP (low evaporation temperature) | LOP protection activated | - | ALARM flashing & LOP | Depends on configuration parameter | automatic | Protection action already active | Check the "Protection LOP: threshold & alarm delay" parameters |
| MOP (high evaporation temperature) | MOP protection activated | - | ALARM flashing & MOP | Depends on configuration parameter | automatic | Protection action already active | Check the "MOP protection: threshold & alarm delay" parameters |
| Low suction temperature | Threshold and delay time exceeded | - | ALARM flashing | Depends on configuration parameter | automatic | No effect | Check the threshold and delay parameters. |

| Type of alarm | Cause of the alarm | LED | Display | Relay | Reset | Effects on control | Checks/ solutions |
|-------------------------------|--|---|----------------|--|--|--|--|
| EEPROM damaged | EEPROM for operating and/or unit parameters damaged | red alarm LED | ALARM flashing | Depends on configuration parameter | Replace controller/ Contact service | Total shutdown | Replace the controller/Contact service |
| EEV motor error | Valve motor fault, not connected | red alarm LED | ALARM flashing | Depends on configuration parameter | automatic | Interruption | Check the connections and the condition of the motor. Switch controller off and on again |
| LAN error | LAN network communication error | green NET LED flashing | ALARM flashing | Depends on configuration parameter | automatic | Control based on DI1/DI2 | Check the network address settings |
| | LAN network connection error | NET LED off | ALARM flashing | Depends on configuration parameter | automatic | Control based on DI1/DI2 | Check the connections and that the pCO is on and working |
| Display connection error | No communication between controller and display | - | ERROR message | No change | Replace controller/ display | No effect | Check the controller/display and connectors |
| Driver B disconnected | Connection error, driver B | red alarm LED B | ALARM flashing | Depends on configuration parameter | automatic | Driver B: forced closing Driver A: no effect | Replace the controller |
| Alarms active on driver A (1) | Generic error, driver A | red alarm LED A | ALARM flashing | No change | automatic | No effect | See list of alarms for driver A |
| Alarms active on driver B (2) | Generic error, driver B | red alarm LED B | ALARM flashing | No change | automatic | No effect | See list of alarms for driver B |
| Battery discharged (**) | Battery discharged or faulty or electrical connection interrupted | red alarm LED flashing | Alarm flashing | No change | replace the battery | No effect | If the alarm persists for more than 3 hours (recharge time for EVBAT00500) replace the battery |
| Adaptive control ineffective | Tuning failed | - | ALARM flashing | No change | automatic | No effect | Change "Main control" parameter setting |
| Wrong power supply mode (*) | DC driver power supply with "Power supply mode" parameter set to AC power supply | Green POWER LED flashing Red alarm LED | - | Depends on the configuration parameter | Change "Power supply mode" parameter setting | Total shutdown | Check the "Power supply mode" parameter and power supply |
| Pressure difference | Maximum pressure difference threshold exceeded (S1-S3) | Red alarm LED | ALARM flashing | Depends on the configuration parameter | Automatic | Depends on the "Probe S1/S3 alarm management" parameters | Check the probe connections. Check the parameters "Probe S1/S3 alarm management" and "Pressure S1/S3: MINIMUM and MAXIMUM alarm values" |
| Temperature difference | Maximum pressure difference threshold exceeded (S2-S4) | Red alarm LED | ALARM flashing | Depends on the configuration parameter | Automatic | Depends on the "Probe S2/S4 alarm management" parameters | Check the probe connections. Check the parameters "Probe S2/S4 alarm management" and "Temperature S2/S4: MINIMUM and MAXIMUM alarm values" |

Tab. 9.a

- 1) Message that appears at the end of the list of alarms for driver B.
 2) Message that appears at the end of the list of alarms for driver A.
 (*) In the event of AC power supply with "Power supply mode" set to DC, no alarm is displayed
 (**) Alarm only visible if driver connected to EVDBAT00400 battery module

9.2 Alarm relay configuration

The relay contacts are open when the controller is not powered. During normal operation, the relay can be disabled (and thus will be always open) or configured as:

- alarm relay : during normal operation, the relay contact is closed, and opens when any alarm is activated. It can be used to switch off the compressor and the system in the event of alarms.
- solenoid valve relay : during normal operation, the relay contact is closed, and is open only in standby. There is no change in the event of alarms.
- solenoid valve relay + alarm : during normal operation, the relay contact is closed, and opens in standby and/or for LowSH, MOP, HiTcond and low suction temperature alarms. This is because following such alarms, the user may want to protect the unit by stopping the flow of refrigerant or switching off the compressor. The LOP alarm is excluded, as in the event of low evaporation temperature closing the solenoid valve would worsen the situation.
- Direct control: the relay is actuated by a variable accessible by serial;
- Failed closing alarm relay (open with alarm);
- Reverse failed closing alarm relay (closed with alarm).

In the event of a mains power failure, if the driver is connected to the Ultracap module, the forced emergency valve closing procedure starts and the red LED comes. At the end of the emergency closing procedure, the outcome is indicated by the value of the parameter "Failed closing alarm status":

- 0 = Closing successful;
 1 = Closing failed.

The driver will then switch off. If the closing procedure fails, when next restarting, if the parameter "Relay configuration" = 8 or 9 the display will show the "Battery discharged" alarm and the relay will be activated based on the setting (open or closed).



Note: the "Battery discharged" alarm: has no effect on the positioning of the valve, it is signal-only; is not activated if the driver has a direct current power supply (Vdc).

| Parameter/description | Def. |
|--|-------------|
| Relay configuration: 1= Disabled 2= Alarm relay (open when alarm active) 3= Solenoid valve relay (open in standby) 4= Valve + alarm relay (open in standby and control alarms) 5= Reversed alarm relay (closed in case of alarm) 6= Valve status relay (open if valve is closed) 7= Direct control 8= Failed closing alarm relay(open with alarm) 9= Reverse failed closing alarm relay (closed with alarm) | Alarm relay |

Tab. 9.b

9.3 Probe alarms

The probe alarms are part of the system alarms. When the value measured by one of the probes is outside of the field defined by the parameters corresponding to the alarm limits, an alarm is activated. The limits can be set independently of the range of measurement. Consequently, the field outside of which the alarm is signalled can be restricted, to ensure greater safety of the controlled unit.

Important: in applications that use programmable control it may be necessary to exclude the alarms generated by the probes:

| Parameter/description | Def. | Min. | Max. | UOM |
|-----------------------|------|------|------|-----|
| PROBES | | | | |
| Enable S1 | 1 | 0 | 1 | - |
| Enable S2 | 1 | 0 | 1 | - |
| Enable S3 | 1 | 0 | 1 | - |
| Enable S4 | 1 | 0 | 1 | - |

Note:

- the alarm limits can also be set outside of the range of measurement, to avoid unwanted probe alarms. In this case, the correct operation of the unit or the correct signalling of alarms will not be guaranteed;
- by default, after having selected the type of probe used, the alarm limits will be automatically set to the limits corresponding to the range of measurement of the probe.

| Parameter/description | Def. | Min. | Max. | UOM |
|-----------------------------------|------|------------|------------|-------------|
| PROBESs | | | | |
| S1 alarm MIN pressure (S1_AL_MIN) | -1 | -20 (-290) | S1_AL_MAX | barg (psig) |
| S1 alarm MAX pressure (S1_AL_MAX) | 9.3 | S1_AL_MIN | 200 (2900) | barg (psig) |
| Alarm delay S1 | 0 | 0 | 240 | s |
| S2 alarm MIN temp. (S2_AL_MIN) | -50 | -60 | S2_AL_MAX | °C/°F |
| S2 alarm MAX temp. (S2_AL_MAX) | 105 | S2_AL_MIN | 200 (392) | °C (°F) |
| Alarm delay S2 | 0 | 0 | 240 | s |
| S3 alarm MIN pressure (S3_AL_MIN) | -1 | -20 | S3_AL_MAX | barg (psig) |
| S3 alarm MAX pressure (S3_AL_MAX) | 9.3 | S3_AL_MIN | 200 (2900) | barg (psig) |
| Alarm delay S3 | 0 | 0 | 240 | s |
| S4 alarm MIN temp. (S4_AL_MIN) | -50 | -60 | S4_AL_MAX | °C/°F |
| S4 alarm MAX temp. (S4_AL_MAX) | 105 | S4_AL_MIN | 200 (392) | °C (°F) |
| Alarm delay S4 | 0 | 0 | 240 | s |

Tab. 9.c

The behaviour of the driver in response to probe alarms can be configured, using the manufacturer parameters. The options are:

- no action (control continues but the correct measurement of the variables is not guaranteed);
- forced closing of the valve (control stopped);
- valve forced to the initial position (control stopped).

| Parameter/description | Def. | Min. | Max. | UOM |
|--|-------------------------|------|------|-----|
| CONFIGURATION | | | | |
| Probe S1 alarm management: 1= No action 2= Forced valve closing 3= Valve in fixed position 4= Use backup probe S3 (*) (*)= CANNOT BE SELECTED | Valve in fixed position | - | - | - |
| Probe S2 alarm management: 1= No action 2= Forced valve closing 3= Valve in fixed position 4= Use backup probe S4 (*) (*)= CANNOT BE SELECTED | Valve in fixed position | - | - | - |
| Probe S3 alarm management: 1= No action 2= Forced valve closing 3= Valve in fixed position | No action | - | - | - |
| Probe S4 alarm management: 1= No action 2= Forced valve closing 3= Valve in fixed position | No action | - | - | - |
| CONTROL | | | | |
| Valve opening at start-up (evaporator/valve capacity ratio) | 50 | 0 | 100 | % |

Tab. 9.d

9.4 Control alarms

These are alarms that are only activate during control.

Protector alarms

The alarms corresponding to the LowSH, LOP and MOP protectors are only activated during control when the corresponding activation threshold is exceeded, and only when the delay time defined by the corresponding parameter has elapsed. If a protector is not enabled (integral time= 0 s), no alarm will be signalled. If before the expiry of the delay, the protector control variable returns back inside the corresponding threshold, no alarm will be signalled.

Note: this is a likely event, as during the delay, the protection function will have an effect.

If the delay relating to the control alarms is set to 0 s, the alarm is disabled. The protectors are still active, however. The alarms are reset automatically.

Low suction temperature alarm

The low suction temperature alarm is not linked to any protection function. It features a threshold and a delay, and is useful in the event of probe or valve malfunctions to protect the compressor using the relay to control the solenoid valve or to simply signal a possible risk.

In fact, the incorrect measurement of the evaporation pressure or incorrect configuration of the type of refrigerant may mean the superheat calculated is much higher than the actual value, causing an incorrect and excessive opening of the valve.

A low suction temperature measurement may in this case indicate the probable flooding of the compressor, with corresponding alarm signal. If the alarm delay is set to 0 s, the alarm is disabled. The alarm is reset automatically, with a fixed differential of 3°C above the activation threshold.

Relay activation for control alarms

As mentioned in the paragraph on the configuration of the relay, in the event of LowSH, MOP and low suction temperature alarms, the driver relay will open both when configured as an alarm relay and configured as a solenoid + alarm relay.

In the event of LOP alarms, the driver relay will only open if configured as an alarm relay.

| Parameter/Description | Def. | Min. | Max. | UOM |
|---|------|----------------|----------------|---------|
| CONTROL | | | | |
| LowSH protection: threshold | 5 | -40 (-72) | SH set point | K (°F) |
| LowSH protection: integral time | 15 | 0 | 800 | s |
| LOP protection: threshold | -50 | -60 (-76) | MOP: threshold | °C (°F) |
| LOP protection: integral time | 0 | 0 | 800 | s |
| MOP protection: threshold | 50 | LOP: threshold | 200 (392) | °C (°F) |
| MOP protection: integral time | 20 | 0 | 800 | s |
| ALARM CONFIGURATION | | | | |
| Low superheat alarm delay (LowSH) (0= alarm disabled) | 300 | 0 | 18000 | s |
| Low evaporation temperature alarm delay (LOP) (0= alarm disabled) | 300 | 0 | 18000 | s |
| High evaporation temperature alarm delay (MOP) (0= alarm disabled) | 600 | 0 | 18000 | s |
| Low suction temperature alarm threshold | -50 | -60 (-76) | 200 (392) | °C (°F) |
| Low suction temperature alarm delay | 300 | 0 | 18000 | s |

Tab. 9.e

9.5 EEV motor alarm

At the end of the commissioning procedure and whenever the controller is powered up, the valve motor error recognition procedure is activated. This precedes the forced closing procedure and lasts around 10 s. The valve is kept stationary to allow any valve motor faults or missing or incorrect connections to be detected. In any of these cases, the corresponding alarm is activated, with automatic reset. The controller will go into wait status, as it can longer control the valve. The procedure can be avoided by keeping the respective digital input closed for each driver. In this case, after having powered up the controller, forced closing of the valve is performed immediately.

 **Important:** after having resolved the problem with the motor, it is recommended to switch the controller off and on again to realign the position of the valve. If this is not possible, the automatic procedure for synchronising the position may help solve the problem, nonetheless correct control will not be guaranteed until the next synchronisation.

9.6 LAN error alarm

 **Note:** in the event of LAN error, a parameter can be set to disable "Manual positioning".

If the connection to the LAN network is offline for more than 6s due to an electrical problem, the incorrect configuration of the network addresses or the malfunction of the pCO controller, a LAN error alarm will be signalled. The LAN error affects the operation of the controller as follows:

- **case 1:** unit in standby, digital input DI1/DI2 disconnected; driver A/B will remain permanently in standby and control will not be able to start;
- **case 2:** unit in control, digital input DI1/DI2 disconnected: the driver will stop control and will go permanently into standby;
- **case 3:** unit in standby, digital input DI1/DI2 connected: the driver will remain in standby, however control will be able to start if the digital input is closed. In this case, it will start with "current cooling capacity"= 100%;
- **case 4:** unit in control, digital input DI1/DI2 connected: driver A/B will remain in control status, maintaining the value of the "current cooling capacity". If the digital input opens, the driver will go to standby and control will be able to start again when the input closes. In this case, it will start with "current cooling capacity"= 100%.

10. TROUBLESHOOTING

The following table lists a series of possible malfunctions that may occur when starting and operating the driver and the electronic valve. These cover the most common problems and are provided with the aim of offering an initial response for resolving the problem.

| PROBLEM | CAUSE | SOLUTION |
|---|--|--|
| The superheat value measured is incorrect | The probe does not measure correct values | Check that the pressure and the temperature measured are correct and that the probe position is correct. Check that the minimum and maximum pressure parameters for the pressure transducer set on the driver correspond to the range of the pressure probe installed. Check the correct probe electrical connections. |
| | The type of refrigerant set is incorrect | Check and correct the type of refrigerant parameter. |
| Liquid returns to the compressor during control | The type of valve set is incorrect | Check and correct the type of valve parameter. |
| | The valve is connected incorrectly (rotates in reverse) and is open | Check the movement of the valve by placing it in manual control and closing or opening it completely. One complete opening must bring a decrease in the superheat and vice-versa. If the movement is reversed, check the electrical connections. |
| | The superheat set point is too low | Increase the superheat set point. Initially set it to 12 °C and check that there is no longer return of liquid. Then gradually reduce the set point, always making sure there is no return of liquid. |
| | Low superheat protection ineffective | If the superheat remains low for too long with the valve that is slow to close, increase the low superheat threshold and/or decrease the low superheat integral time. Initially set the threshold 3 °C below the superheat set point, with an integral time of 3-4 seconds. Then gradually lower the low superheat threshold and increase the low superheat integral time, checking that there is no return of liquid in any operating conditions. |
| | Stator broken or connected incorrectly | Disconnect the stator from the valve and the cable and measure the resistance of the windings using an ordinary tester. The resistance of both should be around 36 ohms. Otherwise replace the stator. Finally, check the electrical connections of the cable to the driver. |
| | Valve stuck open | Check if the superheating is always low (<2 °C) with the valve position permanently at 0 steps. If so, set the valve to manual control and close it completely. If the superheat is always low, check the electrical connections and/or replace the valve. |
| | The "valve opening at start-up" parameter is too high on many showcases in which the control set point is often reached (for multiplexed showcases only) | Decrease the value of the "Valve opening at start-up" parameter on all the utilities, making sure that there are no repercussions on the control temperature. |
| Liquid returns to the compressor only after defrosting (for multiplexed showcases only) | The pause in control after defrosting is too short (for MasterCase, MasterCase 2 and mpXPRO only) | Increase the value of the "valve control delay after defrosting" parameter. |
| | The superheat temperature measured by the driver after defrosting and before reaching operating conditions is very low for a few minutes | Check that the LowSH threshold is greater than the superheat value measured and that the corresponding protection is activated (integral time > 0sec). If necessary, decrease the value of the integral time. |
| | The superheat temperature measured by the driver does not reach low values, but there is still return of liquid to the compressor rack | Set more reactive parameters to bring forward the closing of the valve: increase the proportional factor to 30, increase the integral time to 250 sec and increase the derivative time to 10 sec. |
| | Many showcases defrosting at the same time | Stagger the start defrost times. If this is not possible, if the conditions in the previous two points are not present, increase the superheat set point and the LowSH thresholds by at least 2 °C on the showcases involved. |
| | The valve is significantly oversized | Replace the valve with a smaller equivalent. |
| Liquid returns to the compressor only when starting the controller (after being OFF) | The "valve opening at start-up" parameter is set too high | Check the calculation in reference to the ratio between the rated cooling capacity of the evaporator and the capacity of the valve; if necessary, lower the value. |
| The superheat value swings around the set point with an amplitude greater than 4°C | The condensing pressure swings | Check the controller condenser settings, giving the parameters "bladder" values (e.g. increase the proportional band or increase the integral time). Note: the required stability involves a variation within +/- 0.5 bars. If this is not effective or the settings cannot be changed, adopt electronic valve control parameters for perturbed systems (see paragraph 8.3) |
| | The superheat swings even with the valve set in manual control (in the position corresponding to the average of the working values) | Check for the causes of the swings (e.g. low refrigerant charge) and resolve where possible. If not possible, adopt electronic valve control parameters for perturbed systems (see paragraph 8.3). |
| | The superheat does NOT swing with the valve set in manual control (in the position corresponding to the average of the working values) | As a first approach, decrease (by 30 to 50 %) the proportional factor. Subsequently try increasing the integral time by the same percentage. In any case, adopt parameter settings recommended for stable systems. |
| | The superheat set point is too low | Increase the superheat set point and check that the swings are reduced or disappear. Initially set 13 °C, then gradually reduce the set point, making sure the system does not start swinging again and that the unit temperature reaches the control set point. |

| PROBLEM | CAUSE | SOLUTION |
|---|--|---|
| In the start-up phase with high evaporator temperatures, the evaporation pressure is high | MOP protection disabled or ineffective | Activate the MOP protection by setting the threshold to the required saturated evaporation temperature (high evaporation temperature limit for the compressors) and setting the MOP integral time to a value above 0 (recommended 4 seconds). To make the protection more reactive, decrease the MOP integral time. |
| | Refrigerant charge excessive for the system or extreme transitory conditions at start-up (for showcases only). | Apply a "soft start" technique, activating the utilities one at a time or in small groups. If this is not possible, decrease the values of the MOP thresholds on all the utilities. |
| In the start-up phase the low pressure protection is activated (only for units with compressor on board) | The "Valve opening at start-up" parameter is set too low | Check the calculation in reference to the ratio between the rated cooling capacity of the evaporator and the capacity of the valve; if necessary increase the value. |
| | The driver in configuration does not start control and the valve remains closed | Check the connections. Check that the pCO application connected to the driver (where featured) correctly manages the driver start signal. Check that the driver is NOT in stand-alone mode. |
| | The driver in stand-alone configuration does not start control and the valve remains closed | Check the connection of the digital input. Check that when the control signal is sent that the input is closed correctly. Check that the driver is in stand-alone mode. |
| | LOP protection disabled | Set a LOP integral time greater than 0 sec. |
| | LOP protection ineffective | Make sure that the LOP protection threshold is at the required saturated evaporation temperature (between the rated evaporation temperature of the unit and the corresponding temperature at the calibration of the low pressure switch) and decrease the value of the LOP integral time. |
| | Solenoid blocked | Check that the solenoid opens correctly, check the electrical connections and the operation of the relay. |
| | Insufficient refrigerant | Check that there are no bubbles in the sight glass upstream of the expansion valve. Check that the subcooling is suitable (greater than 5 °C); otherwise charge the circuit. |
| | The valve is connected incorrectly (rotates in reverse) and is open | Check the movement of the valve by placing it in manual control and closing or opening it completely. One complete opening must bring a decrease in the superheat and vice-versa. If the movement is reversed, check the electrical connections. |
| | Stator broken or connected incorrectly | Disconnect the stator from the valve and the cable and measure the resistance of the windings using an ordinary tester. The resistance of both should be around 36 ohms. Otherwise replace the stator. Finally, check the electrical connections of the cable to the driver. |
| | The "Valve opening at start-up" parameter is set too low | Check the calculation in reference to the ratio between the rated cooling capacity of the evaporator and the capacity of the valve; if necessary lower the value. |
| The unit switches off due to low pressure during control (only for units with compressor on board) | LOP protection disabled | Set a LOP integral time greater than 0 sec. |
| | LOP protection ineffective | Make sure that the LOP protection threshold is at the required saturated evaporation temperature (between the rated evaporation temperature of the unit and the corresponding temperature at the calibration of the low pressure switch) and decrease the value of the LOP integral time. |
| | Solenoid blocked | Check that the solenoid opens correctly, check the electrical connections and the operation of the control relay. |
| | Insufficient refrigerant | Check that there are no bubbles of air in the liquid indicator upstream of the expansion valve. Check that the subcooling is suitable (greater than 5 °C); otherwise charge the circuit. |
| | The valve is significantly undersized | Replace the valve with a larger equivalent. |
| | Stator broken or connected incorrectly | Disconnect the stator from the valve and the cable and measure the resistance of the windings using an ordinary tester. The resistance of both should be around 36 ohms. Otherwise replace the stator. Finally, check the electrical connections of the cable to the driver (see paragraph 5.1). |
| | Valve stuck closed | Use manual control after start-up to completely open the valve. If the superheat remains high, check the electrical connections and/or replace the valve. |
| The showcase does not reach the set temperature, despite the valve being opened to the maximum (for multiplexed showcases only) | Solenoid blocked | Check that the solenoid opens correctly, check the electrical connections and the operation of the relay. |
| | Insufficient refrigerant | Check that there are no bubbles of air in the liquid indicator upstream of the expansion valve. Check that the subcooling is suitable (greater than 5 °C); otherwise charge the circuit. |
| | The valve is significantly undersized | Replace the valve with a larger equivalent. |
| | Stator broken or connected incorrectly | Disconnect the stator from the valve and the cable and measure the resistance of the windings using an ordinary tester. The resistance of both should be around 36 ohms. Otherwise replace the stator. Finally, check the electrical connections of the cable to the driver (see paragraph 5.1). |
| | Valve stuck closed | Use manual control after start-up to completely open the valve. If the superheat remains high, check the electrical connections and/or replace the valve. |
| The showcase does not reach the set temperature, and the position of the valve is always 0 (for multiplexed showcases only) | The driver in configuration does not start control and the valve remains closed | Check the connections. Check that the pCO application connected to the driver (where featured) correctly manages the driver start signal. Check that the driver is NOT in stand-alone mode. |
| | The driver in stand-alone configuration does not start control and the valve remains closed | Check the connection of the digital input. Check that when the control signal is sent that the input is closed correctly. Check that the driver is in stand-alone mode. |

Tab. 10.a

11. TECHNICAL SPECIFICATIONS

| | | | | | | | | | |
|--|--|----|---|----|--|----|---|----|--|
| Power supply (Lmax= 5 m) | • 24 Vac (+10/-15%) to be protected by external 2 A type T fuse. • 24 Vdc (+10/-15%) 50/60 Hz to be protected by external 2 A type T fuse. Use a dedicated class 2 transformer (max 100 VA). | | | | | | | | |
| Power input | 16.2 W ; 35 VA | | | | | | | | |
| Emergency power supply | 22 Vdc+/-5%. (If the optional EVBAT00400 module is installed), Lmax=5 m | | | | | | | | |
| Insulation between relay output and other outputs | reinforced; 6 mm in air, 8 mm on surface; 3750 V insulation | | | | | | | | |
| Motor connection | 4-wire shielded cable AWG 22, Lmax 10 m or AWG 14, Lmax= 50 m | | | | | | | | |
| Digital input connection | Digital input to be activated from voltage-free contact or transistor to GND. Closing current 5 mA; Lmax< 30 m | | | | | | | | |
| Probes (Lmax=10 m; with shielded cable less than 30 m) | <table border="1" style="width: 100%; border-collapse: collapse;"> <tr> <td style="width: 5%; text-align: center;">S1</td> <td> ratiometric pressure probe (0 to 5 V): • resolution 0.1 % fs; • measurement error: 2% fs maximum; 1% typical electronic pressure probe (4 to 20 mA): • resolution 0.5 % fs; • measurement error: 8% fs maximum; 7% typical remote electronic pressure probe (4 to 20mA). Maximum number of drivers connected=5 combined ratiometric pressure probe (0 to 5 V): • resolution 0.1 % fs; • measurement error: 2 % fs maximum; 1 % typical 4 to 20 mA input (max 24 mA): • resolution 0.5% fs; • measurement error: 8% fs maximum; 7% typical 0 to 5 V input: • resolution 0.1 % FS; • measurement error: 2% FS maximum; 1% typical </td> </tr> <tr> <td style="text-align: center;">S2</td> <td> low temperature NTC: • 10 kΩ at 25°C, -50T90 °C; • measurement error: 1°C in range -50T50 °C; 3°C in range +50T90 °C high temperature NTC: • 50 kΩ at 25°C, -40T150 °C; • measurement error: 1.5 °C in range -20T115 °C, 4 °C in range outside of -20T115 °C Combined NTC: • 10 kΩ at 25 °C, -40T120 °C; • measurement error: 1 °C in range -40T50 °C; 3°C in range +50T90 °C 0 to 10 V input (max 12 V): • resolution 0.1 % fs; • measurement error: 9% fs maximum; 8% typical </td> </tr> <tr> <td style="text-align: center;">S3</td> <td> ratiometric pressure probe (0 to 5 V): • resolution 0.1 % fs; • measurement error: 2% fs maximum; 1% typical electronic pressure probe (4 to 20 mA): • resolution 0.5 % fs; • measurement error: 8% fs maximum; 7% typical remote electronic pressure probe (4 to 20mA). Maximum number of drivers connected=5 4 to 20 mA input (max 24 mA): • resolution 0.5% fs; • measurement error: 8% fs maximum; 7% typical combined ratiometric pressure probe (0 to 5 V): • resolution 0.1 % fs, • measurement error: 2 % fs maximum; 1 % typical 0 to 5 V input: • resolution 0.1 % FS; • measurement error: 2% FS maximum; 1% typical </td> </tr> <tr> <td style="text-align: center;">S4</td> <td> low temperature NTC: • 10 kΩ at 25°C, -50T105°C; • measurement error: 1°C in range -50T50 °C; 3°C in range 50T90°C high temperature NTC: • 50 kΩ at 25°C, -40T150°C; • measurement error: 1.5°C in range -20T115°C 4°C in range outside of -20T115°C Combined NTC: • 10 kΩ at 25°C, -40T120°C; • measurement error 1°C in range -40T50°C; 3°C in range +50T90°C </td> </tr> </table> | S1 | ratiometric pressure probe (0 to 5 V): • resolution 0.1 % fs; • measurement error: 2% fs maximum; 1% typical electronic pressure probe (4 to 20 mA): • resolution 0.5 % fs; • measurement error: 8% fs maximum; 7% typical remote electronic pressure probe (4 to 20mA). Maximum number of drivers connected=5 combined ratiometric pressure probe (0 to 5 V): • resolution 0.1 % fs; • measurement error: 2 % fs maximum; 1 % typical 4 to 20 mA input (max 24 mA): • resolution 0.5% fs; • measurement error: 8% fs maximum; 7% typical 0 to 5 V input: • resolution 0.1 % FS; • measurement error: 2% FS maximum; 1% typical | S2 | low temperature NTC: • 10 kΩ at 25°C, -50T90 °C; • measurement error: 1°C in range -50T50 °C; 3°C in range +50T90 °C high temperature NTC: • 50 kΩ at 25°C, -40T150 °C; • measurement error: 1.5 °C in range -20T115 °C, 4 °C in range outside of -20T115 °C Combined NTC: • 10 kΩ at 25 °C, -40T120 °C; • measurement error: 1 °C in range -40T50 °C; 3°C in range +50T90 °C 0 to 10 V input (max 12 V): • resolution 0.1 % fs; • measurement error: 9% fs maximum; 8% typical | S3 | ratiometric pressure probe (0 to 5 V): • resolution 0.1 % fs; • measurement error: 2% fs maximum; 1% typical electronic pressure probe (4 to 20 mA): • resolution 0.5 % fs; • measurement error: 8% fs maximum; 7% typical remote electronic pressure probe (4 to 20mA). Maximum number of drivers connected=5 4 to 20 mA input (max 24 mA): • resolution 0.5% fs; • measurement error: 8% fs maximum; 7% typical combined ratiometric pressure probe (0 to 5 V): • resolution 0.1 % fs, • measurement error: 2 % fs maximum; 1 % typical 0 to 5 V input: • resolution 0.1 % FS; • measurement error: 2% FS maximum; 1% typical | S4 | low temperature NTC: • 10 kΩ at 25°C, -50T105°C; • measurement error: 1°C in range -50T50 °C; 3°C in range 50T90°C high temperature NTC: • 50 kΩ at 25°C, -40T150°C; • measurement error: 1.5°C in range -20T115°C 4°C in range outside of -20T115°C Combined NTC: • 10 kΩ at 25°C, -40T120°C; • measurement error 1°C in range -40T50°C; 3°C in range +50T90°C |
| S1 | ratiometric pressure probe (0 to 5 V): • resolution 0.1 % fs; • measurement error: 2% fs maximum; 1% typical electronic pressure probe (4 to 20 mA): • resolution 0.5 % fs; • measurement error: 8% fs maximum; 7% typical remote electronic pressure probe (4 to 20mA). Maximum number of drivers connected=5 combined ratiometric pressure probe (0 to 5 V): • resolution 0.1 % fs; • measurement error: 2 % fs maximum; 1 % typical 4 to 20 mA input (max 24 mA): • resolution 0.5% fs; • measurement error: 8% fs maximum; 7% typical 0 to 5 V input: • resolution 0.1 % FS; • measurement error: 2% FS maximum; 1% typical | | | | | | | | |
| S2 | low temperature NTC: • 10 kΩ at 25°C, -50T90 °C; • measurement error: 1°C in range -50T50 °C; 3°C in range +50T90 °C high temperature NTC: • 50 kΩ at 25°C, -40T150 °C; • measurement error: 1.5 °C in range -20T115 °C, 4 °C in range outside of -20T115 °C Combined NTC: • 10 kΩ at 25 °C, -40T120 °C; • measurement error: 1 °C in range -40T50 °C; 3°C in range +50T90 °C 0 to 10 V input (max 12 V): • resolution 0.1 % fs; • measurement error: 9% fs maximum; 8% typical | | | | | | | | |
| S3 | ratiometric pressure probe (0 to 5 V): • resolution 0.1 % fs; • measurement error: 2% fs maximum; 1% typical electronic pressure probe (4 to 20 mA): • resolution 0.5 % fs; • measurement error: 8% fs maximum; 7% typical remote electronic pressure probe (4 to 20mA). Maximum number of drivers connected=5 4 to 20 mA input (max 24 mA): • resolution 0.5% fs; • measurement error: 8% fs maximum; 7% typical combined ratiometric pressure probe (0 to 5 V): • resolution 0.1 % fs, • measurement error: 2 % fs maximum; 1 % typical 0 to 5 V input: • resolution 0.1 % FS; • measurement error: 2% FS maximum; 1% typical | | | | | | | | |
| S4 | low temperature NTC: • 10 kΩ at 25°C, -50T105°C; • measurement error: 1°C in range -50T50 °C; 3°C in range 50T90°C high temperature NTC: • 50 kΩ at 25°C, -40T150°C; • measurement error: 1.5°C in range -20T115°C 4°C in range outside of -20T115°C Combined NTC: • 10 kΩ at 25°C, -40T120°C; • measurement error 1°C in range -40T50°C; 3°C in range +50T90°C | | | | | | | | |
| Relay output | normally open contact; 5 A, 250 Vac resistive load; 2 A, 250 Vac inductive load (PF=0.4); Lmax=50 m; UL: 250 Vac, 5 A resistive, 1A FLA, 6A LRA, pilot duty D300. 30000 cycles VDE: 1(1)A PF=0.6 | | | | | | | | |
| Power supply to active probes (V _{ref}) | +5 Vdc ±2% o 12 Vdc ±10% depending on type of probe set | | | | | | | | |
| RS485 serial connection | Lmax=1000 m, shielded cable | | | | | | | | |
| tLAN connection | Lmax=30 m, shielded cable | | | | | | | | |
| pLAN connection | Lmax=500 m, shielded cable | | | | | | | | |
| Assembly | DIN rail | | | | | | | | |
| Connectors | plug-in, cable size 0.5 to 2.5 mm ² (12 to 20 AWG) | | | | | | | | |
| Dimensions | LxHxW= 70x110x60 | | | | | | | | |
| Operating conditions | -25T60°C (don't use EVDIS* under -20°C); <90% RH non-condensing | | | | | | | | |
| Storage conditions | -35T60°C (don't store EVDIS* under -30°C), humidity 90% RH non-condensing | | | | | | | | |
| Index of protector | IP20 | | | | | | | | |
| Environmental pollution | 2 (normal) | | | | | | | | |
| Resistance to heat and fire | Category D | | | | | | | | |
| Immunity against voltage surges | Category 1 | | | | | | | | |
| Rated impulse voltage | 2500V | | | | | | | | |
| Type of relay action | 1C microswitching | | | | | | | | |
| Insulation class | 2 | | | | | | | | |
| Software class and structure | A | | | | | | | | |
| Conformity | Electrical safety: EN 60730-1, EN 61010-1, UL873, VDE 0631-1 Electromagnetic compatibility: EN 61000-6-1, EN 61000-6-2, EN 61000-6-3, EN 61000-6-4; EN61000-3-2, EN55014-1, EN55014-2, EN61000-3-3. | | | | | | | | |

Tab. 11.a

12. APPENDIX 1: VPM (VISUAL PARAMETER MANAGER)

12.1 Installation

On the <http://ksa.carel.com> website, under the Parametric Controller Software section, select Visual Parameter Manager.

A window opens, allowing 3 files to be downloaded:

1. VPM_CD.zip: for burning to a CD;
2. Upgrade setup;
3. Full setup: the complete program.

For first installations, select Full setup, for upgrades select Upgrade setup. The program is installed automatically, by running setup.exe.

Note: if deciding to perform the complete installation (Full setup), first uninstall any previous versions of VPM.

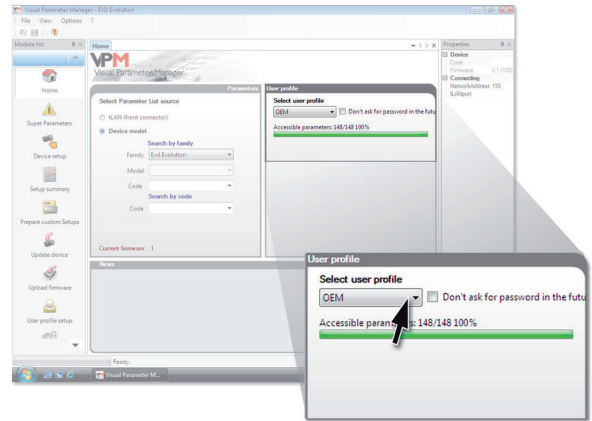

Fig. 12.c

12.2 Programming (VPM)

When opening the program, the user needs to choose the device being configured: EVD evolution. The Home page then opens, with the choice to create a new project or open an existing project. Choose new project and enter the password, which when accessed the first time can be set by the user..

2. select the model from the range and create a new project or choose an existing project: select "Device model".

A new project can be created, making the changes and then connecting later on to transfer the configuration (OFFLINE mode). Enter at the Service or Manufacturer level.

- select Device model and enter the corresponding code

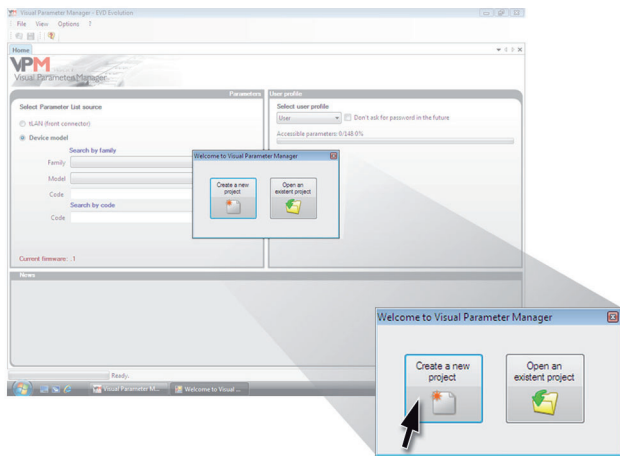

Fig. 12.a

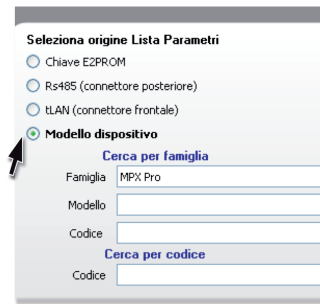

Fig. 12.d

Then the user can choose to:

1. directly access the list of parameters for the EVD evolution twin saved to EEPROM: select "tLAN";

This is done in real time (ONLINE mode), at the top right set the network address 198 and choose the guided recognition procedure for the USB communication port. Enter at the Service or Manufacturer level.

- go to Configure device: the list of parameters will be displayed, allowing the changes relating to the application to be made.

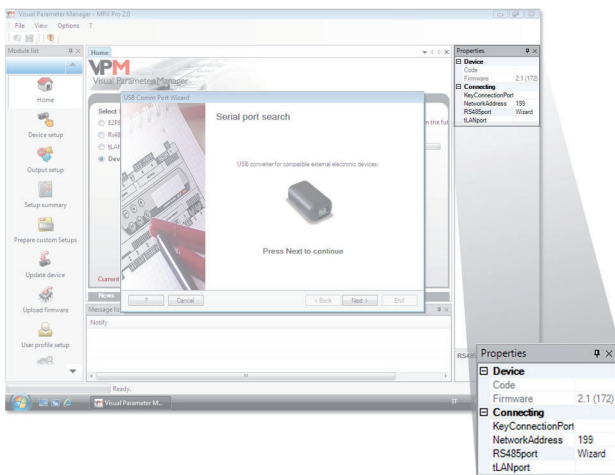

Fig. 12.b

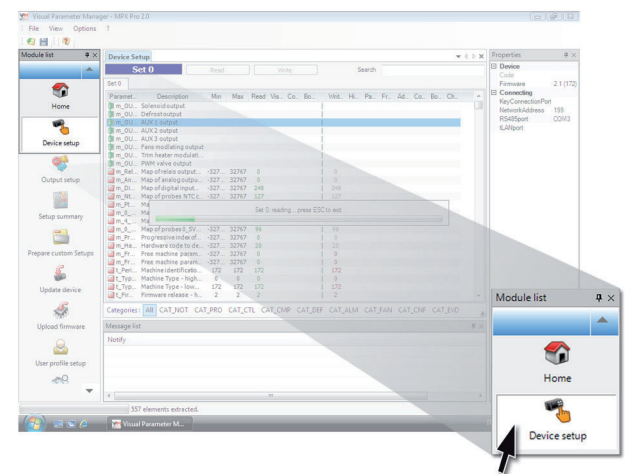

Fig. 12.e

At the end of configuration, to save the project choose the following command, used to save the configuration as a file with the .hex extension.

File -> Save parameter list.

To transfer the parameters to the controller, choose the "Write" command. During the write procedure, the 2 LEDs on the converter will flash.

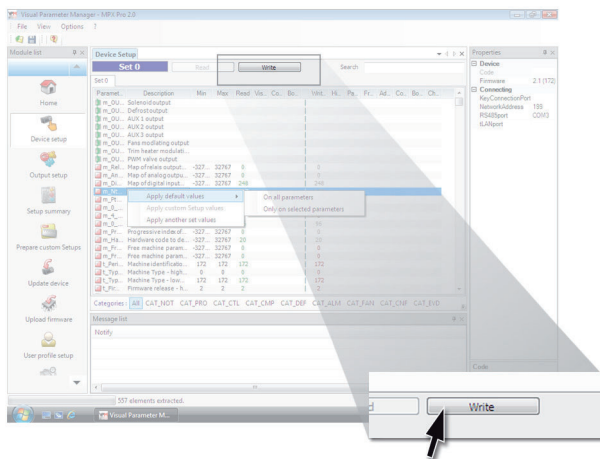



Fig. 12.f

 **Note:** the program On-line help can be accessed by pressing F1.

12.3 Copying the setup

On the Configure device page, once the new project has been created, to transfer the list of configuration parameters to another controller:

- read the list of parameters from the source controller with the “Read” command;
- remove the connector from the service serial port;
- connect the connector to the service port on the destination controller;
- write the list of parameters to the destination controller with the “Write” command.

 **Important:** the parameters can only be copied between controllers with the same code. Different firmware versions may cause compatibility problems.

12.4 Setting the default parameters

When the program opens:

- select the model from the range and load the associated list of parameters;
- go to “Configure device”: the list of parameters will be shown, with the default settings.
- connect the connector to the service serial port on the destination controller;
- select “Write”. During the write procedure, the LEDs on the converter will flash.

The controller parameters will now have the default settings.

12.5 Updating the controller and display firmware

The controller and display firmware must be updated using the VPM program on a computer and the USB/tLAN converter, which is connected to the device being programmed (see paragraph 2.7 for the connection diagram). The firmware can be downloaded from <http://ksa.carel.com>. See the VPM On-line help.

13. APPENDIX 2: EVD EVOLUTION SINGLE

Setting the “Enable single mode on twin” parameter, EVD Evolution twin effectively becomes an EVD Evolution with single driver and manages valve A only. In addition, it acquires the main control functions that require more than two probes, such as superheat control with brushless DC compressor (BLDC), superheat control with two temperature probes and all the auxiliary control functions. The following explanations are available in manual +0300005EN; refer to this manual for a complete description.

13.1 Enable single mode on twin

Parameter to be set at the end of the commissioning procedure.

| Parameter/Description | Def | Min | Max | UoM |
|----------------------------|-----|-----|-----|-----|
| SPECIAL | | | | |
| Enable single mode on twin | 0 | 0 | 1 | - |
| 0 = Twin; 1 = Single | | | | |

Tab. 13.a

13.2 User interface – LED card

The Open B/Close B LEDs flash.

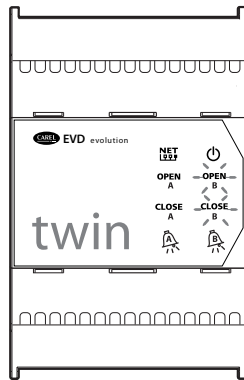

Fig. 13.a

13.3 Connection diagram - superheat control

EVD Evolution Twin works as a single valve driver (on driver A).

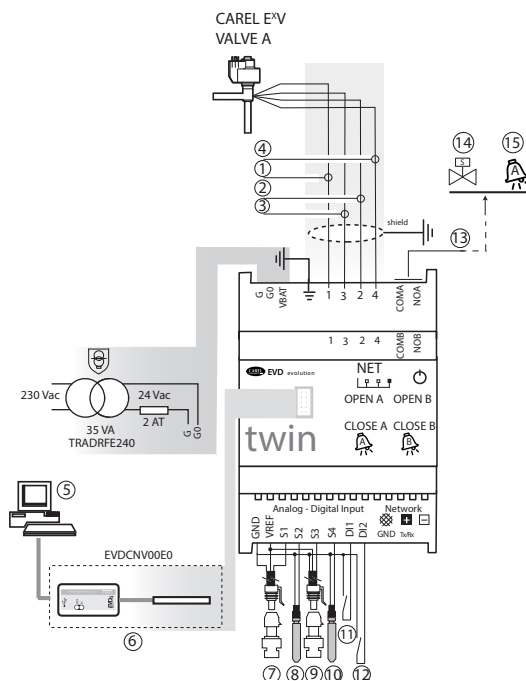

Fig. 13.b

Key:

| | |
|---|--------|
| 1 | green |
| 2 | yellow |
| 3 | brown |

| | |
|----|--|
| 4 | white |
| 5 | personal computer for configuration |
| 6 | USB/tLAN converter |
| 7 | adapter |
| 8 | ratiometric pressure transducer - evaporation pressure |
| 9 | NTC suction temperature |
| 10 | digital input 1 configured to enable control |
| 11 | free contact (up to 230 Vac) |
| 12 | solenoid valve |
| 13 | alarm signal |



Note:

- connect the valve cable shield to the electrical panel earth;
- the use of the driver for the superheat control requires the use of the evaporation pressure probe S1 and the suction temperature probe S2, which will be fitted after the evaporator, and digital input 1/2 to enable control. As an alternative to digital input 1/2, control can be enabled via remote signal (tLAN, pLAN, RS485). For the positioning of the probes relating to other applications, see the chapter on “Control”;
- inputs S1, S2 are programmable and the connection to the terminals depends on the setting of the parameters. See the chapters on “Commissioning” and “Functions”;
- pressure probe S1 in the diagram is ratiometric. See the general connection diagram for the other electronic probes, 4 to 20 mA or combined;
- four probes are needed for superheat control with BLDC compressors, two to measure the superheat and two to measure the discharge superheat and the discharge temperature.

13.4 Parameters enabled/disabled for control

The following parameters are made available in this mode. Probe S3 is no longer setttable as an external 4 to 20 mA signal.

| Parameter/Description | Def. / UoM |
|--|--------------------------------|
| CONFIGURATION | |
| Main control | Multiplexed showcase/cold room |
| ... | ... |
| 19 = air-conditioner/chiller with BLDC compressor | |
| 20 = superheat control with 2 temperature probes | |
| Auxiliary control | Disabled |
| 1 = Disabled | |
| 2 = High condensing temperature protection on S3 | |
| 3 = Modulating thermostat on S4 | |
| 4 = Backup probes on S3 and S4 | |
| 5, 6, 7 = reserved | |
| 8 = Subcooling measurement | |
| 9 = Reverse high condensing temperature protection on S3 | |
| Probe S3 | Ratiometric: -1 to 9.3 barg |
| ... | ... |
| 20 = external signal (4 to 20 mA) (CANNOT BE SELECTED) | |
| Variable 1/2 on the display | Superheat |
| ... | ... |
| 11 = Modulating thermostat temperature | |
| S1 probe alarm management | Valve in fixed position |
| ... | ... |
| Use backup probe S3 | |
| S2 probe alarm management | Valve in fixed position |
| ... | ... |
| Use backup probe S4 | |
| Auxiliary refrigerant | 0 |
| 0 = same as main control; | |
| 1 = R22 | 2 = R134a |
| 3 = R404A | |
| 4 = R407C | 5 = R410A |
| 6 = R507A | |
| 7 = R290 | 8 = R600 |
| 9 = R600a | |
| 10 = R717 | 11 = R744 |
| 12 = R728 | |
| 13 = R1270 | 14 = R417A |
| 15 = R422D | |
| 16 = R413A | 17 = R422A |
| 18 = R423A | |
| 19 = R407A | 20 = R427A |
| 21 = R245FA | |
| 22 = R407F | 23 = R32 |
| 24 = HTR01 | |
| 25 = HTR02 | 26 = R23 |
| 27 = R1234yf | |
| 28 = R1234ze | 29 = R455A |
| 30 = R170 | |
| 31 = R442A | 32 = R447A |
| 33 = R448A | |
| 34 = R449A | 35 = R450A |
| 36 = R452A | |
| 37 = R508B | 38 = R452B |
| 39 = R513A | |
| 40 = R454B | 41 = R458A |

| Parameter/Description | Def. / UoM |
|--|------------|
| CONFIGURATION | |
| PROBES | |
| S3: calibration gain 4 to 20 mA (CANNOT BE SELECTED) | 1 |
| CONTROL | |
| Discharge superheat set point | 35 |
| Discharge temperature set point | 105 |
| SPECIAL | |
| HiTcond: thresh.old | 80 |
| HiTcond: integral time | 20 |
| Modulating thermostat: set point | 0 |
| Modulating thermostat: differential | 0.1 |
| Modulating thermostat: superheat set point offset | 0 |
| ALARM CONFIGURATION | |
| High condensing temperature alarm delay (HiTcond) | 600 |

Tab. 13.b

13.5 Programming with the display

Before setting the parameters, switch the display to driver A.

Important: ignore the parameters for driver B.

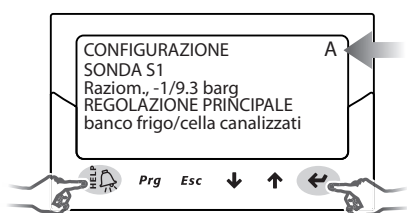

Fig. 13.c

13.6 Auxiliary refrigerant

In the event of cascade systems comprising a main circuit and a secondary circuit, the auxiliary refrigerant is the refrigerant in the secondary circuit. See the paragraphs "Auxiliary control" and "Reverse high condensing temperature protection (HiTcond) on S3". The default value 0 sets the same refrigerant as in the main circuit.

| Parameter/description | Def. | Min | Max | U.M. |
|--|-----------|-------------|-----|------|
| CONFIGURATION | | | | |
| Refrigerant: | R404A | - | - | - |
| -1= user defined; 0= same as main control; | | | | |
| 1= R22 | 2= R134a | 3= R404A | | |
| 4= R407C | 5= R410A | 6= R507A | | |
| 7= R290 | 8= R600 | 9= R600a | | |
| 10= R717 | 11= R744 | 12= R728 | | |
| 13= R1270 | 14= R417A | 15= R422D | | |
| 16= R413A | 17= R422A | 18= R423A | | |
| 19= R407A | 20= R427A | 21= R245FA | | |
| 22= R407F | 23= R32 | 24= HTR01 | | |
| 25= HTR02 | 26= R23 | 27= R1234yf | | |
| 28= R1234ze | 29= R455A | 30= R170 | | |
| 31= R442A | 32= R447A | 33= R448A | | |
| 34= R449A | 35= R450A | 36= R452A | | |
| 37= R508B | 38= R452B | 39= R513A | | |
| 40= R454B | 41= R458A | | | |

Tab. 13.c



Note:

- for cascade CO2 systems, at the end of the commissioning procedure, also set the auxiliary refrigerant. See the paragraph on reverse HiTcond;
- if the refrigerant is not among those available for the "Refrigerant" parameter:
 - set any refrigerant (e.g. R404);
 - select the model of valve, the pressure probe S1, the type of main control and end the commissioning procedure;
 - enter programming mode and set the type of refrigerant: custom, and the parameters "Dew a...f high/low" and "Bubble a...f high/low" that define the refrigerant;
 - start control, for example by closing the digital input contact to enable operation.

13.7 S3 e S4 inputs

The auxiliary probe S3 is associated with the high condensing temperature protection or can be used as a backup probe for the main probe S1. If the probe being used is not included in the list, select any 0 to 5 V ratiometric or electronic 4 to 20 mA probe and then manually modify the minimum and maximum measurement in the manufacturer parameters corresponding to the probes.

Important: probes S3 and S4 are shown as NOT USED if the "auxiliary control" parameter is set as "disabled". If "auxiliary control" has any other setting, the manufacturer setting for the probe used will be shown, which can be selected according to the type.

Priority of digital inputs

In certain cases the setting of digital inputs 1 and 2 may be the same or alternatively may be incompatible (e.g.: digital input 1 = regulation backup, digital input 2 = regulation security). The problem thus arises to determine which function the driver needs to perform.

Consequently, each type of function is assigned a priority, primary (PRIM) or secondary (SEC), as shown in the table:

| DI1/DI2 configuration | Type of function |
|---|------------------|
| 1=Disabled | SEC |
| 2=Valve regulation optimization after defrost | SEC |
| 3=Discharged battery alarm management | SEC |
| 4=Valve forced open (at 100%) | SEC |
| 5=Regulation start/stop | PRIM |
| 6=Regulation backup | PRIM |
| 7=Regulation security | PRIM |

Tab. 13.d

There are four possible cases of digital input configurations with primary or secondary functions.

| Function set | | Function performed by digital input | |
|--------------|------|---|-----|
| DI1 | DI2 | PRIM | SEC |
| PRIM | PRIM | DI1 | - |
| PRIM | SEC | DI1 | DI2 |
| SEC | PRIM | DI2 | DI1 |
| SEC | SEC | Regulation backup (supervisor variable) | DI1 |

Tab. 13.e

Note that:

- if digital inputs 1 and 2 are set to perform a PRIM function, only the function set for input 1 is performed;
- if the digital inputs 1 and 2 are set to perform a SEC function, only the SEC function set for input 1 is performed; the driver will be set to "Regulation backup" with the value of the digital input determined by the "Regulation backup from supervisor" variable.

13.8 Main control – additional functions

The following additional functions are available using probes S3 and S4.

BLDC Control with compressor

Important: this type of control is incompatible with adaptive control and autotuning.

To be able to use this control function, only available for CAREL valve drivers, the driver must be connected to a CAREL pCO programmable controller running an application able to manage a unit with BLDC scroll compressor. In addition, the compressor must be controlled by the CAREL Power+ "speed drive" (with inverter), specially designed to manage the speed profile required by the compressor operating specifications. Two probes are needed for superheat control (PA, TA) plus two probes located downstream of the compressor (PB, TB) for discharge superheat and discharge temperature (TB) control.

| Parameter/Description | Def. |
|---------------------------------|--------------------------------|
| CONFIGURATION | |
| Main control | multiplexed showcase/cold room |
| ... | |
| AC/chiller with BLDC compressor | |

Tab. 13.f

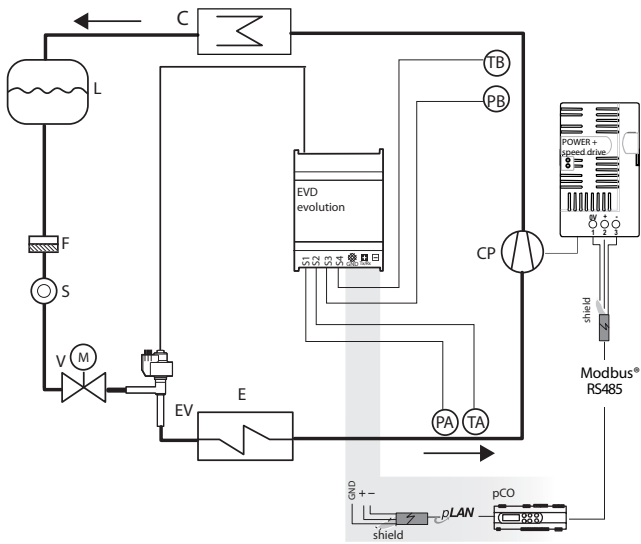

Fig. 13.d

Legenda:

| | | | |
|--------|--------------------|--------|------------------|
| CP | Compressor | V | Solenoid valve |
| C | Condenser | S | Liquid gauge |
| L | Liquid receiver | EV | Electronic valve |
| F | Dewatering filter | E | Evaporator |
| TA, TB | Temperature probes | PA, PB | Pressure probes |

For information on the wiring see paragraph "General connection diagram".

To optimise performance of the refrigerant circuit, compressor operation must always be inside a specific area, called the envelope, defined by the compressor manufacturer.

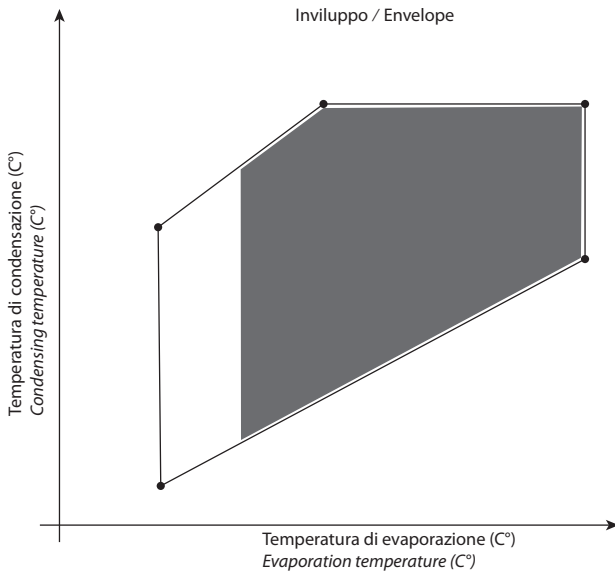

Fig. 13.e

The pCO controller defines the current set point according to the point of operation within the envelope:

- superheat setpoint;
- discharge superheat setpoint;
- discharge temperature setpoint.

| Parameter/Description | Def. | Min. | Max. | UOM |
|--------------------------------|------|------------------|----------|--------|
| ADVANCED | | | | |
| Superheat setpoint | 11 | LowSH: threshold | 180(324) | K(°F) |
| Discharge superheat setpoint | 35 | -40(-72) | 180(324) | K(°F) |
| Discharge temperature setpoint | 105 | -60(-76) | 200(392) | °C(°F) |

Tab. 13.g



Note:

this control function is only available CAREL valve drivers; no set point needs to be configured by the user.

Superheat regulation with 2 temperature probes

"EVD Evolution TWIN" +0300006EN - rel. 2.6 - 31.01.2019

The functional diagram is shown below. This type of control must be used with care, due to the lower precision of the temperature probe compared to the probe that measures the saturated evaporation pressure.

| Parameter/Description | Def. |
|--|--------------------------------|
| CONFIGURATION | |
| Main control | multiplexed showcase/cold room |
| ... | |
| superheat regulation with 2 temperature probes | |

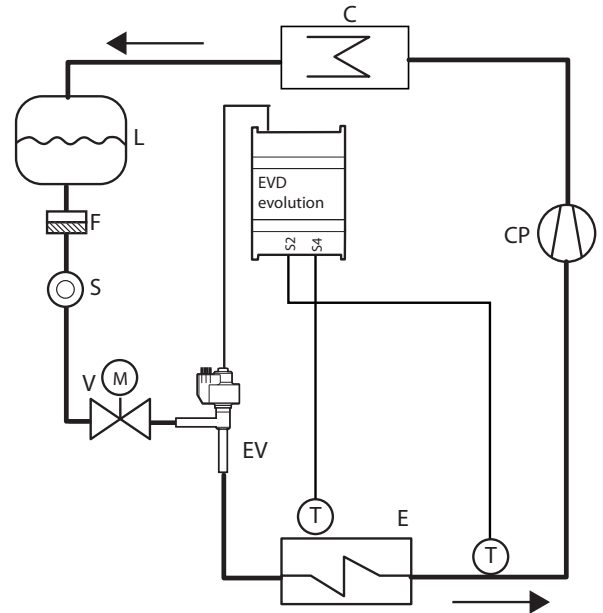

Fig. 13.f

Key:

| | | | |
|----|-------------------|----|------------------|
| CP | Compressor | V | Solenoid valve |
| C | Condenser | S | Liquid gauge |
| L | Liquid receiver | EV | Electronic valve |
| F | Dewatering filter | E | Evaporator |
| T | Temperature probe | | |

| Parameter/Description | Def. | Min. | Max. | U.M. |
|------------------------|------|---------------|-----------|--------|
| ADVANCED | | | | |
| Superheat setpoint | 11 | LowSH: soglia | 180 (324) | K (°F) |
| PID: proportional gain | 15 | 0 | 800 | - |
| PID: integral time | 150 | 0 | 1000 | s |
| PID: derivative time | 5 | 0 | 800 | s |

Tab. 13.h

13.9 Auxiliary control

Auxiliary control can be activated at the same time as main control, and uses the probes connected to inputs S3 and/or S4.

| Parameter/description | Def. |
|--|----------|
| CONFIGURATION | |
| Auxiliary control: | Disabled |
| 1=Disabled; | |
| 2=High condensing temperature protection on S3 probe; | |
| 3=Modulating thermostat on S4 probe; | |
| 4=Backup probes on S3 & S4; | |
| 5, 6, 7 = Reserved; | |
| 8 = Subcooling measurement; | |
| 9 = Reverse high condensing temperature protection on S3 | |

Tab. 13.i

For the high condensing temperature protection (only available with superheat control), an additional pressure probe is connected to S3 that measures the condensing pressure. For the modulating thermostat function (only available with superheat control), an additional temperature probe is connected to S4 that measures the temperature on used to perform temperature control (see the corresponding paragraph).

The last option (available if "main control" = 1 to 18) requires the installation of both probes S3 & S4, the first pressure and the second temperature.

Note: if only one backup probe is fitted, under the manufacture parameters, the probe thresholds and alarm management can be set separately.

HITCond protection (high condensing temperature)

The functional diagram is shown below.

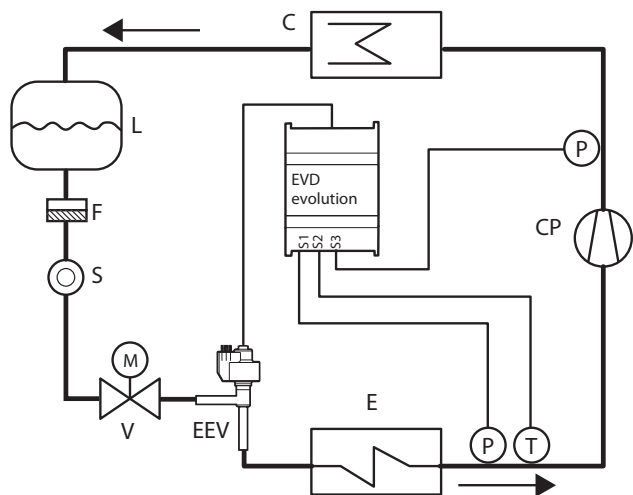

Fig. 13.g

Key:

| | | | |
|----|-------------------|-----|-----------------------------|
| CP | Compressor | EEV | Electronic expansion valve |
| C | Condenser | V | Solenoid valve |
| L | Liquid receiver | E | Evaporator |
| F | Dewatering filter | P | Pressure probe (transducer) |
| S | Liquid indicator | T | Temperature probe |

For the wiring, see paragraph "General connection diagram".

As already mentioned, the HITCond protection can only be enabled if the controller measures the condensing pressure/temperature, and responds moderately by closing the valve in the event where the condensing temperature reaches excessive values, to prevent the compressor from shutting down due to high pressure. The condensing pressure probe must be connected to input S3.

| Parameter/description | Def. | Min. | Max. | UOM |
|--|------|-----------|-----------|---------|
| ADVANCED | | | | |
| High Tcond threshold | 80 | -60 (-76) | 200 (392) | °C (°F) |
| High Tcond integration time | 20 | 0 | 800 | s |
| ALARM CONFIGURATION | | | | |
| High condensing temperature alarm timeout (High Tcond) (0= alarm DISABLED) | 600 | 0 | 18000 | s |

Tab. 13.j

The integration time is set automatically based on the type of main control.

Note:

- the protector is very useful in units with compressors on board if the air-cooled condenser is undersized or dirty/malfunctioning in the more critical operating conditions (high outside temperature);
- the protector has no purpose in multiplexed systems (showcases), where the condensing pressure is maintained constant and the status of the individual electronic valves does not affect the pressure value.

To reduce the condensing temperature, the output of the refrigeration unit needs to be decreased. This can be done by controlled closing of the electronic valve, implying superheat is no longer controlled, and an increase in the superheat temperature. The protector will thus have a moderate reaction that tends to limit the increase in the condensing temperature, keeping it below the activation threshold while trying to stop the superheat from increasing as much as possible. Normal operating conditions will not resume based on the activation of the protector, but rather on the reduction in the outside temperature. The system will therefore remain in the best operating conditions (a little below the threshold) until the environmental conditions

change.

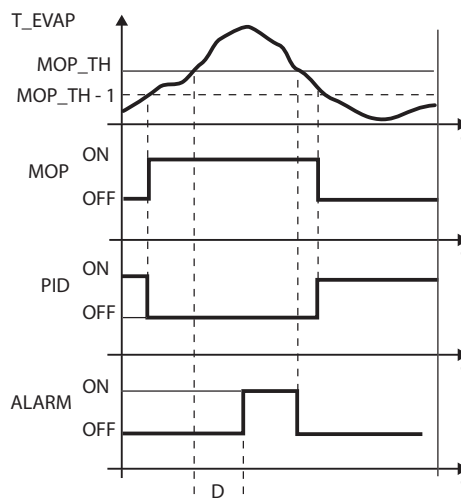

Fig. 13.h

Key:

| | | | |
|---------|------------------------------|-----------|--------------------|
| T_COND | Condensing temperature | T_COND_TH | HiTcond: threshold |
| HiTcond | High Tcond protection status | HiTcond | ALARM Alarm |
| PID | PID superheat control | t | Time |
| D | Alarm timeout | | |

Note:

- the High Tcond threshold must be greater than the rated condensing temperature of the unit and lower than the calibration of the high pressure switch;
- the closing of the valve will be limited if this causes an excessive decrease in the evaporation temperature.

Modulating thermostat

This function is used, by connecting a temperature probe to input S4, to modulate the opening of the electronic valve so as to limit the lowering of the temperature read and consequently reach the control set point. This is useful in applications such as the multiplexed cabinets to avoid the typical swings in air temperature due to the ON/OFF control (thermostatic) of the solenoid valve. A temperature probe must be connected to input S4, located in a similar position to the one used for the traditional temperature control of the cabinet. In practice, the closer the controlled temperature gets to the set point, the more the control function decreases the cooling capacity of the evaporator by closing the expansion valve. By correctly setting the related parameters (see below), a very stable cabinet temperature can be achieved around the set point, without ever closing the solenoid valve. The function is defined by three parameters: set point, differential and offset.

| Parameter/description | Def. | Min. | Max. | UOM |
|---|------|-----------|-----------|---------|
| ADVANCED | | | | |
| Modul. thermost setpoint | 0 | -60 (-76) | 200 (392) | °C (°F) |
| Modul. thermost differential | 0.1 | 0.1 (0.2) | 100 (180) | °C (°F) |
| Modul. thermost SHset offset (0= function disabled) | 0 | 0 (0) | 100 (180) | K (°R) |

Tab. 13.k

The first two should have values similar to those set on the controller for the cabinet or utility whose temperature is being modulated. The offset, on the other hand, defines the intensity in closing the valve as the temperature decreases: the greater the offset, the more the valve will be modulated. The function is only active in a temperature band between the set point and the set point plus the differential.

Important: the "Modulating thermostat" function should not be used on stand-alone refrigeration units, but only in centralised systems. In fact, in the former case closing the valve would cause a lowering of the pressure and consequently shut down the compressor.

Examples of operation:

1. offset too low (or function disabled)

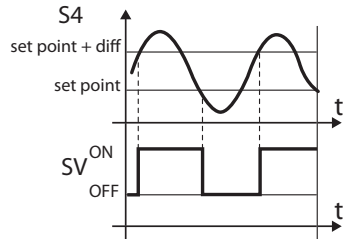

2. offset too high

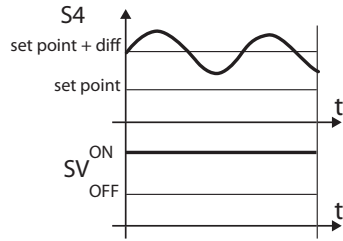

3. offset correct

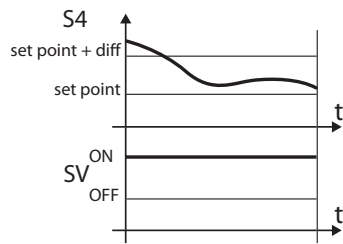

Fig. 13.i

Key:

diff= differential
SV= solenoid valve (showcase temperature control)
S4= temperature

Backup probes on S3 & S4

Important: this type of control is compatible with the "main control" parameter setting between 1 and 18.

In this case, pressure probe S3 and temperature probe S4 will be used to replace probes S1 and S2 respectively in the event of faults on one or both, so as to guarantee a high level of reliability of the controlled unit.

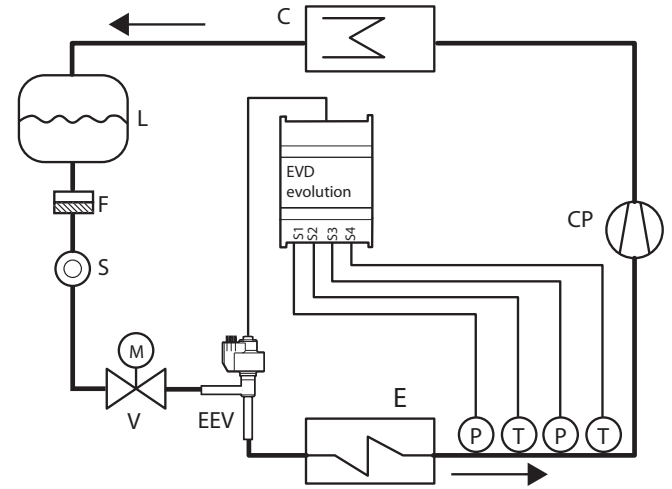

Fig. 13.k

Key:

| | | | |
|----|-------------------|-----|-----------------------------|
| CP | Compressor | EEV | Electronic expansion valve |
| C | Condenser | V | Solenoid valve |
| L | Liquid receiver | E | Evaporator |
| F | Dewatering filter | P | Pressure probe (transducer) |
| S | Liquid indicator | T | Temperature probe |

For the wiring, see paragraph "General connection diagram".

Subcooling measurement

This function measures subcooling using a pressure probe and a temperature probe connected to inputs S3 and S4 respectively. The reading can be sent to a controller connected in the serial network (e.g. pCO).

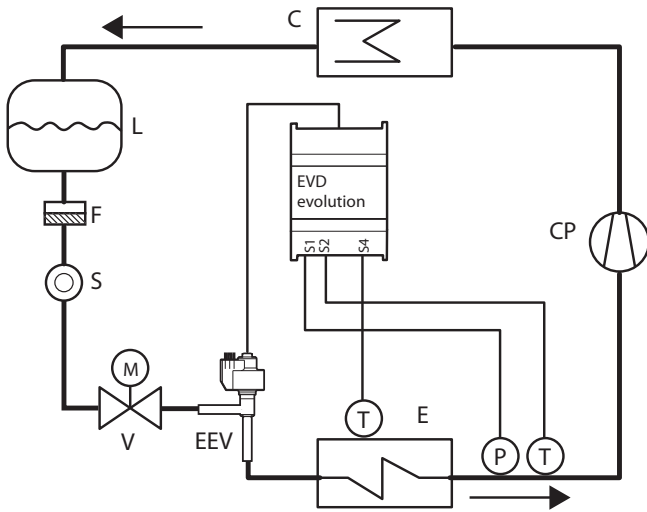

Fig. 13.j

Key:

| | | | |
|----|-------------------|-----|-----------------------------|
| CP | Compressor | EEV | Electronic expansion valve |
| C | Condenser | V | Solenoid valve |
| L | Liquid receiver | E | Evaporator |
| F | Dewatering filter | P | Pressure probe (transducer) |
| S | Liquid indicator | T | Temperature probe |

For the wiring, see paragraph "General connection diagram".

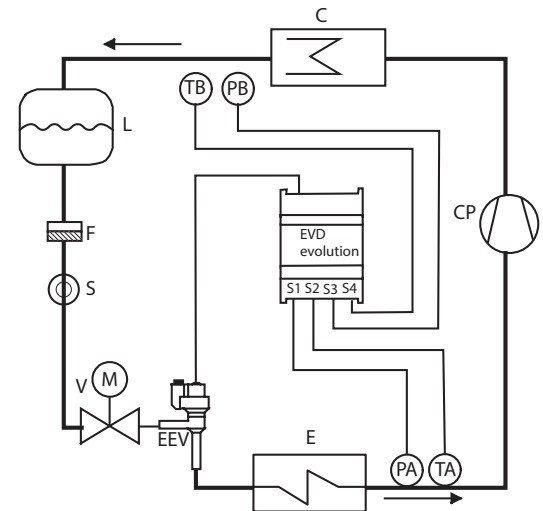

Fig. 13.l

Key:

| | | | |
|----|-----------------|--------|----------------------------|
| CP | Compressor | EEV | Electronic expansion valve |
| C | Condenser | V | Solenoid valve |
| L | Liquid receiver | E | Evaporator |
| F | Filter-drier | PA, PB | Pressure probes |
| S | Liquid gauge | TA, TB | Temperature probes |

For the wiring, see paragraph "General connection diagram".

The subcooling measurement uses the difference between the condensing temperature taken from the relative pressure reading and the temperature of the liquid refrigerant exiting the condenser. This measurement indicates the refrigerant charge in the circuit.

A value near 0 K indicates possible insufficient refrigerant, which may cause a decline in circuit cooling efficiency, a reduction in mass flow through the expansion valve and swings in superheat control. In addition, it may indicate a refrigerant leak in circuits where the nominal subcooling value is known.

A subcooling value that is too high, for example above 20 K, when not required by the application may indicate excessive refrigerant charge in the circuit, and can cause unusually high condensing pressure values with a consequent decline in circuit cooling efficiency and possible compressor shutdown due to the high pressure switch tripping.

Reverse high condensing temperature protection (HiTcond) on S3

The aim of reverse HiTcond protection is to limit the condensing pressure in the refrigerant circuit by opening the valve rather than closing it. This function is recommended, rather than the HiTcond protection function described previously, in refrigerant circuits without a liquid receiver and where the condenser is smaller than the evaporator (e.g. air-to-water heat pumps). In this case, in fact, closing the valve would obstruct the flow of refrigerant to the condenser that, lacking sufficient volume for the refrigerant to accumulate, would cause an increase in condensing pressure. This function is especially useful for condensers in CO₂ cascade systems. See the chapter on Protectors.

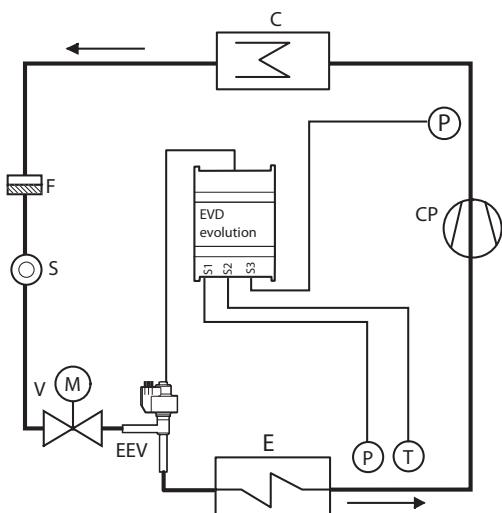

Fig. 13.m

Key:

| | | | |
|----|-------------------|-----|-----------------------------|
| CP | Compressor | EEV | Electronic expansion valve |
| C | Condenser | V | Solenoid valve |
| F | Filter-drier | E | Evaporator |
| S | Liquid gauge | P | Pressure probe (transducer) |
| T | Temperature probe | | |

For the wiring, see paragraph "General connection diagram"

Important: opening the valve will probably also cause activation of the low superheat protection LowSH, which tends to limit the opening of the valve. The ratio between the integral times of these two concurrent yet opposing protectors determines how effective one is compared to the other.

Reverse HiTcond (for CO₂ cascade systems)

Reverse high condensing temperature protection (HiTcond) on S3 is especially useful for condensers in CO₂ cascade systems, where condensation in the low temperature circuit (also called "secondary", B) takes place when evaporating the refrigerant in the medium temperature circuit ("primary", A).

| Parameter / Description | Def. |
|-------------------------|------------------------------|
| SPECIAL | |
| Refrigerant | Alls refrigerants, not R744 |
| Main regulation | Subcooling regulation 1...10 |
| Auxiliary refrigerant | R744 |

Tab. 13.I

Nota: for this type of application, the auxiliary refrigerant must be set as CO₂ (R744).

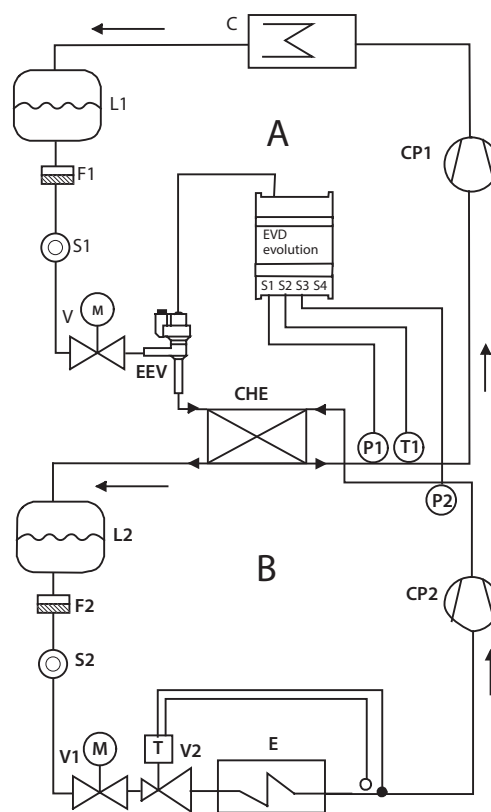

Fig. 13.n

Key:

| | | | |
|-------|------------------------|------|------------------------------|
| CP1/2 | Compressor 1/2 | EEV | Electronic expansion valve |
| CHE | Cascade heat exchanger | C | Condenser |
| L1/2 | Liquid receiver 1/2 | V | Solenoid valve |
| F1/2 | Filter-drier 1/2 | E | Evaporator |
| S1/2 | Liquid gauge 1/2 | P1/2 | Pressure probe (transducer) |
| T1 | Temperature probe | V2 | Thermostatic expansion valve |

For the wiring, see paragraph 2.11 "General connection diagram"

The driver controls refrigerant superheat in the primary circuit (A), and at the same time measures the refrigerant condensing pressure in the secondary circuit (B). When the condensing temperature exceeds the HiTCond protection threshold, normal superheat control is overridden by forced opening of the valve, at a rate that is inversely proportional to the HiTCond protection integral time. Opening the EEV lowers the superheat in the primary circuit, which increases the heat exchange coefficient and consequently reduces the condensing pressure in the secondary circuit.

The reverse HiTcond threshold for CO₂ cascade applications should be set in relation to the expected evaporation temperature in the primary circuit. The threshold must be set to a value that is at least 3-5°C higher than the minimum evaporation temperature in the primary circuit. Lower values make achieving the set pressure limit incompatible with heat exchange efficiency. In addition, swings in operation may occur due the attempt to limit low superheat in the primary circuit and the pressure in the secondary circuit at the same time.

13.10 Variables used based on the type of control

Vedere il manuale cod. +0300005IT.

CAREL

CAREL INDUSTRIES HQs
Via dell'Industria, 11 - 35020 Brugine - Padova (Italy)
Tel. (+39) 049.9716611 - Fax (+39) 049.9716600
e-mail: carel@carel.com - www.carel.com

Agenzia / Agency: