



Refrigeration Scroll

ZF24 K4E...ZF48 K4E
ZS56 K4E...ZS11 M3E
ZB56 KCE...ZB11 MCE

Application Guidelines



EMERSON
Climate Technologies

Contents.....	2
1. Introduction.....	3
2. Nomenclature.....	3
3. Qualified Refrigerants.....	3
4. Lubrication.....	4
5. Refrigerant Injection.....	5
6. Screens.....	6
7. Crankcase Heaters.....	6
8. Pump down.....	6
9. Pressure Controls.....	6
10. Mufflers.....	7
11. Shell Temperature.....	7
12. Deep Vacuum Operation.....	7
13. Shut off Sound.....	7
14. Brief Power Interruptions.....	7
15. Discharge Temperature Protection.....	7
16. Electronic Protection.....	8
17. Phase Protection.....	9
18. Protector Functional Check and Failure Detection.....	9
19. Electrical Installation.....	10
20. Electrical Connections.....	10
21. Cable Connectors.....	11
22. Suction Line Noise and Vibration.....	11
23. Compressor Functional Check.....	12
24. High Potential Testing.....	13
25. Installation.....	13
26. System Evacuation and Charging Procedure.....	14
27. Starting.....	14
28. Rotation Direction.....	14
29. Shut-off Valves and Adaptors.....	15
30. Unbrazing System Components.....	16
31. Compressor Replacement.....	16
32. Pressure Equipment Directive.....	16
33. Application Envelopes.....	17
34. ZB/ZS Comparisons.....	19
35. Motor Codes.....	19



1. Introduction

This Guideline describes the operating characteristics, design features, and application requirements for 7.5 to 15 HP Refrigeration Scroll Compressors. Typical model numbers are ZF40K4E-TWD, ZS 92K4E-TWD and ZB11MCE-TWD. This family of scroll compressors is characterised by the pilot duty motor protection system that uses internal sensors and an external electronic module to protect the compressor against motor overheating and excessive discharge temperature. For additional information, please refer to the “Product Catalogue” or to the “Copeland Selection Software” accessible from the Copeland Website at www.ecopeland.com. There are several operating characteristics and design features described below that are different from those of the smaller Copeland Scroll compressor models. These guidelines are not meant to replace the system expertise available from system manufactures.

2. Nomenclature

The model numbers of Copeland Scroll compressors have been designed to include a coded nominal capacity at ARI operating conditions in BTU/h at 60 Hz. All refrigeration scroll compressors are charged with Ester oil, which is indicated by the letter “E”.

Model Designation

Z F 3 3 K 4 E - T W D - 5 5 1
1 2 3 4 5 6 7

- 1 Z = Compressor family: Z = Scroll
- 2 S = High/Medium Temperature
F = Low Temperature
B = High/Medium Temperature
- 3 Nominal capacity [BTU/h] @ 60 Hz and ARI conditions using multipliers
"K" for 1000 and "M" for 10 000
- 4 - Model variation
- 5 - POE oil
- 6 - Motor version
- 7 - Bill of material number

551: Rotalock threaded stubs, oil sight glass, schraeder connection for oil fill or drain.

3. Qualified Refrigerants

R22, R404A, R507 and R134a are qualified for all refrigeration scroll compressors.

The ZB compressor family is also qualified for R407C.

It is essential that the glide of R 407C refrigerant blends be given careful consideration when adjusting pressure controls.

The application envelopes for each refrigerant are shown in section 33

4. Lubrication

The oil level should be maintained at midpoint of the sight glass. If an oil regulator is being used the level should be set within the top half of the sight glass (for parallel operation please refer to guidelines C6.2.5/0901-0702/E).

The compressor is supplied with an initial oil charge. The standard oil charge is a Polyolester (POE) lubricant ICI Emkarate 32 CF (32 cSt). In the field, the oil level could be topped up with ICI Emkarate RL 32 CF or Mobil EAL Arctic 22 CC. The values can be taken from Copeland's brochure or Selection Software Program.

The compressors must be operated with these specific oils only. Under no circumstances are ester oils to be mixed with mineral oil and/or alkyl benzene when used with chlorine-free refrigerants.

Ester oil behaves extremely hygroscopically (see Figure 1), and this influences the chemical stability of the oil.

The number of start/stop cycles should be limited to 10 per hour. A high cycling rate will pump oil into the system and may lead to lubrication failure. Oil leaves the compressor at start up regardless of the low oil carry over of the Scroll. The short running time is insufficient to return the oil to the compressor and possibly results in a lack of lubricant.

It must be considered that the entire system will be coated with oil to some extent. Oil viscosity changes with temperature. System gas velocity changes depending on temperature and load. In low load conditions gas velocity may not be high enough to return oil to the compressor. System piping should be designed to return oil under all operating conditions

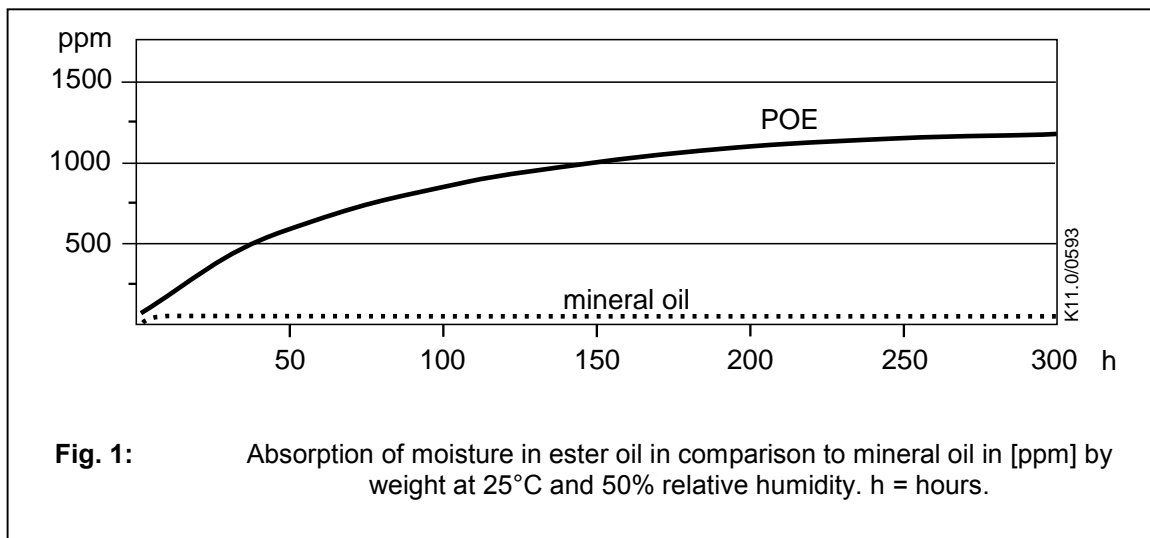

The system should be evacuated down to 0.3 mbar/ 0.22 Torr or lower. If there is uncertainty, as to the moisture content in the system, an oil sample should be taken from various points and tested for moisture. The residual moisture in the installation should be brought below 50 PPM (please refer to section 26 system evacuation and charging procedure) and the use of a suitable filter drier (solid core XH9 or higher is recommended).

Sight glass/moisture indicators currently available can be used with the HFC refrigerants and lubricants; however, the moisture indicator will just show the moisture contents of the refrigerant.

The actual moisture level of POE would be higher than the sight glass specifies. This is a result of the high hygroscopicity of the POE oil.

As POE oil is very hygroscopic, it is recommended that the plugs in the compressor line connections be left in place until the compressor is set into position.

5. Refrigerant Injection

For low temperature applications of ZF models liquid or vapour injection is required to keep discharge gas temperatures within safe limits.

The compressor is supplied with a 1/4" diameter injection stub to accept a capillary tube. Injection takes place into two distinct pockets of the spirals without influencing the suction process, injection increase the mass flow through the condenser.

Vapour injection by utilisation of an economiser, subcools liquid to the evaporator, increasing system performance (see Figure 3). The vapour injection cools the compressed refrigerant gas and extends the operating envelope (See section 33). Best subcooling effect is assured if counter flow of gas and liquid is provided as shown. In order to guarantee proper oil transport gas should exit the economiser at the bottom. This is especially true for plate heat exchangers, which have to be mounted upright.

Liquid injection provides a further extension of the operating envelope over vapour injection as can be observed in the Application Envelopes (section 33).

Liquid injection takes place directly with the capillary tube as shown in Figure 2.

The cap tube is needed to meter the proper amount of liquid refrigerant into the compressor for liquid injection or vapour injection for use with the economiser.

It consists of a wrapped capillary tube inside a shell. It is supplied with a clamp to support the assembly at the injection port. In case this assembly is not desired but an own device has to be built, please take the specifications out of Table 1.

A standard on-off solenoid valve, such as ALCO 110 RB 2T2, should be used. The valve should have a port diameter of at least 1.4mm and should be wired to open when the compressor is running and to close

- when compressor shuts off
- during a hot gas defrost
- during a pump down cycle.

A filter drier, such as ALCO ADK-Plus 036MMS or ADK-Plus 032S, should be installed before the solenoid valve to avoid clogging of the valve and the injection device.

If the internal motor protector trips, power to the injection solenoid must be dropped.

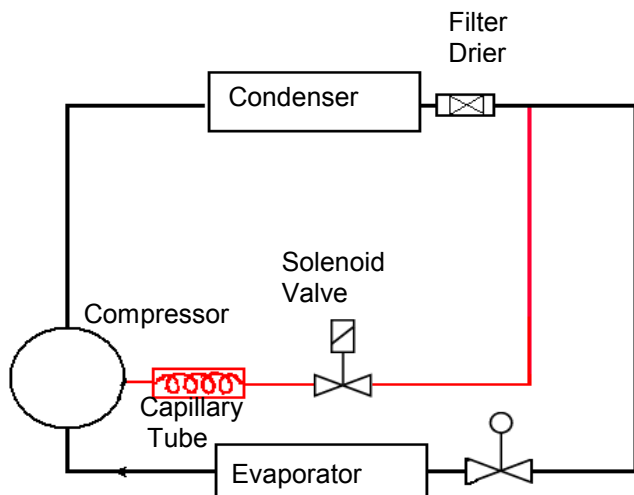

Fig .2 Liquid Injection

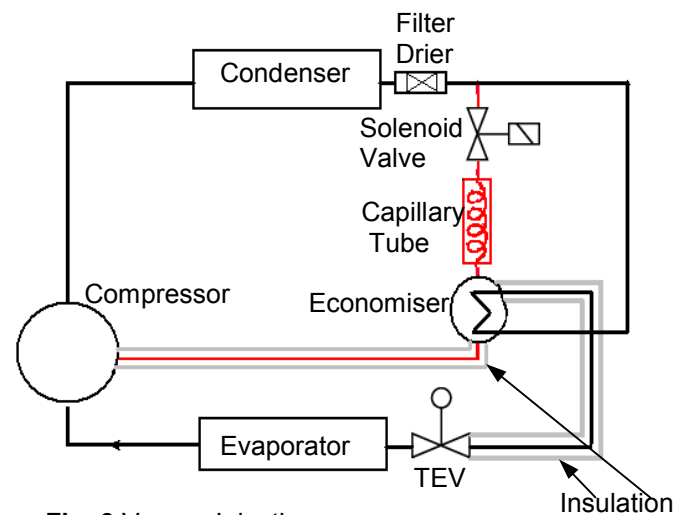

Fig .3 Vapour Injection

Table 1

Model	R404A/R507		R22	
	I.D. Inch	Length Inch	I.D. Inch	Length Inch
ZF24K4E	0.050"	30"	0.050"	5"
ZF33K4E	0.050"	17.5"	0.050"	5"
ZF40K4E	0.070"	30"	0.070"	30"
ZF48K4E	0.07"	30"	0.07"	10"

6. Screens

The use of screens finer than 30 x 30 mesh (0,6 mm² openings) anywhere in the system is not recommended. Field experience has shown that finer mesh screens used to protect thermal expansion valves, capillary tubes, or accumulators could become temporarily or permanently plugged. Such blockage can result in compressor failure.

7. Crankcase Heaters

Equipment for heating the oil in the crankcase is necessary if the system configuration enables large amounts of refrigerant to condense in the compressor and be absorbed by the oil. At the high temperature produced by the heater refrigerant is constantly vaporised and problems in oil supply are reduced. For correct mounting location of such a heater, please see Figure 4.

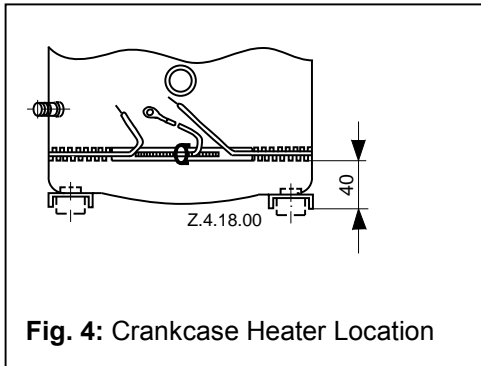

Fig. 4: Crankcase Heater Location

The crankcase heater must be mounted below the oil removal valve located on the bottom shell. The crankcase heater must remain energized during compressor off cycles.

The initial start in the field is a very critical period for any compressor because all load bearing surfaces are new and require a short break-in period to carry high loads under adverse conditions.

Due to the Compliant Scroll's inherent ability to handle liquid refrigerant in flooded conditions, no crankcase heater is required when the system charge does not exceed 7.5 kg. If a crankcase heater is fitted, it is recommended the heater must be turned on for a

minimum of 12 hours prior to starting the compressor. This will prevent oil dilution and bearing stress on initial start up.

8. Pump down

To control refrigerant migration a pump down system could be used. The discharge check valve with refrigeration scroll compressor is designed for low leak back and will allow the use of a pump down without the addition of an external check valve.

If the compressor is stationary for prolonged periods, refrigerant could migrate into the compressor and therefore a crankcase heater must be installed.

If constant cold air is drawn over the compressor, this could make the crankcase heater ineffective, and therefore a pump down system is recommended.

9. Pressure Controls

Both high and low pressure controls are required and the following working pressures are recommended:

For ZF models, the normal minimum setting should be 0.3 bar g (R404A), 0.0 bar g (R22). Maximum is 28 bar g.

For ZS and ZB models, the LP cut out should be set as high as possible. The normal minimum is 2.6 bar g.

The high pressure maximum is 28 bar g. for all types



10. Mufflers

Flow through Copeland Scroll Compressors is semi-continuous with relatively low pulsation. External mufflers, where they are normally applied to piston compressors today, may not be required for Copeland Scroll. Because of variability between systems, however, individual system tests should be performed to verify acceptability of sound levels.

11. Shell Temperature

Certain types of system failures, such as condenser or evaporator fan blockage or loss of charge may cause the top shell and discharge line to briefly but repeatedly reach temperatures above 177°C as the compressor cycles on its internal protection devices. Care must be taken to ensure that wiring or other materials, which could be damaged by these temperatures, do not come in contact with these potentially hot areas.

12. Deep Vacuum Operation

Do not run a "refrigeration scroll" compressor in a deep vacuum. Failure to heed this advice can result in arcing of the Fusite pins causing permanent damage to the compressor.

A low pressure control is required for protection against deep vacuum operation (see section 9).

13. Shut off Sound

Scroll compressors may run backward for a brief period at shut off as the internal pressures equalise. A low mass, disc-type check valve in the discharge tube of the compressor prevents high pressure gas entering the compressor after shut down. Additionally there is a dynamic discharge valve mounted on the fixed Scroll, which effectively eliminates reverse rotation.

14. Brief Power Interruptions

No time delay is required on three phase models to prevent reverse rotation due to power interruptions. The torque of the motor is strong enough to assure proper rotation under all starting circumstances.

15. Discharge Temperature Protection

A thermistor with a nominal response temperature of 140 °C is located in the discharge port of the fixed scroll (Figure 5). Excessive discharge temperature will cause the electronic protector module to trip (see also section 15). The discharge gas sensor is wired in series with the motor thermistor chain.

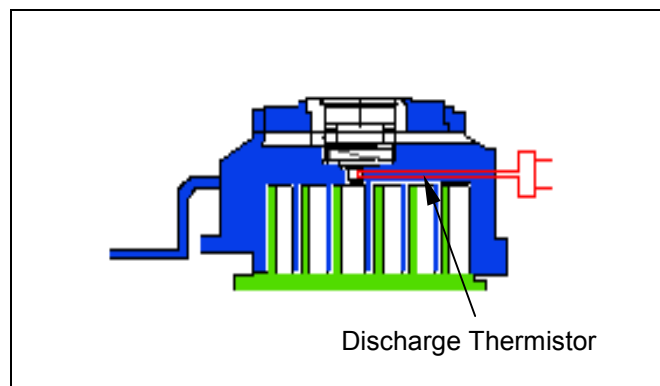
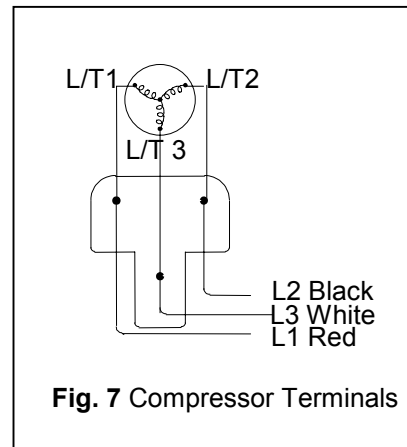
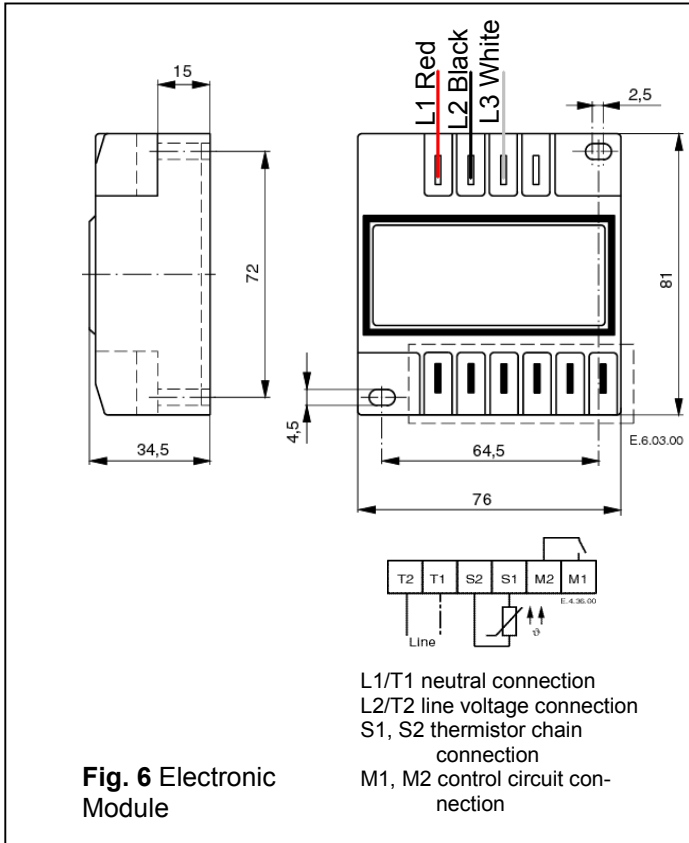

Figure 5 Discharge Thermistor Position

16. Electronic Protection

The electronic protection system as used in all 7.5HP to 15.0HP refrigeration scroll compressors is identified by a "W" as the centre letter in the motor code. This system utilises the temperature dependent resistance of thermistors (also called PTC-resistances) to read the winding temperature. A chain of four thermistors connected in series is embedded in the motor windings so that the temperature of the thermistors can follow the winding temperature with little inertia. An electronic module (INT69SCY) is required to process the resistance values and trip a control relay depending on the thermistor resistance. The characteristic gradient of a thermistor resistance curve is shown in Figure 8. The resistance curve can be designed for different operating points, the nominal response temperature (NAT), e.g. 80°C, 100°C, 140°C, and must comply with the tolerances laid out in the standard DIN 44081.



Protector Specifications

Type	INT69 SCY
Voltage	120/240V AC
Normal PTC resistance	250 to 1000 Ohms
Trip resistance	>4500 Ohm ±
Reset resistance	<2750 Ohms
Module time out	30 minutes ± 5 Min.
Phase monitor:	Yes

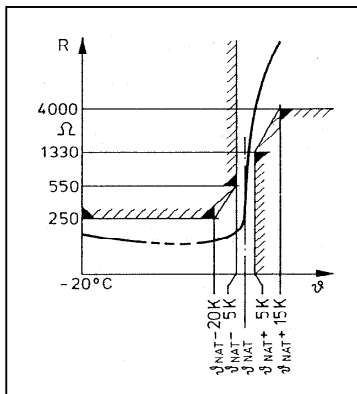

For protection in case of blocked rotor one thermistor for each phase is embedded in the winding heads on the upper (suction gas) side of the compressor motor.

A fourth thermistor is located in a winding head at the lower end of the motor. A fifth sensor is located in the discharge port of the fixed scroll to control discharge gas superheat. The entire chain is internally led to the fusite from where it is connected to the module connections S1 and S2 (see Fig. 6). When any resistance of the thermistor chain reaches the tripping value, the module interrupts the control line and causes the compressor to switch off. After the thermistor has cooled sufficiently, its resistance drops to the reset value but the module itself, however, resets after a time delay of 30 minutes.

Fig. 8 Thermistor Resistances



17. Phase Protection

The phase protection capabilities of the INT69SCY module will sense the correct phase sequence of L1, L2, and L3 incoming power. Three phase power must be wired in the correct phase sequence that will ensure the compressor will start and operate in the correct rotation. When the INT. 69SCY trips on phase loss a delay of 5 minutes is activated. If all three phases are present then the compressor will continue to run, if not the module will lock out.

After 10 attempts to restart the compressor, the module will lock out, which could be reset by re-establishing incoming power to the module (See Figure 6 and 7).

18. Protector Functional Check and Failure Detection

Prior to start-up of the compressor a functional check shall be carried out:

- Switch off power!
- Disconnect one terminal either S1 or S2 of the electronic module. If the compressor is now switched on, the motor should not start.
- Switch off power.
- Reconnect the disconnected thermistor line. If the compressor is now switched on the motor must start.

Protector Fault Diagnosis:

If the motor does not start-up during the functional check, this indicates a disturbance in operation:

- Switch off power.
- Verify correct phase lead operation (See Figure 7).
- Check the connection of the thermistor leads in the terminal box and at the protection module for possible loose connections and check the connection cable for possible breakage.
- The resistance of the thermistor chain shall be measured in a cold condition; i.e. after the motor has sufficiently cooled down.

Caution: Use maximum measuring voltage of 3 V!

In doing so, the thermistor leads at terminals S1 and S2 of the module shall be disconnected and measured between the leads. Resistance must be between 250 and 1250 ohms at room temperature.

The trip resistance is 10,000 ohms or higher and the reset resistance is 3000 ohms \pm 500 ohms.

If the resistor is 0 ohms, the compressor has to be exchanged due to shorted sensor circuit. ∞ Ohms indicate an open sensor circuit and the compressor has to be replaced.

If no defect is located in the thermistor chain or there is no loose contact or conductor breakage, the module shall be checked. Then the control connections at M1 and M2 have to be removed (Caution! Switch off voltage supply first!) and check the switching conditions by an ohmmeter or signal buzzer:

- short-cut the already disconnected (see above) thermistor contactors and switch on the voltage supply; the relay must switch; connection established between contactors M1 and M2
- remove the jumper between S1 and S2, the relay must switch off; no connection between contactors M1 and M2
- shortcut the contactors S1 and S2 again, the relay remains switched off; no connection between contactors M1 and M2
- switch off the voltage supply for approximately 4 sec and switch it on again, the relay must switch on now; connection between contactors M1 and M2

If one of the above conditions is not met, the module is defective and has to be exchanged.

Note: The power should be switched off between the tests, in order to avoid short circuits and accidental touching of contacts. The function of the module should be tested each time the fuse in the control circuit breaks the power supply. This makes sure that the contacts did not stick.

19. Electrical Installation

Independently from the internal motor protection, fuses have to be installed before the compressor. Selection of fuses has to be carried out according to VDE 0635 or DIN 57635 or IEC 269-1 or EN 60-269-1.

Motor insulation material class is "H" for models for all refrigeration scroll compressors, according to IEC 34-18-1, EN 0530, VDE 0530 or DIN 57530.

The Fusite connections are marked as in Fig. 10. Recommended wiring diagram is shown in Fig. 11.

20. Electrical Connections

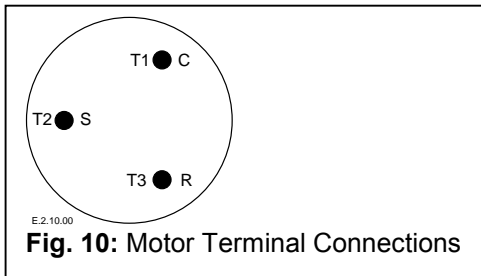

The orientation of the electrical connections on the Copeland Scroll compressors is shown in Fig. 10 and is shown on the wiring diagram inside the terminal box cover. The screw terminals used on this compressor should be fastened with a torque of 2.5 to 2.6 Nm.

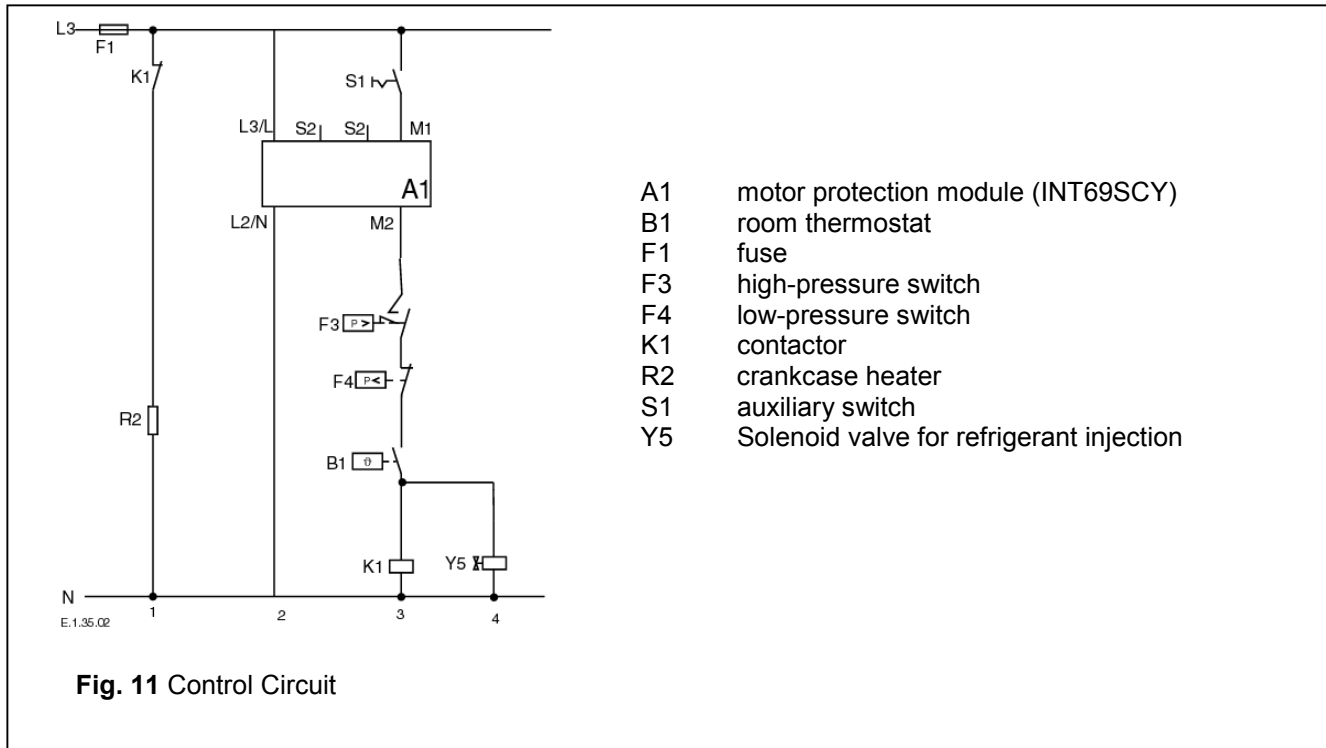

21. Cable Connectors

The following table lists recommended types of cable connectors to be used for the various electric terminals of the compressors and the motor protection module. "A" and "B" must fit 1/4" or 6.3 mm tab sizes. "C" is to be selected for #10 studs.

Model	TW*	Module
ZF24/ZS56/ZB56	B/C	A
ZF33/ZS75/ZB75	B/C	A
ZF40/ZS92/ZB92	B/C	A
ZF48/ZS11/ZB11M	B/C	A

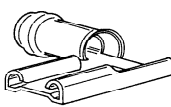

A Flag receptacle

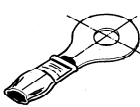

B Ring Tongue



C Spade

1. Fig. 12: Cable connectors

Cable sizes are to be selected according to DIN ISO 0100, IEC 364 or national regulations.

22. Suction Line Noise and Vibration

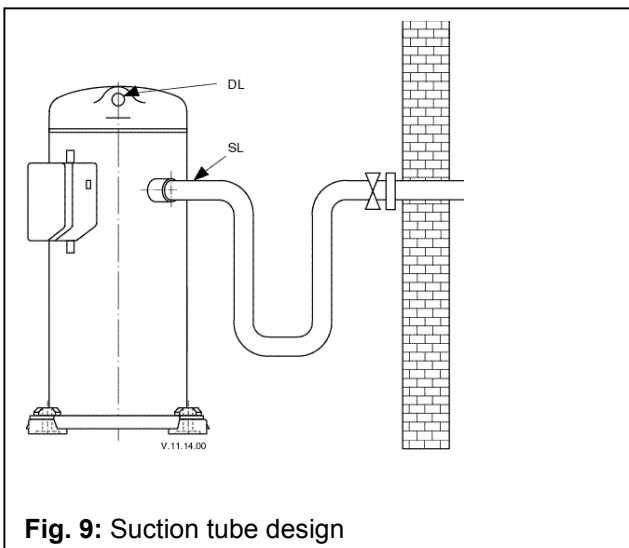

Copeland Compliant Scroll compressors inherently have low sound and vibration characteristics. However, in some respects, the sound and vibration characteristics differ from reciprocating compressors and, in rare instances, could result in unexpected sound complaints. One difference is that the vibration characteristic of the Scroll compressor, although low, includes two very close frequencies, one of which is normally isolated from the shell by the suspension of an internally suspended compressor. These frequencies, which are present in all compressors, may result in a low level "beat" frequency, which can be detected as noise coming along the suction line into a building under some conditions. Elimination of the "beat"

can be achieved by attenuating either of the contributing frequencies. This is easily done by using one of the common combinations of design configuration described below.

A second difference of the Compliant Scroll compressor is that under some conditions the normal starting motion of the compressor can transmit an "impact" noise along the suction line. This phenomenon, like the one described above, also results from the lack of internal suspension, and can be easily avoided by using standard line isolation techniques as described below.

Recommended configuration (fig.9):

- Tubing configuration: small shock loop
- Service valve: "angled valve" fastened to unit/wall
- Suction muffler: not required

Alternative configuration:

- Tubing configuration: small shock loop



Service valve: "straight-through" valve fastened to unit/wall

- Suction muffler: may be required

23. Compressor Functional Check

A functional compressor test with the suction service valve closed to check how low the compressor will pull suction pressure is not a good indication of how well a compressor is performing.

Such a test will damage a scroll compressor. The following diagnostic procedure should be used to evaluate whether a Copeland Scroll compressor is working properly.

1. Proper voltage to the unit should be verified.
2. The normal checks of motor winding continuity and short to ground should be made to determine if an internal motor short or ground fault has developed. If the protector has opened, the compressor must be allowed to cool sufficiently to allow it to reset.
4. With service gauges connected to suction and discharge pressure fittings, turn on the compressor. If suction pressure falls below normal levels, the system is either low on charge or there is a flow blockage in the system.

To test if the compressor is pumping properly, the compressor current draw must be compared to published compressor performance curves using the operating pressures and voltage of the system. If the average measured current deviates more than $\pm 15\%$ from published values, a faulty compressor may be indicated. A current imbalance exceeding 15% of the average on the three phases may indicate a voltage imbalance and should be investigated further.

Before replacing or returning a compressor: Be certain that the compressor is actually defective. As a minimum, recheck a compressor for Hipot, winding resistance, and ability to start before returning. More than one-third of compressors returned to Copeland for warranty analysis are determined to have nothing found wrong. They were miss-diagnosed in the field as being defective. Replacing working compressors unnecessarily costs everyone.

24. High Potential Testing

Copeland subjects all motor compressors to a high voltage test after final assembly. This is carried out according to EN 0530 or VDE 0530 part 1.

Since high voltage tests lead to premature ageing of the winding insulation, we do not recommend additional tests of that nature. They may also be carried out with new machines only. If it has to be done for any reason disconnect all electronic devices (e.g. motor protection module, fan speed control, etc.) prior to testing. The test voltage of 1000 V plus twice the nominal voltage is applied for 1 - 4 seconds between motor winding (each one of the phases) and the compressor shell: The maximum leak current limit is approximately 10 mA. Repeated tests have to be performed at lower voltages.

Caution: Do not carry out high voltage or insulation tests if the compressor housing is under vacuum. Compliant Scroll compressors are configured with the motor down and the pumping components at the top of the shell. As a result, the motor can be immersed in refrigerant to a greater extent than hermetic reciprocating compressors when liquid refrigerant is present in the shell. In this respect, the scroll is more like semi-hermetic (which have horizontal motors partially submerged in oil and refrigerant). When Compliant Scroll compressors are high potential tested with liquid refrigerant in the shell they can show higher levels of leakage current than compressors with the motor on top because of the higher electrical conductivity of liquid refrigerant than refrigerant vapour and oil. However, this they can show higher levels of leakage current than compressors with the motor on top because of the higher electrical conductivity of liquid refrigerant than refrigerant vapour and oil. However, this phenomenon can occur with any compressor when the motor is immersed in refrigerant. The levels of current leakage do not present any safety issue. To lower the current leakage reading the system should be operated for a brief period of time to redistribute the refrigerant to a more normal configuration and the system high potential tested again.

25. Installation

Four vibration absorber grommets are supplied with each compressor (see Fig. 13). They dampen the start-up surge of the compressor and prevent sounds and vibrations from being transmitted to the compressor base during operation to a large extent. The metal sleeve inside is intended as a guide to hold the grommet in place. It is not designed as a load-bearing member, and excessive torquing can crush the sleeve. Its inner diameter is approximately 8.5 mm to fit e.g. an M8 screw. The mounting torque should be 13 ± 1 Nm. It is critically important that the grommet is not compressed. A clearance space of approximately 2 mm between the bottom of the washer and the top of the grommet spacer is recommended (see Fig. 13)

For multiple or parallel operation please refer to guidelines C7.2.1/1101/E and the spares parts list.

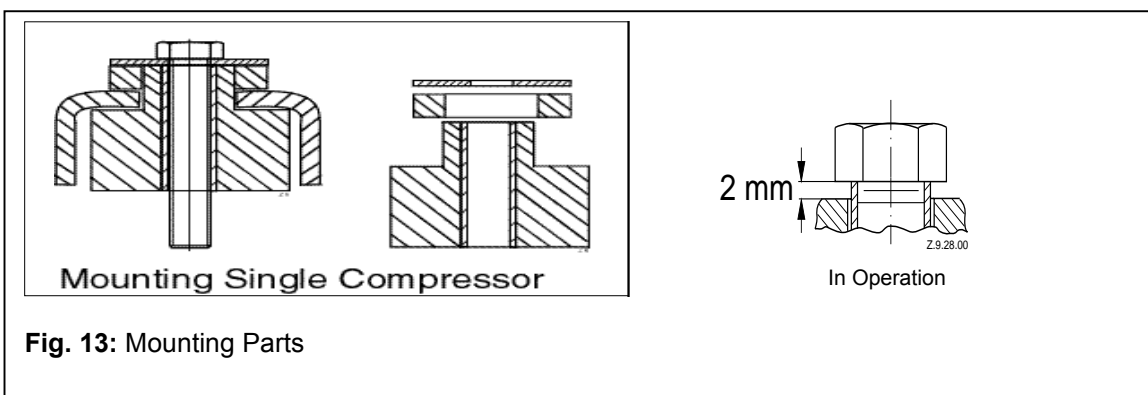



26. System Evacuation and Charging Procedure

Before the installation is put into commission, it has to be evacuated with a vacuum pump. Proper evacuation reduces residual moisture to 50 ppm. During the initial procedure, suction and discharge shut-off valves on the compressor remain closed. The installation of adequately sized access valves at the furthest point from the compressor in the suction and liquid line is advisable. Pressure must be measured using a vacuum pressure (Torr) gauge on the access valves and not on the vacuum pump; this serves to avoid incorrect measurements resulting from the pressure gradient along the connecting lines to the pump. These valves could also be used to measure the operating pressures to ensure there are no excessive pressure drops in the suction line and liquid line, which will also give an indication that the expansion device receives full bore liquid, ensuring the system performs at its most efficiently.

Evacuating the system only on the suction side of a Scroll compressor can occasionally result in a temporary no-start condition for the compressor. The reason for this is that the floating seal could axially seal with the scroll set, with the higher pressure on the floating seal. Consequently, until the pressures equalize, the floating seal and scroll set can be held tightly together.

The installation should be evacuated down to 0.3 mbar/ 0.22 Torr or lower. Subsequently, the factory holding charge of dry air in the compressor is released to the ambient. The shut-off valves are opened and the installation, including the compressor, are once more evacuated as described after the system has been re-charged with dry nitrogen.

Highest demands are placed on the leak proof design of the installation and on leak testing methods (please refer to EN378).

Rapid charging on the suction side of Scroll compressors can occasionally result in a temporary no-start condition for the compressor. The reason for this is that if the flanks of the spirals happen to be in a sealed position, rapid pressurization of the low side without opposing high side pressure can cause the spirals to seal axially. Consequently, until the pressures eventually equalize, the spirals can be held tightly together, preventing rotation. The best way to avoid this situation is to charge on both the high and low side simultaneously at a rate, which does not result in axial loading of the spirals. The maximum charging rate can be determined through simple tests.

27. Starting

During the very brief start-up, a short metallic sound is audible, resulting from initial contacting of the spirals and is normal.

Due to the design of the Compliant Scroll, the internal compression components always start unloaded even if system pressures are not balanced. In addition, since internal compressor pressures are always balanced at start-up, low-voltage starting characteristics are excellent for Compliant scroll compressors.

28. Rotation Direction

Scroll compressors, like several other types of compressors, will only compress in one rotational direction. Three phase compressors will rotate in either direction depending upon phasing of the power. The electronic protection unit (INT69SCY) will not let the compressor operate if the phasing of the wires are incorrect (see section 11). It is important to include notices and instructions in appropriate locations on the equipment to ensure proper rotation direction when the system is installed and operated.

Verification of proper rotation direction is made by observing that suction pressure drops and discharge pressure rises when the compressor is energised.

29. Shut-off Valves and Adaptors

The refrigeration scroll compressors are delivered with threads for Rotalock shut off valves. Braze pipework can also fit compressors with Rotalock connections using adaptors "A" and "B" in either straight or angled "C". (See Fig. 14 and spare parts list ZF/ZS and ZB).

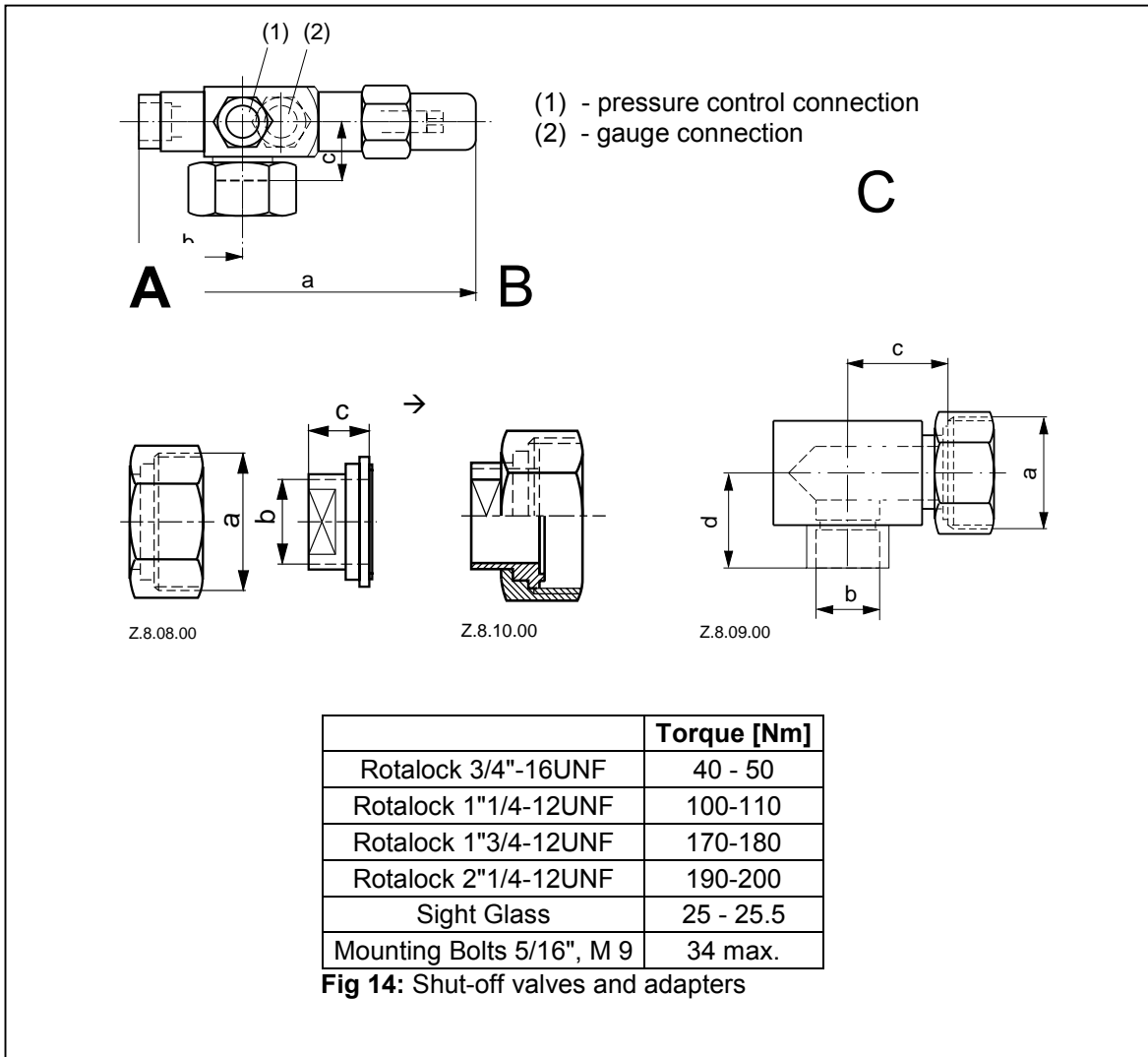



30. Unbrazing System Components

Caution! Before opening a system, it is important to remove all refrigerant from both the high and low side. If the refrigerant charge is removed from a scroll-equipped unit by bleeding the high side only, it is possible for the scrolls to seal preventing pressure equalisation through the compressor. This may leave the low side shell and suction line tubing pressurised. If a brazing torch is then applied to the low side while the low side shell and suction line contains pressure, the pressurised refrigerant and oil mixture could ignite when it escapes and contacts the brazing flame. To prevent this occurrence, it is important to check both the high and low side with manifold gauges before unbrazing. Instructions should be provided in appropriate product literature and assembly (line repair) areas. If compressor removal is required, the compressor should be cut out of system rather than unbrazed. See Fig. 14 (previous page) for proper compressor removal procedure.

31. Compressor Replacement

In the case of a motor burn, the majority of contaminated oil will be removed with the compressor. The rest of the oil is cleaned through use of suction and liquid line filter dryers. A 100% activated alumina suction filter drier is recommended but must be removed after 72 hours. It is highly recommended that the suction accumulator be replaced if the system contains one. This is because the accumulator oil return orifice or screen may be plugged with debris or may become plugged shortly after a compressor failure. This will result in starvation of oil to the replacement compressor and a second failure.

When a single compressor or tandem is exchanged in the field, a major portion of the oil may still be in the system. While this may not affect the reliability of the replacement compressor, the extra oil will add to rotor drag and increase power usage.

See Section for Rotalock valve, flange fittings, sight glass, and mounting bolt torque's values.

32. Pressure Equipment Directive

All the Refrigeration Scroll Compressors covered in this guideline conform to the European Pressure Equipment directive. The nameplate shows the PED marking CE 0062 with the refrigerant group and low side temperature.



33. Application Envelopes

Note: All Application Envelopes are for 25°C Suction Gas Return unless otherwise stated

R404A/R507

ZF24K4E to ZF48K4E

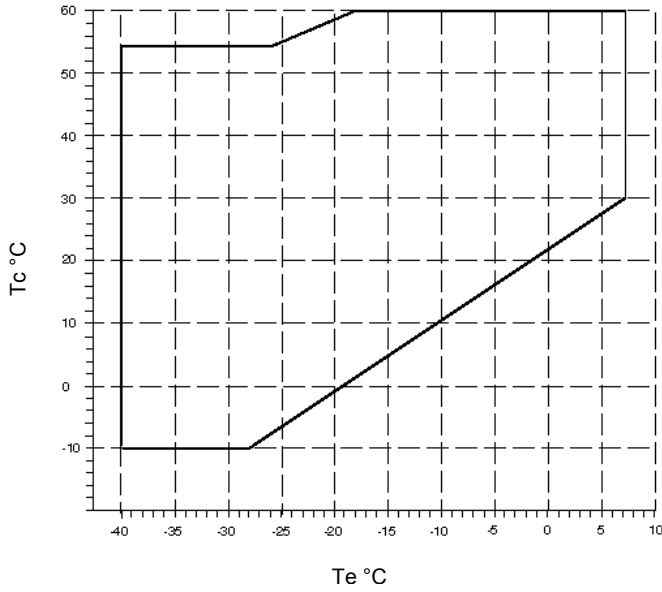

ZS56 to ZS11M3E

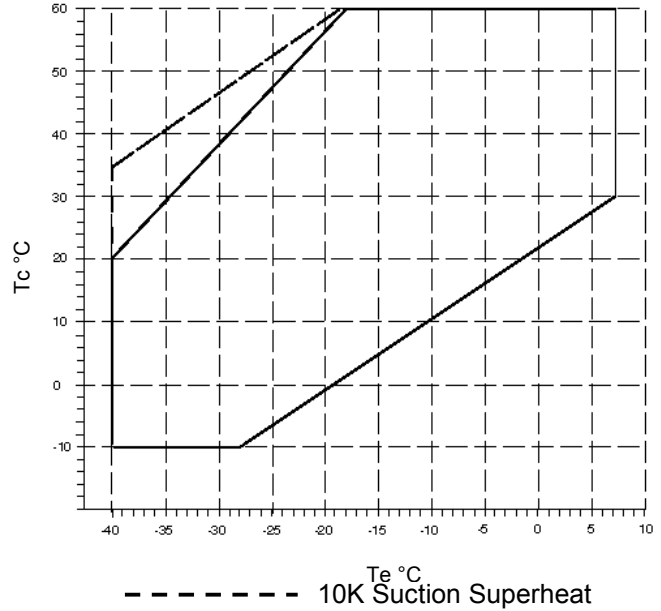

ZF24 to ZF48K4E
Economiser Operation

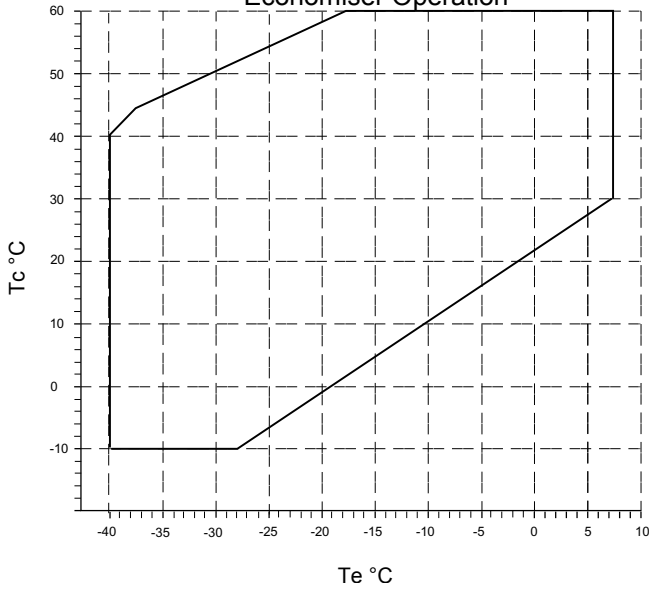

ZB56KCE to ZB11MCE

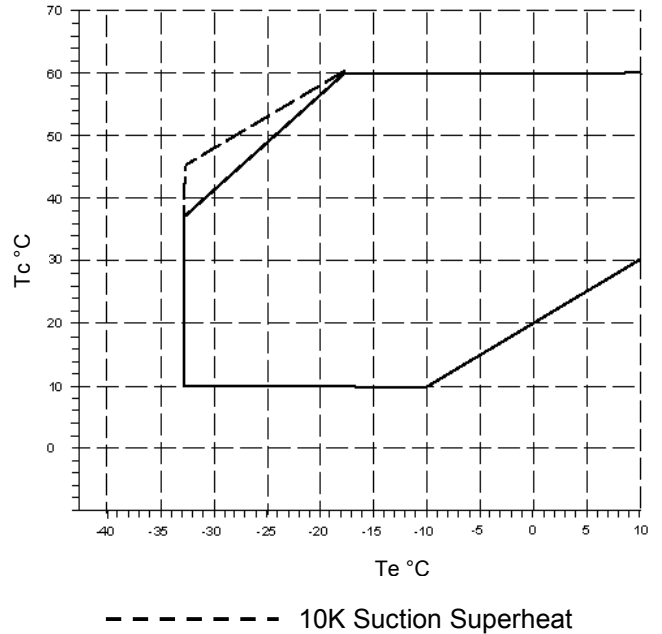

ZF24 to ZF48K4E

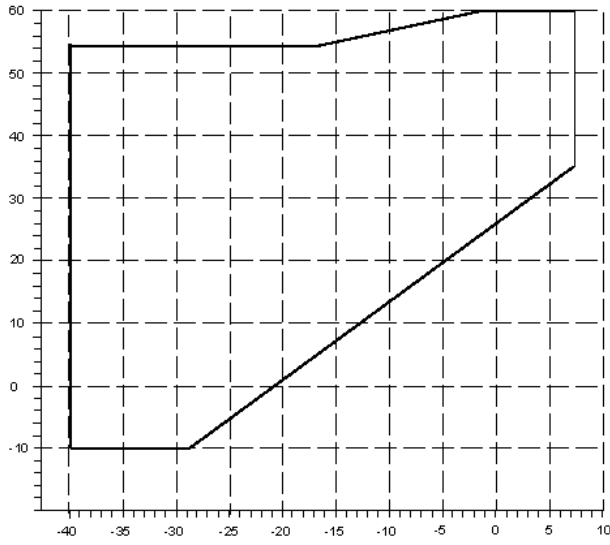

ZS56 to ZS11M3E

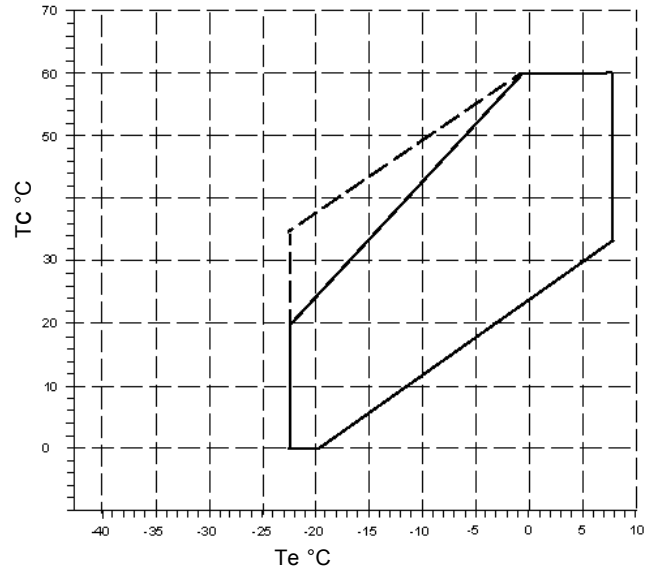

————— 10K Suction Superheat

ZF24K4E to ZF48K4E
Economiser Operation

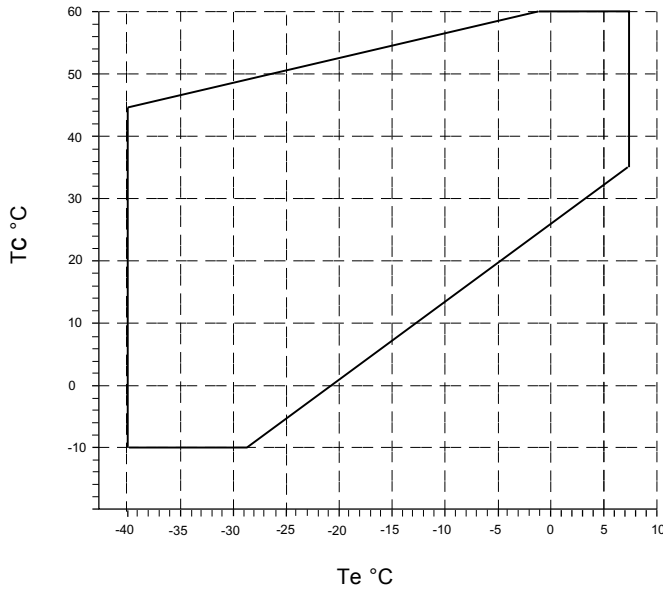

ZB56K4E to ZB11MCE

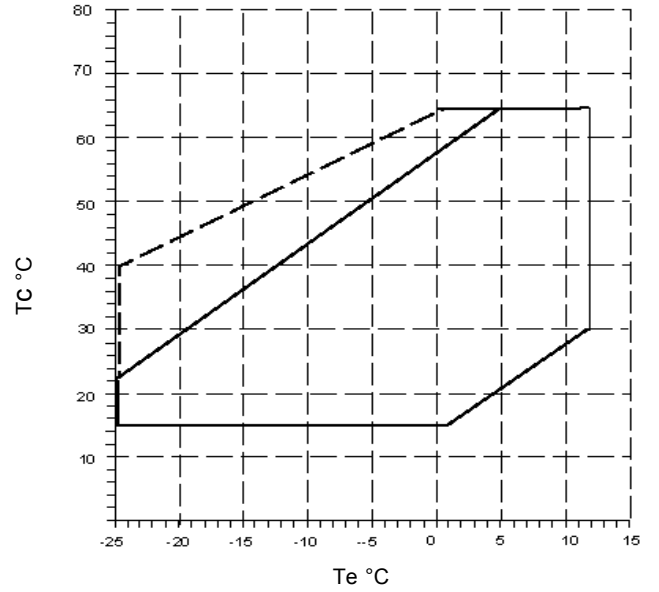

————— 10K Suction Superheat

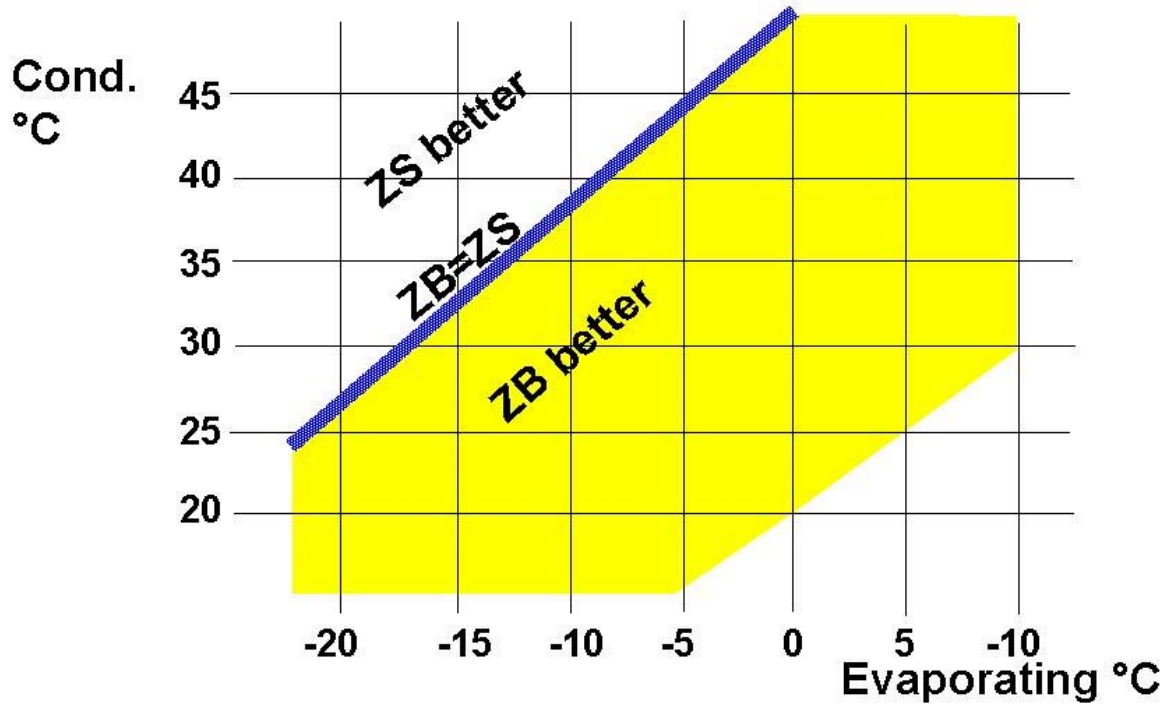
34. ZB/ZS Comparisons
R404A COP Comparison ZB/ZS

35. Motor Codes

Code	50 Hz	60 Hz	Connection
	Volt \pm 10%/ ~/Hz	Volt \pm 10%/ ~/Hz	
TWD	380-420/3/50 Hz	440-480/3/60Hz	Y
TW7	-	380/360Hz	Y
TWC	200/3/50 Hz	208-230/3/60Hz	Y
TWE	500/3/50 Hz	575/3/50Hz	Y
TWR	220-240/3/50 Hz	-	Y