

Features

- Fully hermetic
- Lower Pressure drop
- Corrosion free stainless steel body
- Crystal Indicator element for long lifetime and reliability
- Easily determination of moisture content
- Sensitive indicator with calibrated four colors. Conforms to requirement of most compressor manufacturers
- Large clear viewing area
- ODF extended tube configurations suitable for all commercial applications



MIA Moisture Indicator

Selection and Dimensions [mm]

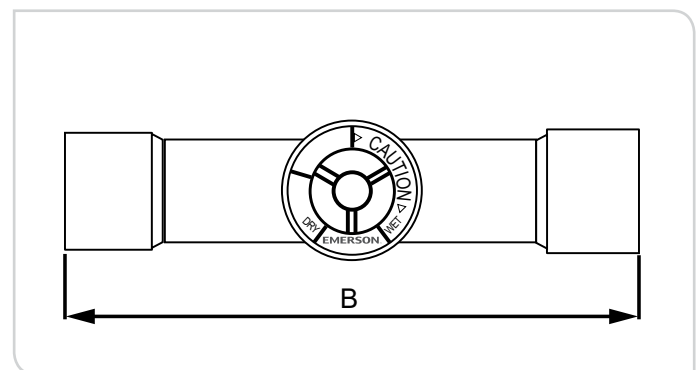
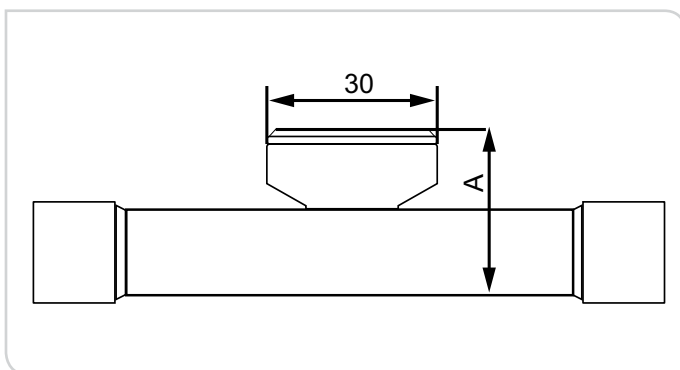

Type	Part no.	For tube outside diameter	Height A [mm]	Length B [mm]	Weight [g]
MIA 014-FLR	805895	1/4"	25.7	98.0	60
MIA 038-FLR	805896	3/8"	28.5	109.0	70
MIA 012-FLR	805897	1/2"	31.8	113.0	75
MIA 058-FLR	805898	5/8"	31.8	108.5	85
MIA 078-FLR	805899	7/8"	37.8	122.5	150
MIA 118-FLR	805900	1 1/8"	43.5	122.5	190

Type	Part no.	For tube outside diameter	Height A [mm]	Length B [mm]	Weight [g]
MIA M06-FLR	805901	6 mm	25.9	98.0	60
MIA M10-FLR	805894	10 mm	28.5	109.0	70
MIA M12-FLR	805902	12 mm	28.5	113.0	75
MIA M28-FLR	805903	28 mm	43.5	122.5	190
MIA M10S-FLR	805904	10 mm	28.7	119	75
MIA M12S-FLR	805905	12 mm	28.5	113	75

Technical Data

Maximum working pressure PS	35 bar
Test pressure PT	49.5 bar
Medium compatibility	R290, mineral-, alkyl benzene and ester lubricants
Connections	ODF extended copper tubes, solder connections only

Pressure drop	negligible
Operating temperature TS	-40...+100°C
External leakage (100% - production tested with Helium - Spectrometer)	5.0 x 10 ⁻⁶ mbar l/sec = 4.9 x 10 ⁻⁶ cc/sec
Standards	EN 12178

Determining the Moisture Content with the Color Code

Refrigerant	Liquid temperature °C	Moisture content in mg water per kg refrigerant (ppm)			
		Blue	Purple	Fuchsia	Rose
		Dry		Caution	Caution wet
R290	25	2	4	9	14
	38	5	8	18	29
	52	10	16	36	59

Note: In area “Caution” and “Caution wet” filter drier should be changed.



General Information

MIA...-FLR are sight glasses with moisture indicator.

The listed products are not in scope of ATEX product directive 94/9/EC as they do not incorporate an own source of ignition.

MIA...-FLR must be installed in an appropriate housing to protect them from mechanical damage or shock.

⚠ Safety Instructions

- **Read operating instructions thoroughly. Non-observance can result in device failure, system damage or personal injury.**
- **According to EN 13313 it is intended for use by persons having the appropriate knowledge and skill.**
- **R290 requires special handling and care due to its flammability. Sufficient ventilation is required during service of the system. Contact with rapidly expanding gases can cause frostbite and eye damage. Proper protective equipment (gloves, eye protection, etc.) has to be used.**
- **In a severely contaminated system, avoid breathing acid vapors and avoid contact with skin from contaminated refrigerant / lubricants. Failure to do so could result in injury.**
- **Ensure that the system is correctly labeled with applied refrigerant type and a warning for explosion risk.**
- **Do not release any refrigerant into the atmosphere!**
- **Do not exceed the specified maximum ratings for pressure and temperature.**
- **Before opening any system make sure pressure in system is brought to and remains at atmospheric pressure.**
- **Ensure that design, installation and operation are according to European and national standards/regulations.**

Mounting Location

- MIA...-FLR has to be installed only in the liquid line, otherwise the humidity reading can show wrong values.
- MIA...-FLR is bi-directional and may be installed in any position which allows visual access to the indicator window itself.
- The moisture indicator is normally located after the filter drier and before the expansion valve.

Installation

- Do not remove seal caps until ready for installation in order to minimize entering of moisture and dirt.

⚠ Avoid damaging the connections!

- The MIA...-FLR is fully hermetic and cannot be disassembled.

Recommended external pipe connection:

Nominal pipe connection	Outside diameter	
	Min. (mm)	Max. (mm)
1/4 "	6.30	6.38
3/8"	9.47	9.55
1/2"	12.62	12.73
5/8"	15.80	16.05
7/8"	22.15	22.25
1-1/8"	28.50	28.63
6 mm	5.95	6.05
10 mm	9.95	10.05
12 mm	11.96	12.05
28 mm	27.95	28.05

Brazing (Fig. 1)

- Perform and consider the brazing joint as per EN 14324.
 - Before and after brazing clean tubing and brazing joints.
 - To avoid oxidization, it is advised to purge the system with an inert gas such as nitrogen while brazing.
- Do not exceed the maximum temperature of 100°C.**

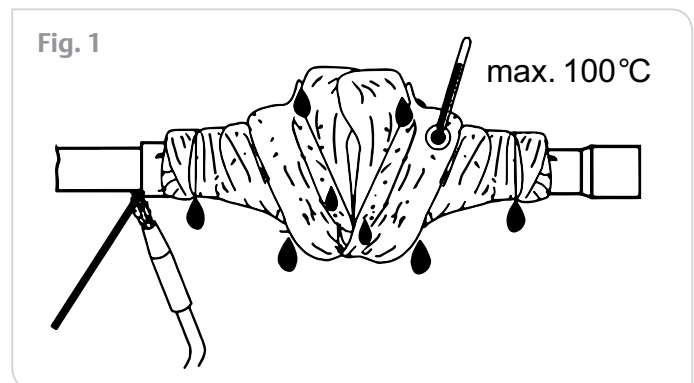

- To avoid overheating it is advised to make the join at one end and cool the indicator completely before repeating the procedure on the other end connection.
- Minimize vibrations in the piping lines by appropriate solutions.

Fig. 2

Refrigerant	Liquid temperature °C	ppm			
		Blue / Dry	Purple	Fuchsia / Caution	Rose / Caution wet
R290	25	2	4	9	14
	38	5	8	18	29
	52	10	16	36	59

Pressure Test

- After completion of installation, a pressure test must be carried out according to EN 378 for systems which must comply with European pressure equipment directive 97/23/EC.
- Max. system test pressure: 38.5 bar.

⚠ Warning

- **Failure to do so could result in loss of refrigerant and personal injury.**
- **The pressure test must be conducted by skilled persons with due respect regarding the danger related to pressure.**

Tightness Test

Conduct tightness test according to EN 378-2 with appropriate equipment and method to identify tightness of external joint. The allowable leakage rate must be according system manufacturer's specification.

Humidity Reading (Fig. 2)

- The humidity content in mg Water per kg refrigerant (ppm) can be identified by the color code in Fig. 2.
- A minimum period of 12 hours is recommended after installation before attempting to determine system moisture content.
- In case of indicator is showing **fuchsia** or **rose** color the change of the filter drier is required.

⚠ Service / Maintenance

- Defective MIA...-FLR must be replaced; they cannot be repaired.
- Disconnect electrical power before service.
- Before any debrazing ensure that the flammable refrigerant is pumped out of the system and the room around the system is well vented so no refrigerant left.

Technical Data of MIA... -FLR

- Max. allowable working pressure PS: 35 bar
- Test pressure PT: 49.5 bar
- Medium temperature TS: -40°C...+100 °C
- Released / compatible for: R290, mineral- and alkyl benzene, ester lubricants
- Standards: EN 12178

MIA types not listed in following table are not released for use with flammable refrigerants!

Type	Part no.
MIA 014-FLR	805895
MIA 038-FLR	805896
MIA 112-FLR	805897
MIA 058-FLR	805898
MIA 078-FLR	805899
MIA 118-FLR	805900
MIA M6-FLR	805901
MIA M10-FLR	805894
MIA M12-FLR	805902
MIA M28-FLR	805903
MIA M10S-FLR	805904
MIA M12S-FLR	805905